

TIP PROJECT: B-1303

CONTRACT: C201289

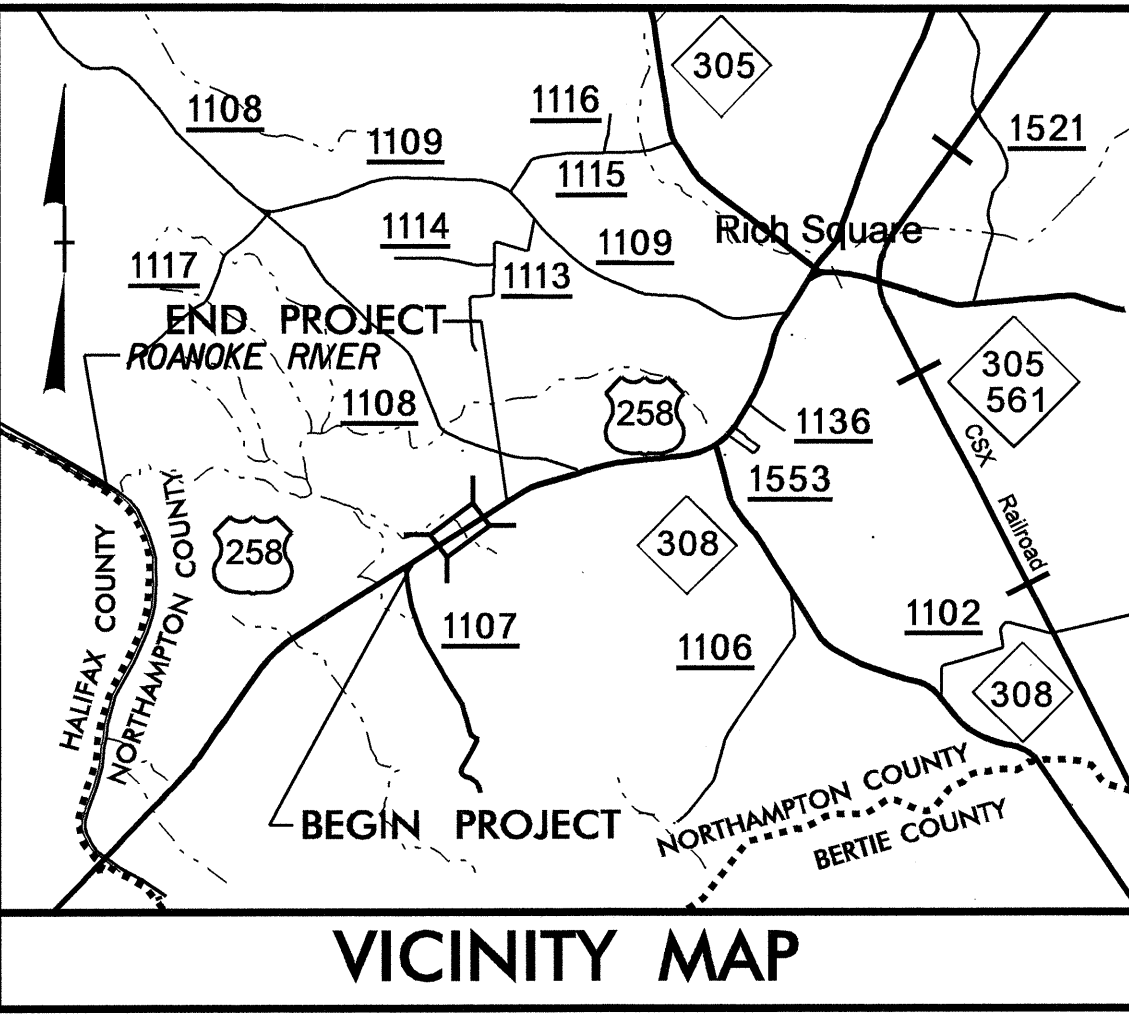

STATE OF NORTH CAROLINA
DIVISION OF HIGHWAYS

NORTHAMPTON COUNTY

**LOCATION: BRIDGE NO. 76 OVER ROANOKE RIVER OVERFLOW
ON US 258 SOUTHWEST OF RICH SQUARE**

**TYPE OF WORK: GRADING, PAVING, DRAINAGE, GUARDRAIL,
STRUCTURE, AND SIGNING**

STATE	STATE PROJECT REFERENCE NO.	SHEET NO.	TOTAL SHEETS
N.C.	B-1303		
STATE PROJ. NO.	F.A. PROJ. NO.	DESCRIPTION	
32589.1.1	BRSTP-258(5)	P.E.	
32589.2.2	BRSTP-258(5)	RW, UTIL	
32589.3.1	BRSTP-258(9)	CONST.	

STRUCTURE

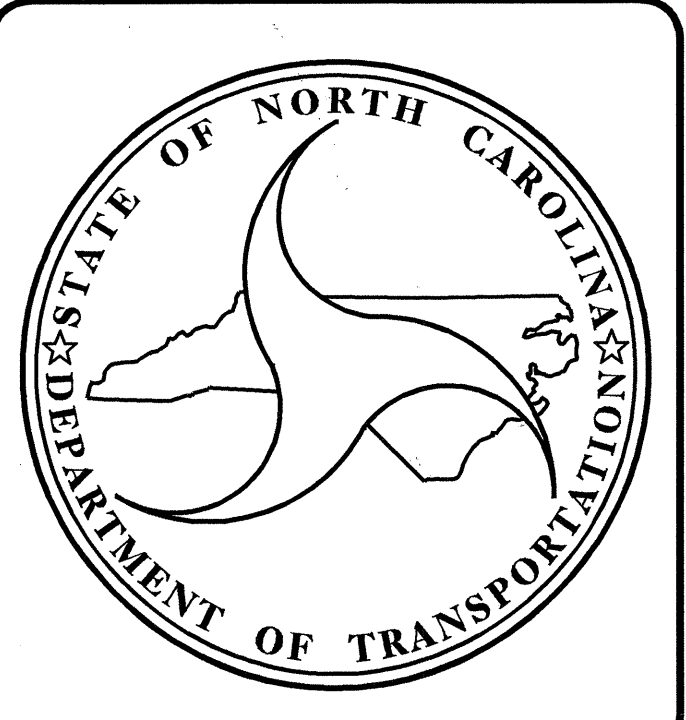
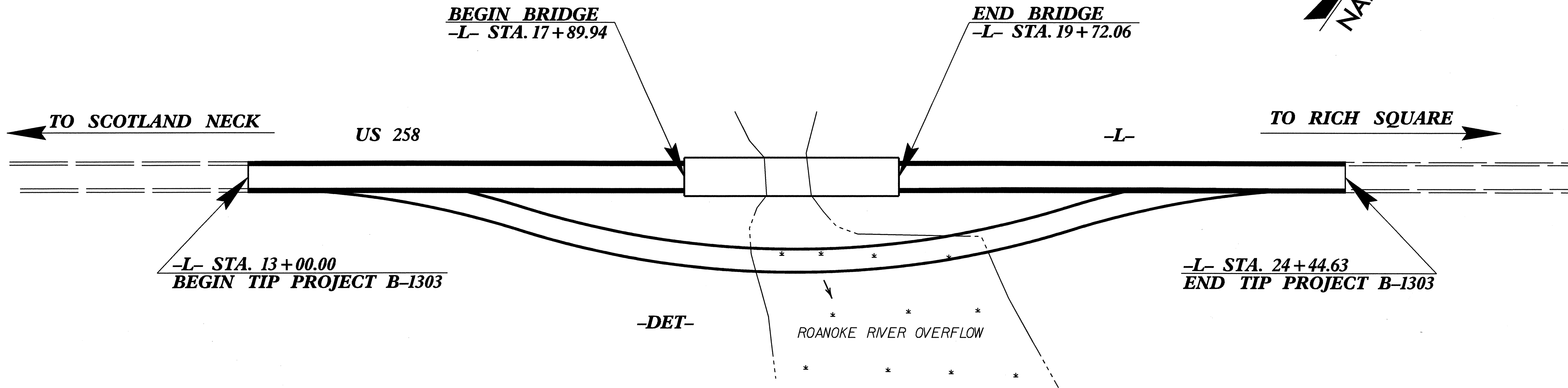

DESIGN DATA

ADT 2005 = 3260
ADT 2025 = 4490
DHV = 11 %
D = 55 %
T = 20 % *
V = 60 MPH
FUNC CLASS = RURAL
MINOR ARTERIAL

*(TTST 15% + DUAL 5%)

PROJECT LENGTH

LENGTH ROADWAY TIP PROJECT B-1303 = 0.183 MILES
LENGTH STRUCTURE TIP PROJECT B-1303 = 0.034 MILES
TOTAL LENGTH TIP PROJECT B-1303 = 0.217 MILES

Prepared In the Office of:
DIVISION OF HIGHWAYS

2002 STANDARD SPECIFICATIONS

LETTING DATE :
SEPTEMBER 20, 2005

B. S. COX, P. E.
PROJECT ENGINEER

D. E. PETREY, P. E.
PROJECT DESIGN ENGINEER

STRUCTURE DESIGN UNIT
1000 BIRCH RIDGE DR.
RALEIGH, N.C. 27610

NORTH CAROLINA
PROFESSIONAL
SEAL
14552
ENGINEER
GREGORY R. PERFETTI

Gregory R. Perfetti
8.8.05

DIVISION OF HIGHWAYS
STATE OF NORTH CAROLINA

P.E.
STATE DESIGN ENGINEER

DEPARTMENT OF TRANSPORTATION
FEDERAL HIGHWAY ADMINISTRATION

APPROVED
DIVISION ADMINISTRATOR

DATE