

SECTION THRU SLAB

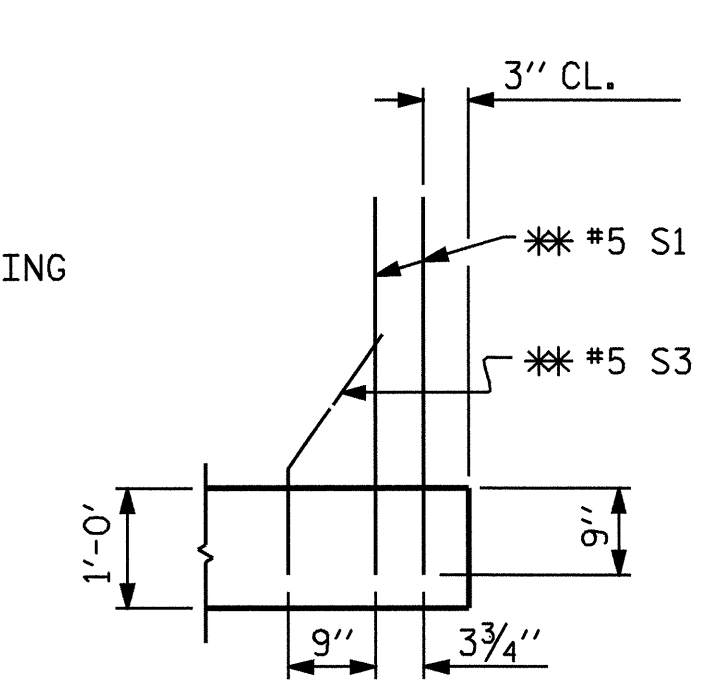

SECTION K-K  
\*\* ADHESIVELY ANCHORED

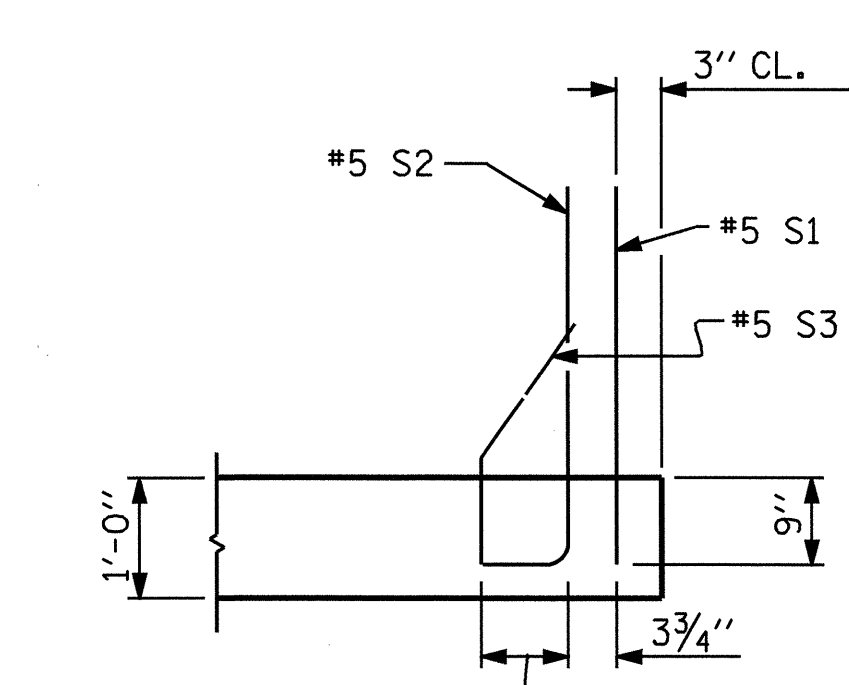

SECTION L-L

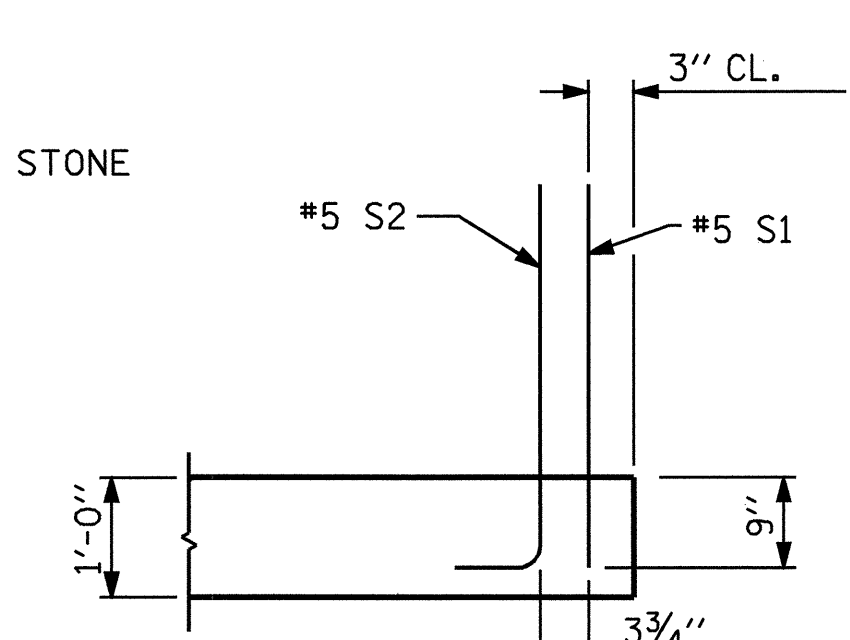

SECTION M-M

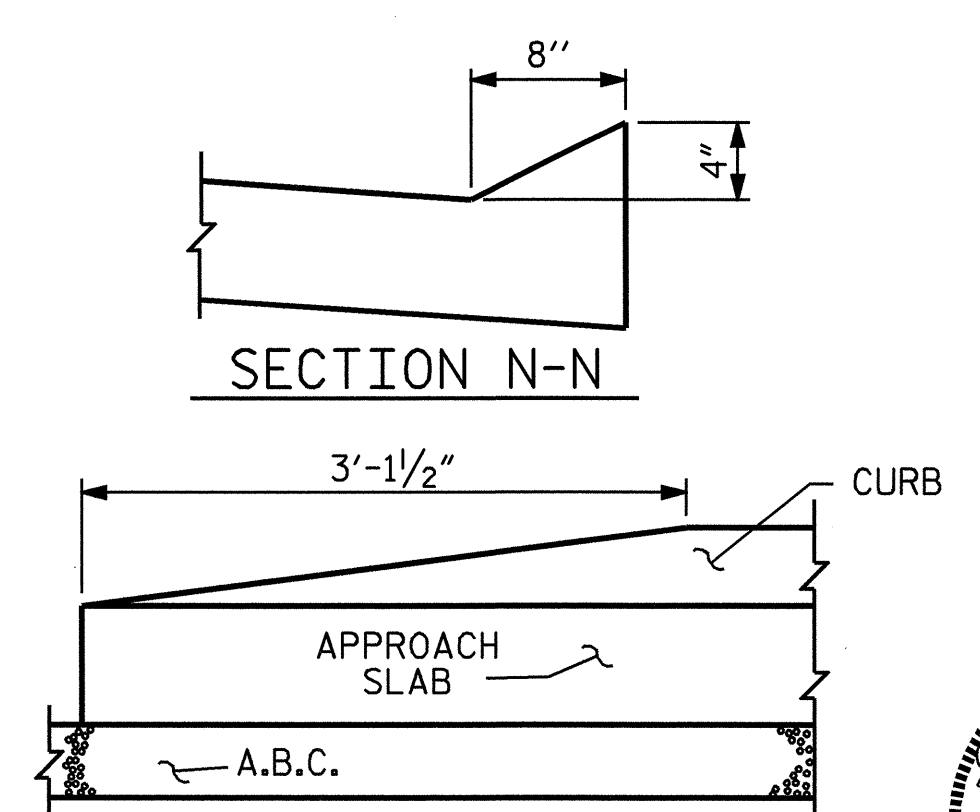

END OF CURB WITHOUT SHOULDER BERM GUTTER

NOTES

THE COST OF THE BARRIER RAIL ON THE APPROACH SLAB SHALL BE INCLUDED IN THE LUMP SUM CONTRACT PRICE BID FOR BRIDGE APPROACH SLABS.

APPROACH SLAB SHALL NOT BE CONSTRUCTED PRIOR TO COMPLETION OF THE BRIDGE DECK.

FOR REINFORCED BRIDGE APPROACH FILL INCLUDING FABRIC, IMPERMEABLE GEOMEMBRANE, 4" Ø DRAINAGE PIPE, #78M STONE, AND SELECT MATERIAL, SEE ROADWAY PLANS.

TEMPORARY DRAINAGE AND TEMPORARY BERM AND SLOPE DRAINS WILL BE PAID FOR UNDER THE LUMP SUM PRICE FOR BRIDGE APPROACH SLAB.

AREA BETWEEN THE WINGWALL AND APPROACH SLAB SHALL BE GRADED TO DRAIN THE WATER AWAY FROM THE FILL FACE OF THE BRIDGE AND SHALL BE PAVED. SEE ROADWAY PLANS.

THE 6" COMP. A.B.C. SHALL EXTEND 10'-0" BEYOND THE END OF THE APPROACH SLAB AND 1'-0" OUTSIDE OF EACH EDGE OF SLAB.

THE CONTRACTOR MAY USE 4" TYPE B-25.0B ASPHALT CONCRETE BASE COURSE IN LIEU OF 6" COMP. A.B.C. IF THIS OPTION IS USED, THE BASE COURSE SHALL EXTEND 1'-0" BEYOND THE END OF THE APPROACH SLAB AND THE WIDTH SHALL BE THE SAME AS THAT OF THE APPROACH SLAB.

THE CONTRACTOR MAY USE 5" CLASS "A" CONCRETE BASE IN LIEU OF 6" COMP. A.B.C. IF THIS OPTION IS USED, THE CONCRETE BASE SHALL EXTEND 1'-0" BEYOND THE END OF THE APPROACH SLAB AND THE WIDTH SHALL BE THE SAME AS THAT OF THE APPROACH SLAB. THE CONCRETE SHALL BE FINISHED TO A SMOOTH SURFACE AND A LAYER OF 30 LB ROOFING FELT SHALL BE PLACED BETWEEN THE CONCRETE BASE AND THE APPROACH SLAB TO PREVENT BOND. THE APPROACH SLAB SHALL NOT BE CAST UNTIL THE CONCRETE BASE HAS REACHED AN AGE OF THREE CURING DAYS.

FOR EVAZOTE JOINT SEALS, SEE SPECIAL PROVISIONS.

THE NOMINAL UNCOMPRESSED SEAL WIDTH OF THE EVAZOTE JOINT SEAL SHALL BE 3 7/16".

FOR ELASTOMERIC CONCRETE, SEE SPECIAL PROVISIONS.

BILL OF MATERIAL  
FOR ONE APPROACH SLAB  
(2 REQ'D)

BAR	NO.	SIZE	TYPE	LENGTH	WEIGHT
*A1	49	#5	STR	44'-4"	2266
A2	98	#4	STR	23'-1"	1511
*B1	89	#6	STR	24'-3"	3242
B2	89	#8	STR	24'-8"	5862
*B3	14	#5	STR	11'-8"	170
*B4	2	#5	3	6'-5"	13
*S1	56	#5	STR	3'-3"	190
*S2	40	#5	1	4'-1"	170
*S3	20	#5	2	2'-3"	47
REINFORCING STEEL				LBS.	7373
*EPOXY COATED REINFORCING STEEL				LBS.	6098
CLASS AA CONCRETE BREAKDOWN					
POUR 1 SLAB AND CURB				C. Y.	42.2
POUR 2 RAIL				C. Y.	2.1
CLASS AA CONCRETE				C. Y.	44.3

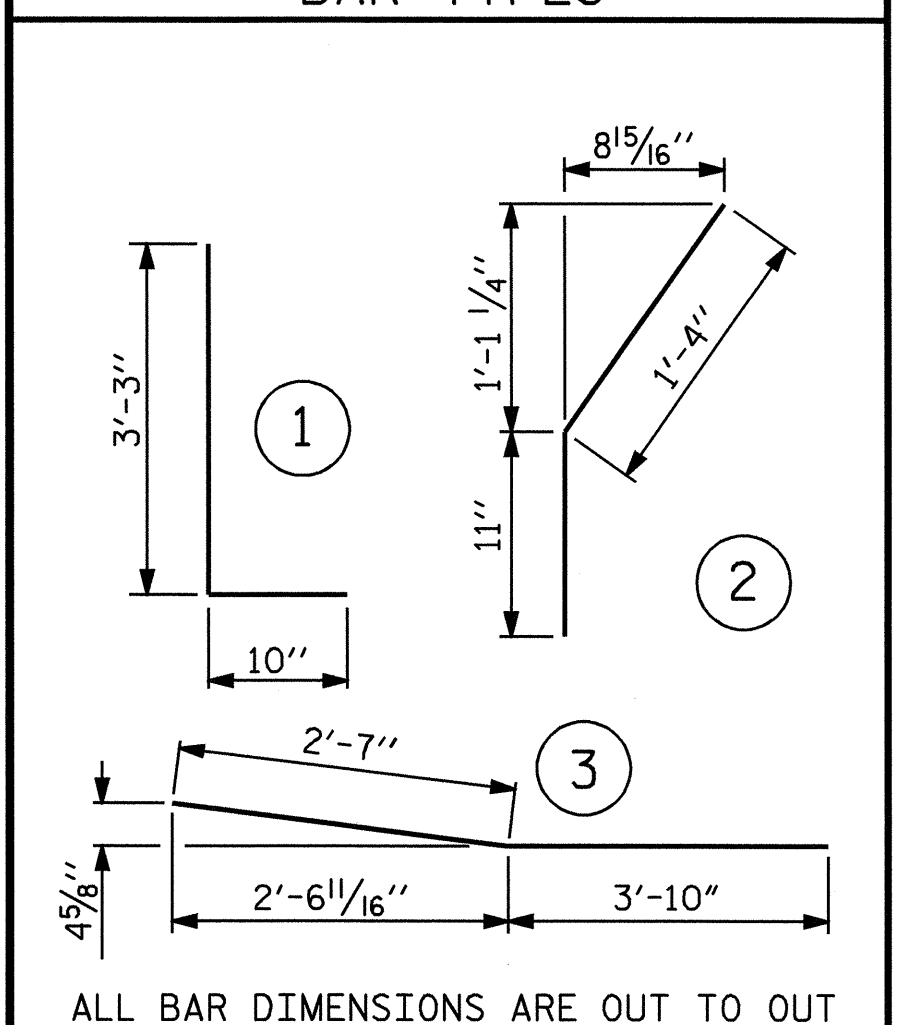

PROJECT NO. B-1303  
NORTHAMPTON COUNTY  
STATION: 18+81.00 -L-

SHEET 1 OF 3

STATE OF NORTH CAROLINA  
DEPARTMENT OF TRANSPORTATION  
RALEIGH  
STANDARD  
BRIDGE APPROACH SLAB  
FOR FLEXIBLE PAVEMENT  
WITH BARRIER RAIL

REVISIONS						SHEET NO.
NO.	BY:	DATE:	NO.	BY:	DATE:	S-18
1			3			TOTAL SHEETS
2			4			20

ASSEMBLED BY: R. G. EMERSON DATE: 01/05  
CHECKED BY: B. N. GRADY DATE: 01/05  
DRAWN BY: LES 8/01 REV. 5/7/03R RWW/JTE  
CHECKED BY: RDR 8/01