

NOTES

REINFORCING STEEL IN CAP MAY BE SHIFTED AS NECESSARY TO CLEAR ANCHOR BOLTS.
 FOR REINFORCING STEEL IN PIPE PILES, SEE "18" STEEL PIPE PILE" SHEET.

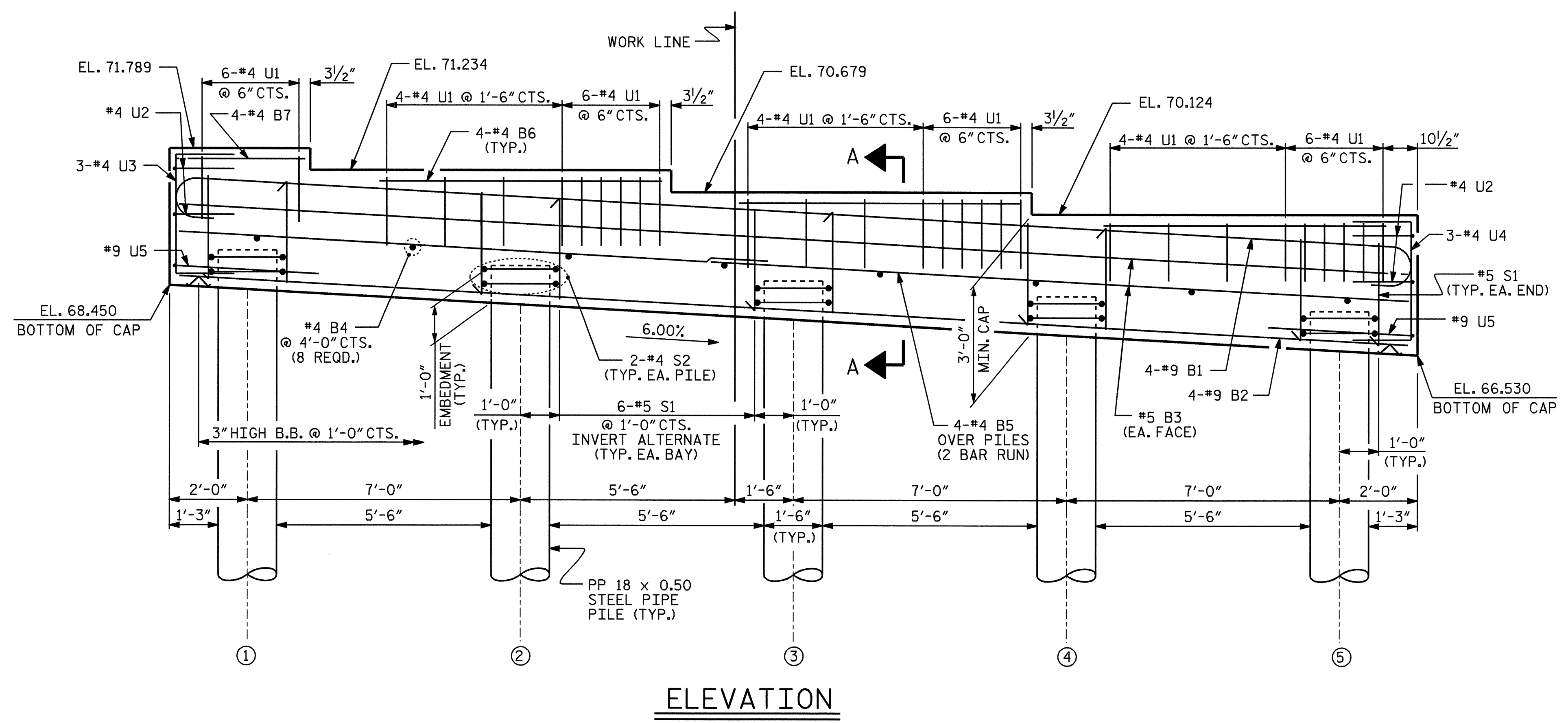
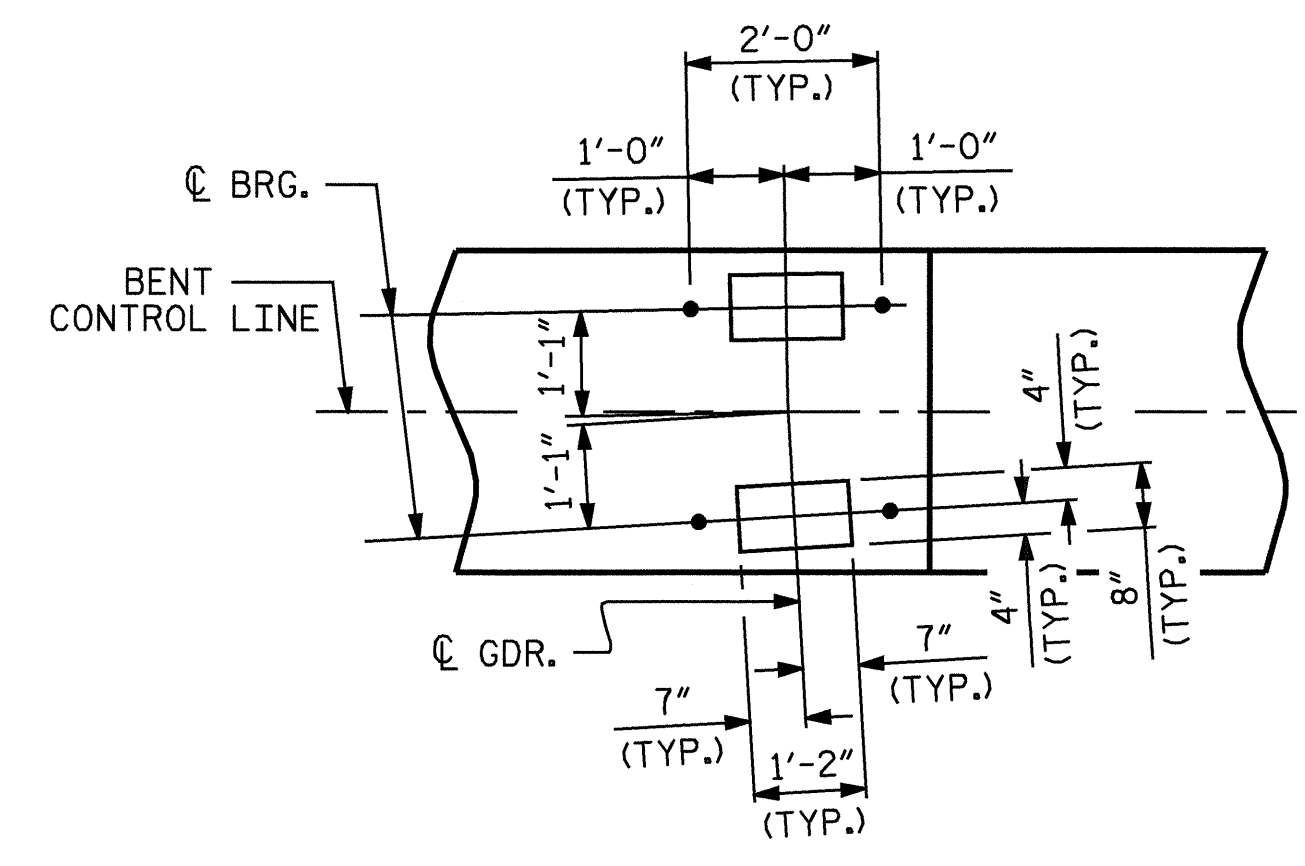
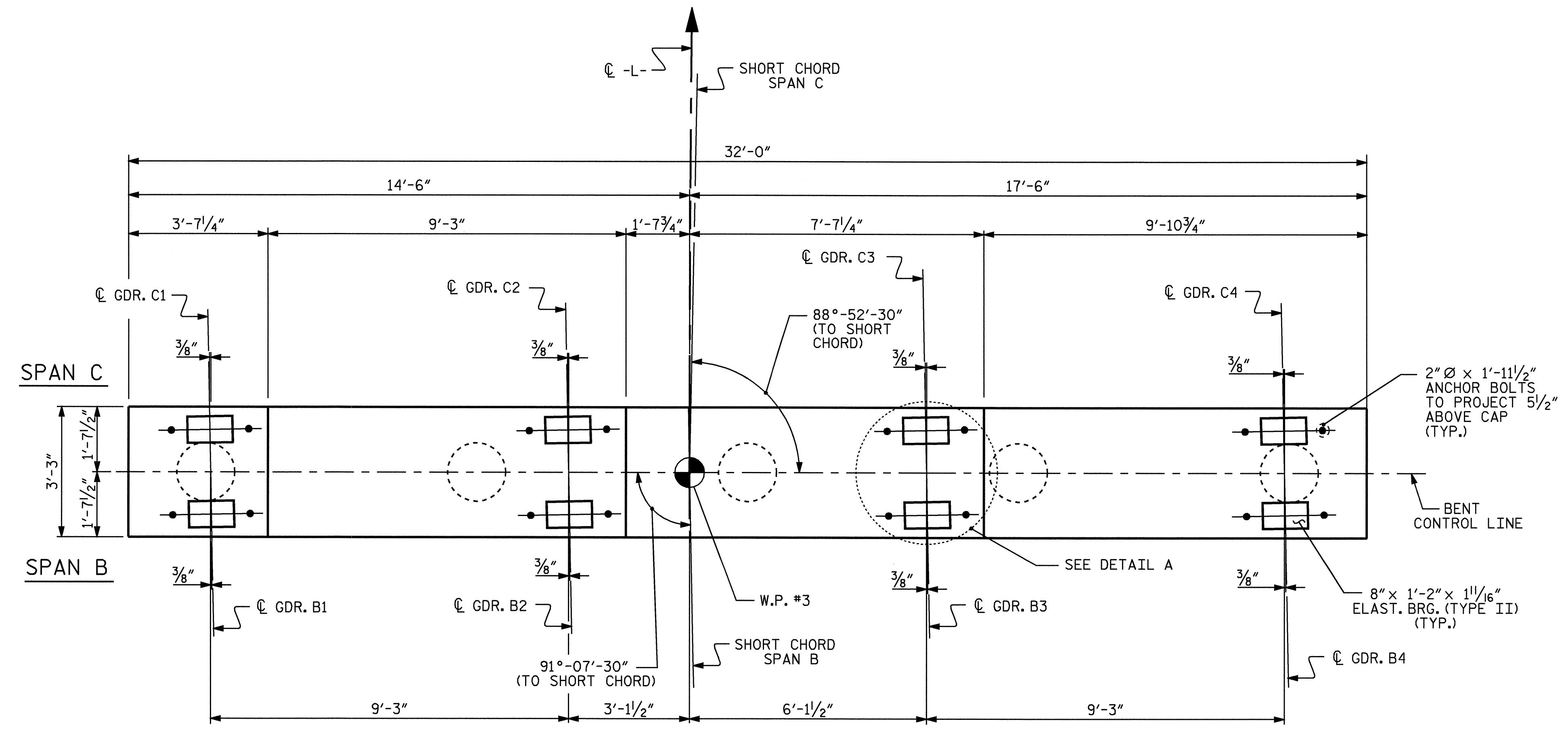

SPLICE LENGTH CHART

BAR	SIZE	SPLICE LENGTH
B5	#4	2'-5"

TOP OF PILE ELEVATIONS

1	69.375
2	68.995
3	68.535
4	68.115
5	67.695

PROJECT NO. B-3467
HALIFAX COUNTY
 STATION: 20+75.00 -L-

SHEET 1 OF 2

STATE OF NORTH CAROLINA
 DEPARTMENT OF TRANSPORTATION
 RALEIGH

**SUBSTRUCTURE
 BENT 2**

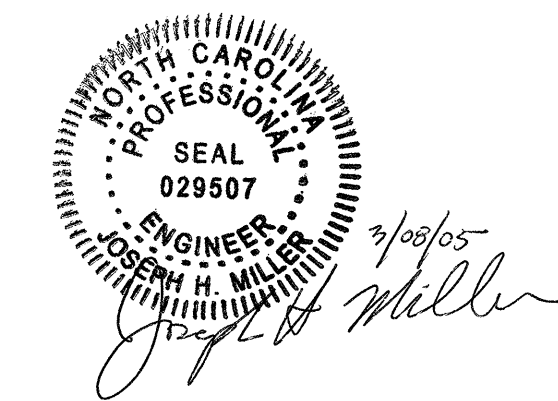

REVISIONS

NO.	BY:	DATE:	NO.	BY:	DATE:
1			3		
2			4		

SHEET NO. S-21
 TOTAL SHEETS 60

DRAWN BY: B.N.BARODAWALA DATE: 10-7-03
 CHECKED BY: J.H.MILLER DATE: 1-10-05

08-MAR-2005 14:19
 W:\Squad1\B3467.v8\str1\bbarodawala\B3467.sd.B*01.dgn
 Isuttron