

PLAN OF SPANS

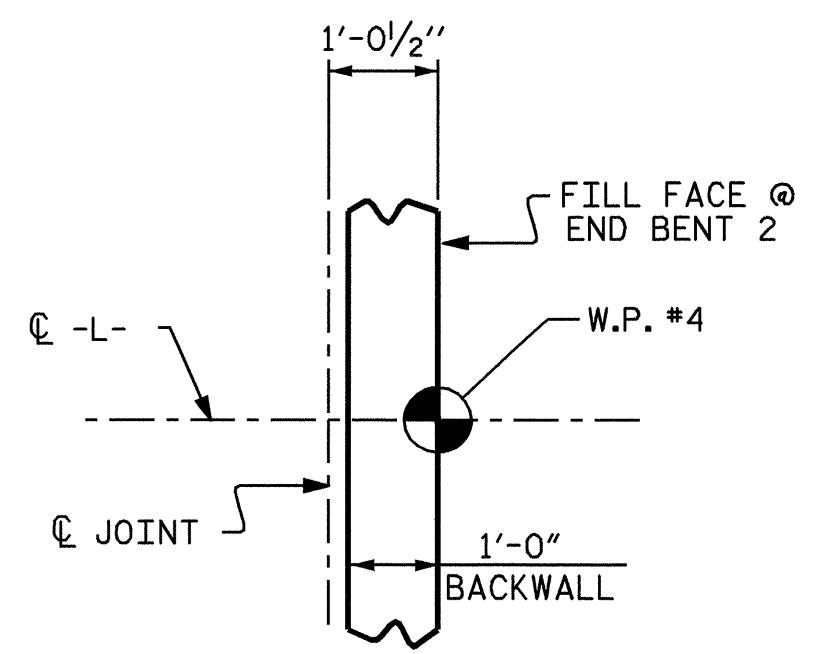

DETAIL B

PROJECT NO. B-3467
HALIFAX COUNTY
 STATION: 31+50.00 -L-

SHEET 2 OF 2

STATE OF NORTH CAROLINA
 DEPARTMENT OF TRANSPORTATION
 RALEIGH

SUPERSTRUCTURE
 PLAN OF SPANS



REVISIONS						SHEET NO.
NO.	BY:	DATE:	NO.	BY:	DATE:	S-39
1			3			TOTAL SHEETS
2			4			60

DRAWN BY: J.L. WALTON DATE: 4/22/03
 CHECKED BY: B.N. BARODAWALA DATE: 6/5/03

08-MAR-2005 14:19
 W:\Squad\B3467_v8\str2\jwalton\B3467_sd.S*.02.dgn
 lsutton