

NOTES

PROVIDE 32mm HIGH BEAM BOLSTERS UPPER AT 1.2m CTS. ATOP THE METAL STAY-IN-PLACE FORMS TO SUPPORT THE BOTTOM MAT OF "A" BARS. WHEN USING REMOVABLE FORMS, PROVIDE CONTINUOUS HIGH CHAIRS FOR METAL DECK (C.H.C.M.) @ 1.2m CTS. WITH A HEIGHT TO SUPPORT THE BOTTOM MAT OF "A" BARS A CLEAR DISTANCE OF 65mm ABOVE THE TOP OF THE REMOVABLE FORM.

BARRIER RAIL IN A CONTINUOUS UNIT SHALL NOT BE CAST UNTIL ALL SLAB CONCRETE IN THAT UNIT HAS BEEN CAST AND HAS REACHED A MINIMUM COMPRESSIVE STRENGTH OF 20.7 MPa.

FOR MODULAR EXPANSION JOINT SEALS, SEE SPECIAL PROVISIONS.

THE MODULAR EXPANSION JOINT SEAL AT END BENT #1 SHALL BE CAPABLE OF HANDLING A TOTAL THERMAL MOVEMENT, MEASURED PARALLEL TO THE CENTERLINE OF ROADWAY, OF 85mm (42mm EXPANSION AND 43mm CONTRACTION FROM A MIDPOINT TEMPERATURE OF 16 DEGREES C), AND END BENT #2 SHALL BE CAPABLE OF HANDLING A TOTAL THERMAL MOVEMENT, MEASURED PARALLEL TO THE CENTERLINE OF ROADWAY, OF 93mm (46mm EXPANSION AND 47mm CONTRACTION FROM A MIDPOINT TEMPERATURE OF 16 DEGREES C).

SET TOP OF MODULAR EXPANSION JOINT SEAL DEVICE A MINIMUM OF 3mm AND A MAXIMUM OF 6mm BELOW THE TOP OF SLAB.

SPECIAL SNOWPLOW PROTECTION IS REQUIRED. SEE SPECIAL PROVISION FOR MODULAR EXPANSION JOINT SEALS.

METAL STAY-IN-PLACE FORMS SHALL NOT BE WELDED TO GIRDER FLANGES IN THE ZONES REQUIRING CHARTY V-NOTCH TEST. SEE STRUCTURAL STEEL DETAIL SHEETS.

PREVIOUSLY CAST CONCRETE IN A CONTINUOUS UNIT SHALL HAVE ATTAINED A MINIMUM COMPRESSIVE STRENGTH OF 20.7 MPa BEFORE ADDITIONAL CONCRETE IS CAST IN THE UNIT.

STRUCTURAL STEEL ERECTION IN A CONTINUOUS UNIT SHALL BE COMPLETE BEFORE FALSEWORK OR FORMS ARE PLACED ON THE UNIT.

THE CONTRACTOR MAY, WHEN NECESSARY, PROPOSE A SCHEME FOR AVOIDING INTERFERENCE BETWEEN METAL STAY-IN-PLACE FORM SUPPORTS OR FORMS AND GIRDER STIFFENERS OR CONNECTOR PLATES. THE PROPOSAL SHALL BE INDICATED, AS APPROPRIATE, ON EITHER THE STEEL WORKING DRAWINGS OR THE METAL STAY-IN-PLACE FORM WORKING DRAWINGS.

THE CONTRACTOR SHALL ADJUST THE GIRDER BUILDUPS AS NECESSARY TO INCORPORATE A MAXIMUM PERMISSIBLE VARIATION IN POT BEARING DEPTH OF 13mm, SEE SPECIAL PROVISION FOR POT BEARINGS.

THE "B" BARS IN THE DECK SLAB MAY BE CUT AS DIRECTED BY THE ENGINEER TO CLEAR THE MODULAR JOINT SUPPORT BOXES.

FOR BARS INDICATED AND NO MARKS SHOWN, SEE PLAN OF SPANS.

REINFORCING STEEL AND STIRRUPS MAY BE SHIFTED SLIGHTLY AS NECESSARY TO CLEAR DRAIN PIPES.

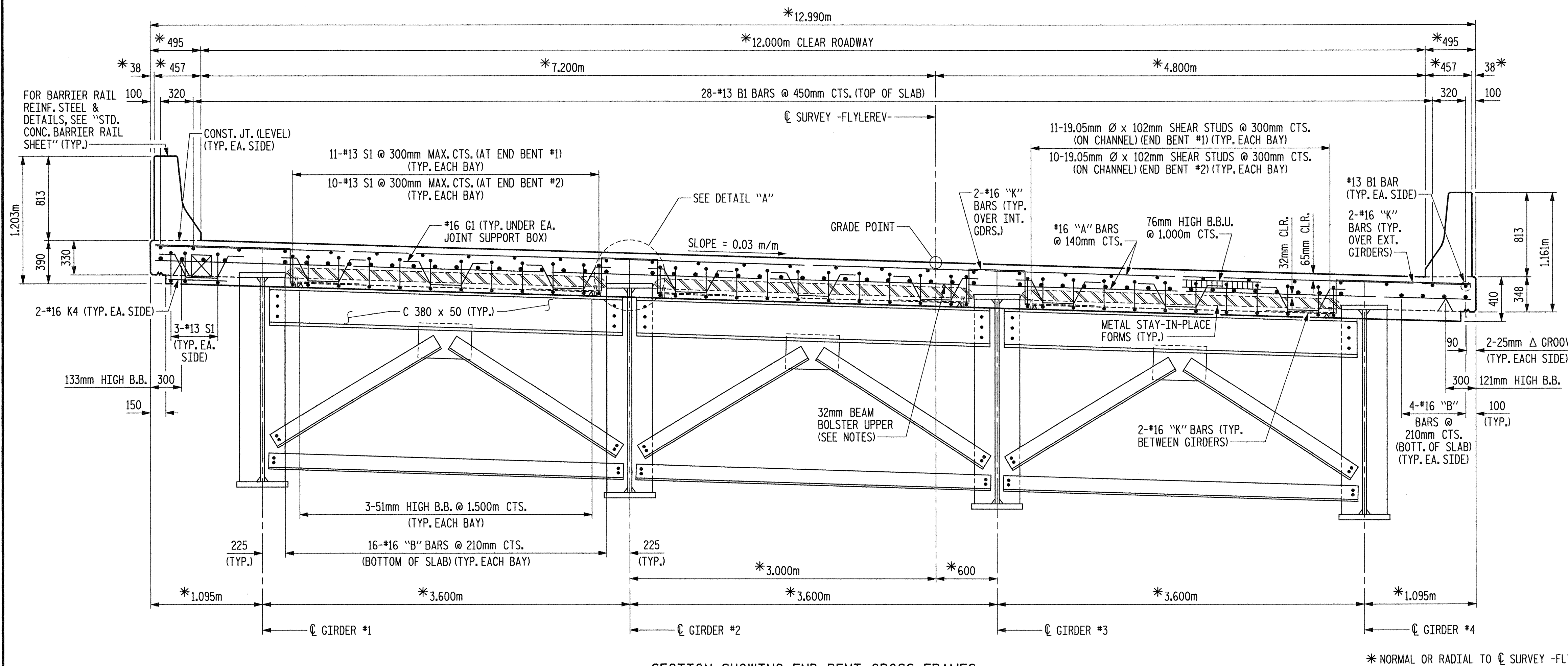

SECTION SHOWING END BENT CROSS FRAMES
FOR DETAILS, SEE "DROPWALL DETAILS AT END BENT CROSSFRAME" ON SHEET 2 OF 2.

TYPICAL SECTION

152mm Ø PVC PIPE DRAINS FROM STA. 24+28.300 -FLYLEREV- TO STA. 24+82.300 -FLYLEREV- ARE TO DRAIN INTO A CLOSED BRIDGE DRAINAGE SYSTEM. FOR DETAILS, SEE "STRUCTURE DRAINAGE SYSTEM DETAILS".

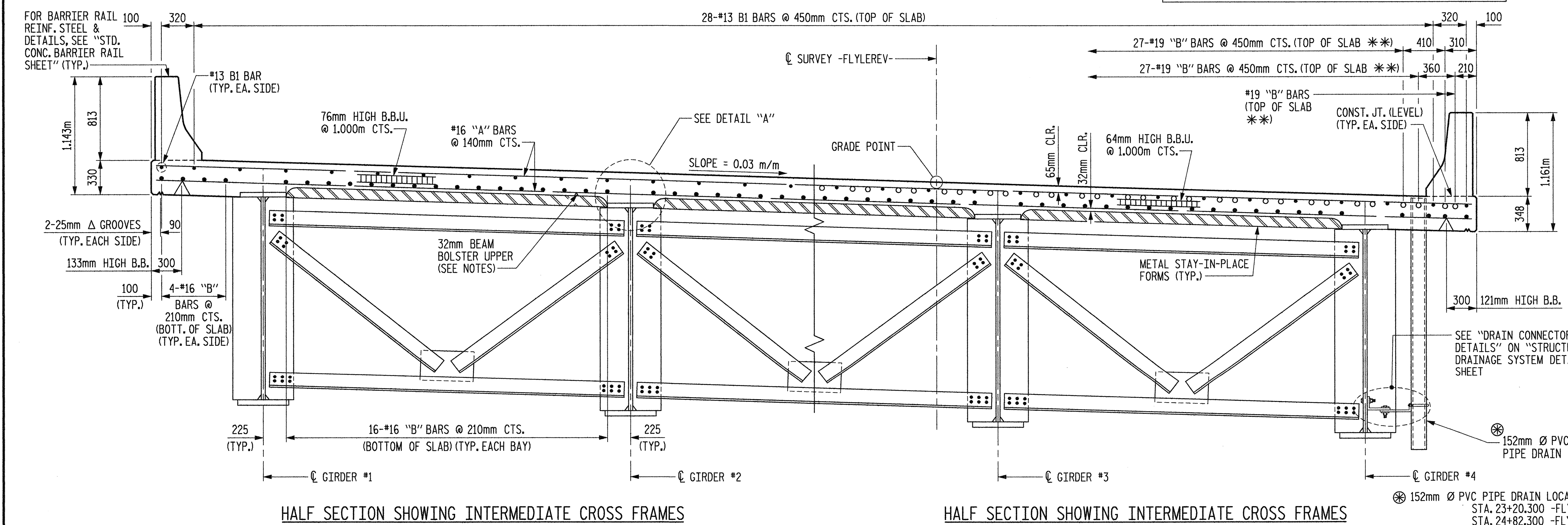

HALF SECTION SHOWING INTERMEDIATE CROSS FRAMES

HALF SECTION SHOWING INTERMEDIATE CROSS FRAMES AT INTERIOR BENTS #2, #3 AND #4

TYPICAL SECTION

FOR DIMENSIONS NOT SHOWN, SEE TYPICAL SECTION ABOVE

** SEE SUPERSTRUCTURE "B" BAR LAYOUT FOR LOCATIONS.

NOTE: FOR INTERMEDIATE CROSS FRAMES AT BENT #1, SEE "STRUCTURAL STEEL DETAILS" SHEET 2 OF 4.

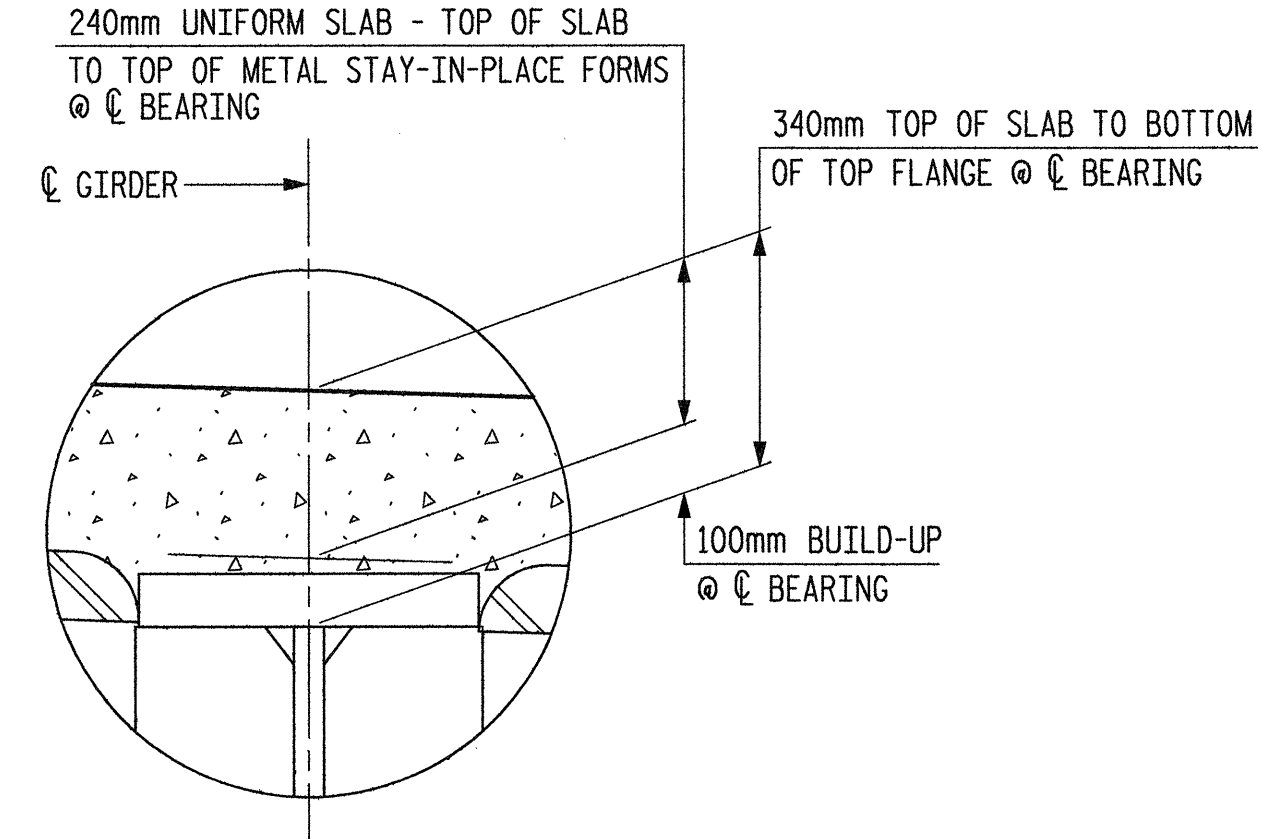

DETAIL "A"

PROJECT NO. R-252AA
WAKE-JOHNSTON COUNTY
STATION: 28+31.359 -I1Y1-

SHEET 1 OF 2

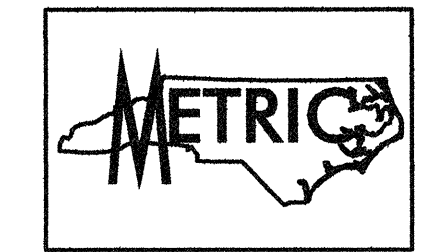

STATE OF NORTH CAROLINA
DEPARTMENT OF TRANSPORTATION
RALEIGH

SUPERSTRUCTURE
TYPICAL SECTION AND DETAILS

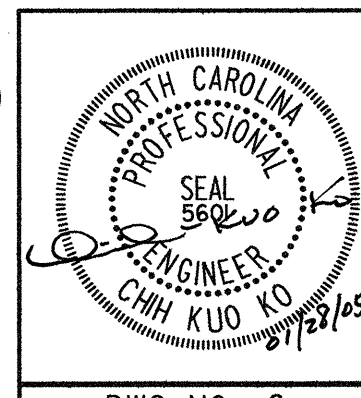

Plans prepared by:
KO & ASSOCIATES, P.C.
Consulting Engineers
101 SCHAUB DR. SUITE #202
RALEIGH, N.C. 27606
For Division of Highways

REVISIONS						SHEET NO.
NO.	BY:	DATE:	NO.	BY:	DATE:	TOTAL SHEETS
1			3			5-89
2			4			429

DWG. NO. 6

FILE NAME: r:\252aa\sta_s1.dwg
DRAWN BY: B.E. LANNING
CHECKED BY: J.C. KO / A.K. ORR
DATE: JAN. 2005
DATE: JAN. 2005