

NOTES:

PROVIDE 32 mm BEAM BOLSTERS UPPER @ 1.200 m CTS. ATOP THE METAL STAY-IN-PLACE FORMS TO SUPPORT THE BOTTOM MAT OF "A" BARS. WHEN USING REMOVABLE FORMS, PROVIDE CONTINUOUS HIGH CHAIRS FOR METAL DECK (C.H.C.M) @ 1.200 m CTS. WITH A HEIGHT TO SUPPORT THE BOTTOM MAT OF "A" BARS A CLEAR DISTANCE OF 65 mm ABOVE THE TOP OF THE REMOVABLE FORM.

METAL STAY-IN-PLACE FORMS SHALL NOT BE WELDED TO BEAM OR GIRDER FLANGES IN THE ZONES REQUIRING CHARPY V-NOTCH TEST. SEE STRUCTURAL STEEL DETAILS SHEETS.

PREVIOUSLY CAST CONCRETE IN A CONTINUOUS UNIT SHALL HAVE ATTAINED A MINIMUM COMPRESSIVE STRENGTH OF 20.7 MPa BEFORE ADDITIONAL CONCRETE IS CAST IN THE UNIT.

STRUCTURAL STEEL ERECTION IN A CONTINUOUS UNIT SHALL BE COMPLETE BEFORE FALSEWORK OR FORMS ARE PLACED ON THE UNIT.

THE CONTRACTOR MAY, WHEN NECESSARY, PROPOSE A SCHEME FOR AVOIDING INTERFERENCE BETWEEN METAL STAY-IN-PLACE FORM SUPPORTS OR FORMS AND BEAM/GIRDER STIFFENER OR CONNECTOR PLATES. THE PROPOSAL SHALL BE INDICATED, AS APPROPRIATE, ON EITHER THE STEEL WORKING DRAWINGS OR THE METAL STAY-IN-PLACE FORM WORKING DRAWINGS.

THE CONTRACTOR SHALL ADJUST THE GIRDER BUILDBUPS AS NECESSARY TO INCORPORATE A MAXIMUM PERMISSIBLE VARIATION IN POT BEARING DEPTH OF 13mm, SEE SPECIAL PROVISIONS FOR POT BEARINGS.

FOR CONSTRUCTION SEQUENCE, SEE "INTEGRAL END BENT GIRDER DETAILS" SHEET, SHEET 5 OF 5.

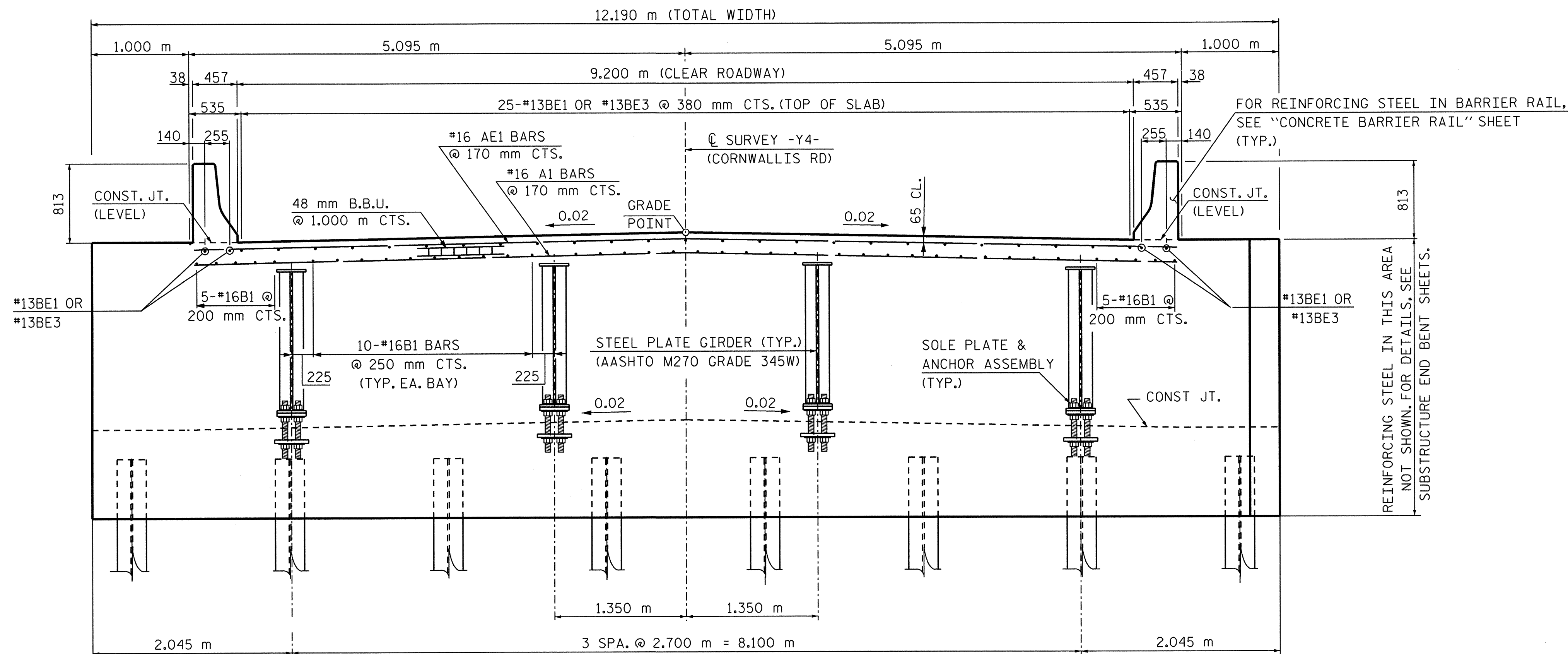

TYPICAL SECTION @ INTEGRAL END BENT

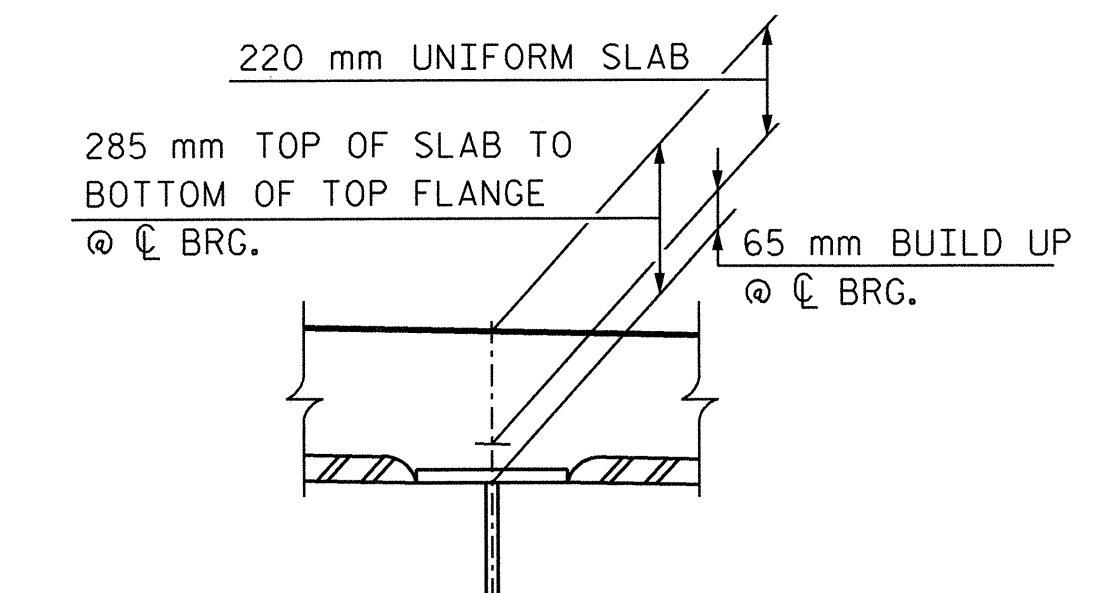

DETAIL "A"

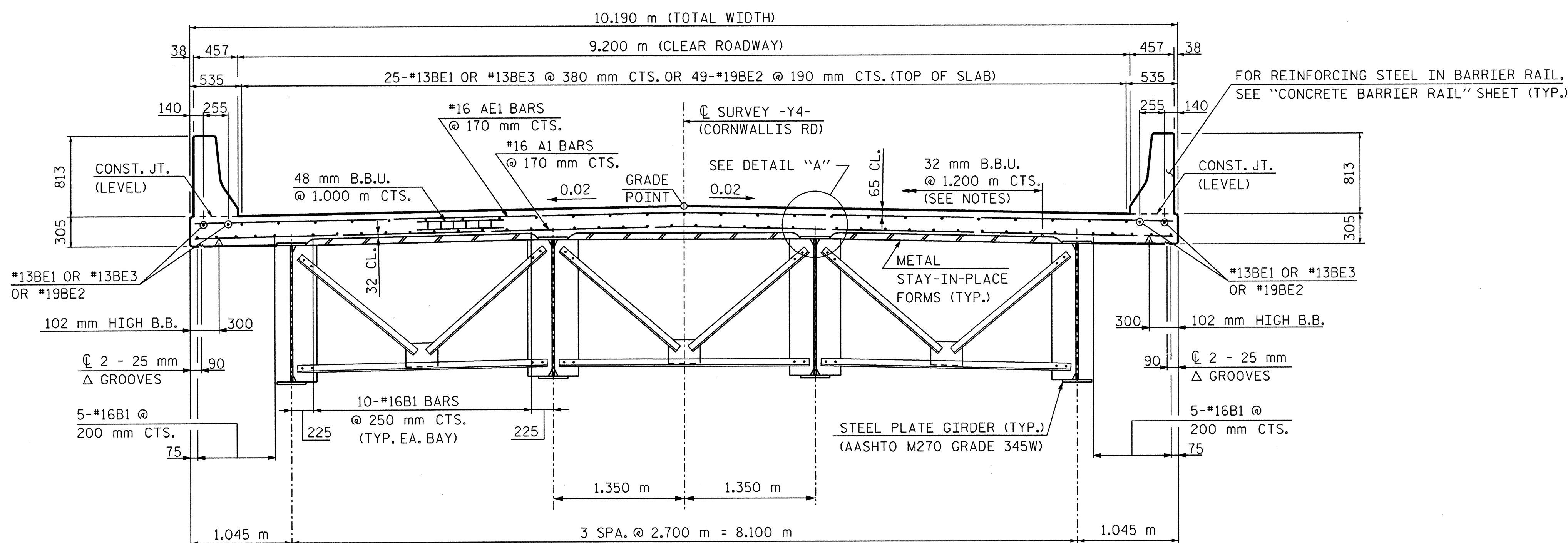

TYPICAL SECTION @ INTERMEDIATE AND BENT 1 DIAPHRAGM

PROJECT NO. R-2552AA
 WAKE / JOHNSTON COUNTY
 STATION: 27+61.028 -L- P.O.T.

SHEET 1 OF 2

STATE OF NORTH CAROLINA
 DEPARTMENT OF TRANSPORTATION
 RALEIGH

SUPERSTRUCTURE
 TYPICAL SECTION

JANUARY 2005

NO.		BY:		DATE:		NO.		BY:		DATE:		SHEET NO.	
1						3						5-231	
2						4						TOTAL SHEETS	429

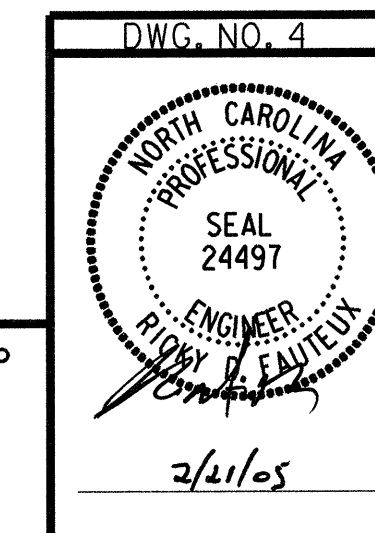

RUMMEL, KLEPPER & KAHL, LLP
 consulting engineers
 5800 FARINGDON PLACE - SUITE 105
 RALEIGH, NORTH CAROLINA 27609-3960

G:\COMMONS\304046\BRIDGE\SITES\DGN\FINAL\R2552AA.SD.TS1_05.DGN

DRAWN BY: B. PARRISH DATE: 01/05
 CHECKED BY: R. D. FAUTEUX DATE: 01/05