

**NOTES**

STEEL PILES SHALL MEET THE REQUIREMENTS OF ASTM A252 GRADE 2 AND SHALL BE GALVANIZED IN ACCORDANCE WITH THE STANDARD SPECIFICATIONS. THE DRIVING PLATE, IF REQUIRED, MAY BE GALVANIZED.

THE CONCRETE IN THE PLUG SHALL BE CLASS A CONCRETE.

STEEL PILES SHALL BE EXAMINED FOR DAMAGE OR COLLAPSE AFTER BEING DRIVEN AND PRIOR TO PLACING REINFORCING STEEL AND CONCRETE IN THE TOP OF THE PILE. REJECTED PILES SHALL BE REMOVED OR THE CONTRACTOR SHALL SUBMIT A PROPOSAL TO REPAIR THE PILE.

PILE SPLICES SHALL BE IN ACCORDANCE WITH THE STANDARD SPECIFICATIONS AND AWS D1.1. A MAXIMUM OF 2 PILE SPLICES PER PILE IS ALLOWED.

THE PILES SHALL BE DEWATERED TO THE SATISFACTION OF THE ENGINEER TO THE EXTENT NECESSARY TO OBTAIN THE MINIMUM CONCRETE PLUG WITHOUT FOULING THE CONCRETE.

THE CONCRETE PLUG WITHIN THE PILES SHALL BE FORMED SUCH THAT NO MOVEMENT OF THE REINFORCING STEEL OR CONCRETE OCCURS EITHER DURING OR AFTER THE CONCRETE PLACEMENT. THE CONCRETE PLUG SHALL BE CAST AND SHALL OBTAIN A MINIMUM COMPRESSIVE STRENGTH OF 1500 PSI PRIOR TO PLACING THE CONCRETE IN THE BENT CAP.

THE REINFORCING STEEL, CLASS A CONCRETE, AND DRIVING PLATE, IF REQUIRED, ARE CONSIDERED INCIDENTAL TO THE CONTRACT UNIT PRICE BID PER LINEAR FOOT FOR PP 18 X 0.50 STEEL PILES.

**BILL OF MATERIAL FOR ONE PP 18 X 0.50 STEEL PILE**

| BAR                 | NO. | SIZE | TYPE | LENGTH | WEIGHT |
|---------------------|-----|------|------|--------|--------|
| S1                  | 6   | #4   | 1    | 4'-5"  | 18     |
| V1                  | 8   | #5   | 2    | 6'-8"  | 56     |
| REINFORCING STEEL = |     |      |      | 74     | lbs    |

CLASS A CONCRETE  
5'-0" MINIMUM PLUG 0.3 CY

**BAR TYPES**

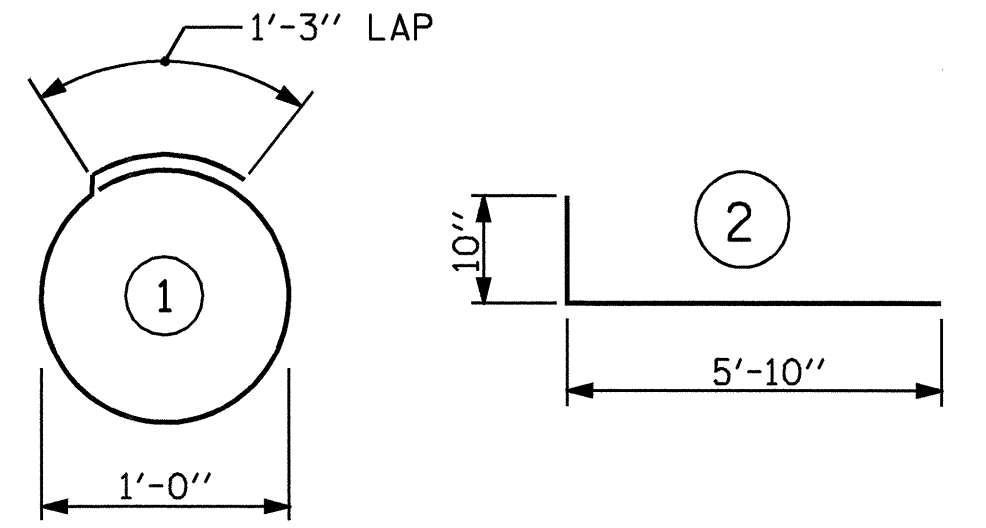

ALL BAR DIMENSIONS ARE OUT TO OUT.

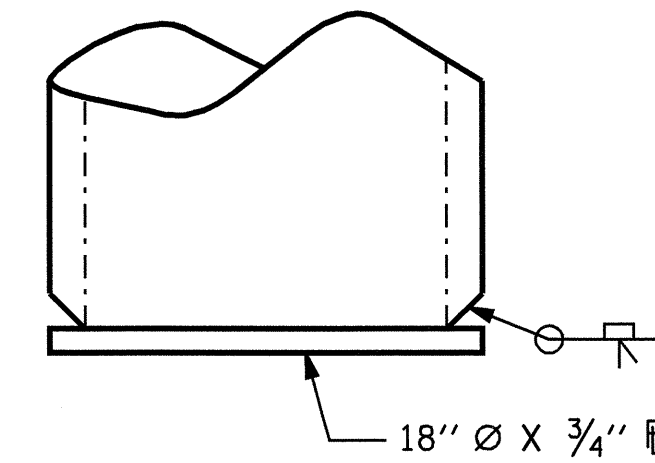

**DRIVING PLATE DETAIL**

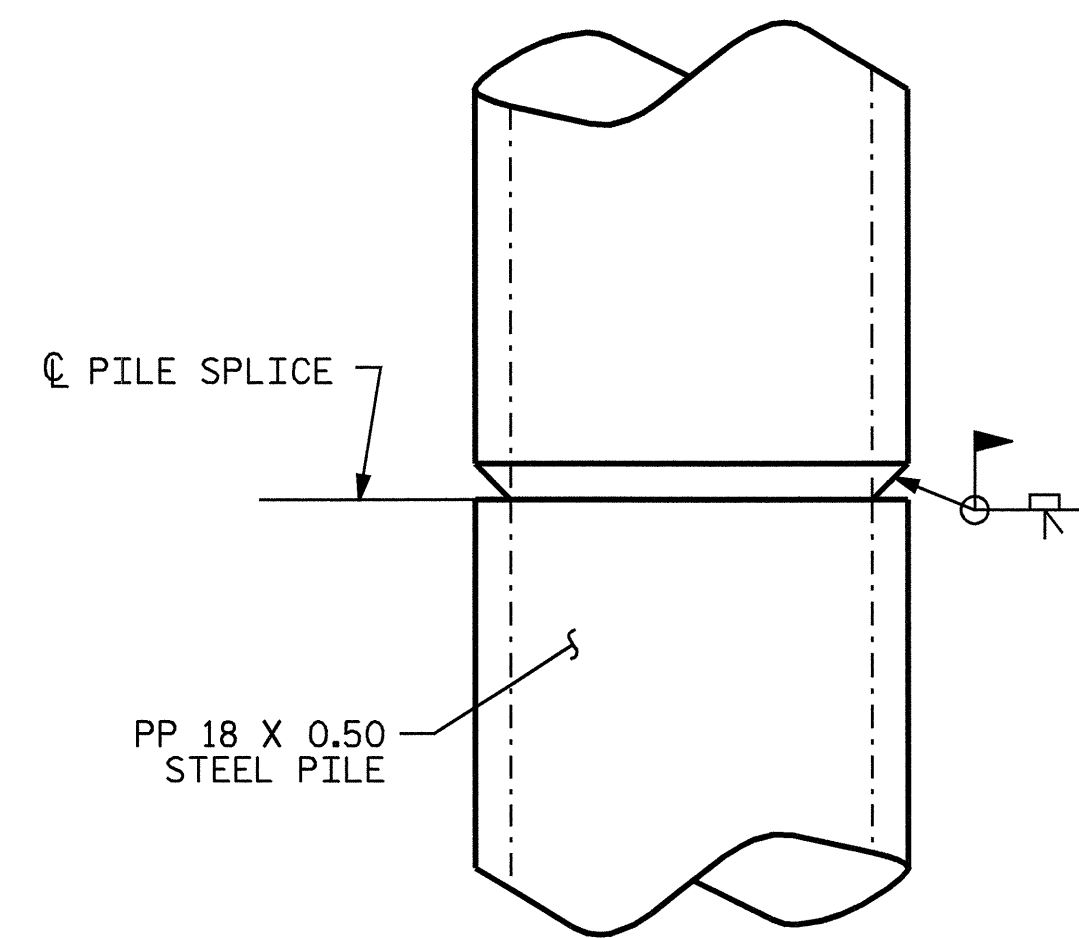

**PILE SPLICE DETAILS**

PROJECT NO. B-3682  
ONslow COUNTY  
STATION: 27+84.47 -L-

SHEET 3 OF 3

STATE OF NORTH CAROLINA  
DEPARTMENT OF TRANSPORTATION  
RALEIGH  
STANDARD  
18" STEEL PIPE PILE



|                              |              |
|------------------------------|--------------|
| ASSEMBLED BY : R. G. EMERSON | DATE : 06/04 |
| CHECKED BY : S. B. WILLIAMS  | DATE : 06/04 |
| DRAWN BY : RWW               | I/OI         |
| CHECKED BY : LES             | I/OI         |
| REV. 7/10/01                 | RWW/LES      |
| REV. 5/7/03                  | RWW/JTE      |

| REVISIONS |     |       |     |     |       | SHEET NO.    |
|-----------|-----|-------|-----|-----|-------|--------------|
| NO.       | BY: | DATE: | NO. | BY: | DATE: | TOTAL SHEETS |
| 1         |     |       | 3   |     |       | 26           |
| 2         |     |       | 4   |     |       | 26           |