

# STRUCTURAL STEEL NOTES

ALL STRUCTURAL STEEL SHALL BE AASHTO M270, GRADE 345W AND PAINTED IN ACCORDANCE WITH SYSTEM 4 OF ARTICLE 442-7 OF THE STANDARD SPECIFICATIONS, UNLESS OTHERWISE NOTED ON THE PLANS.

ALL DIMENSIONS SHOWN ARE HORIZONTAL OR VERTICAL UNLESS OTHERWISE NOTED.

BEARING STIFFENERS ARE TO BE PLACED NORMAL TO THE WEB OF THE GIRDER AND SHALL BE PLUMB.

MAIN TENSION MEMBERS SHALL BE CHARPY V-NOTCH (CVN) IMPACT TESTED IN ACCORDANCE WITH ARTICLE 1072-9 OF THE STANDARD SPECIFICATIONS. FOR THE PURPOSE OF IMPACT TESTING, THE FOLLOWING PLATES AND SHAPES SHALL BE CLASSIFIED AS MAIN TENSION MEMBERS.

- \* ALL FLANGE PLATES WHICH FALL WITHIN THE "TENSION ZONE", SEE "FRAMING PLAN AND GIRDER DETAILS" SHEETS.
- \* ALL WEB PLATES
- \* ALL GIRDER SPLICE PLATES
- \* ALL CROSSFRAME COMPONENTS
- \* ALL CROSSFRAME CONNECTOR PLATES AND GUSSET PLATES

FOR CHARPY V-NOTCH TESTS, SEE SPECIAL PROVISIONS.

NO WELDING OF FORMS OR FALSEWORK TO THE TOP FLANGE WILL BE PERMITTED IN THE "TENSION ZONES" AS INDICATED ON THE "FRAMING PLAN AND GIRDER DETAILS" SHEETS.

CAMBERED GIRDER LENGTHS SHALL BE ADJUSTED AND BEARINGS ARE TO BE PLACED ON THE CAMBERED GIRDER SO AS TO BE ALIGNED WITH THE ANCHORS AFTER THE DEAD LOAD DEFLECTION HAS OCCURRED. SHOP PLANS SHALL BE PREPARED ACCORDINGLY.

ALL FIELD CONNECTIONS SHALL BE MADE WITH 22.23mm DIA. (M22) M164 TYPE 3 HIGH STRENGTH BOLTS UNLESS OTHERWISE NOTED.

FOR EXTERIOR GIRDERS, CONNECTOR PLATES SHALL BE PLACED ON THE INSIDE FACE ONLY.

ENDS OF THE CONTINUOUS PLATE GIRDERS SHALL BE IN A PLUMB POSITION AFTER THE TOTAL DEAD LOAD DEFLECTION HAS OCCURRED.

SHOP SPLICES ARE PERMITTED TO LIMIT THE MAXIMUM REQUIRED FLANGE PIECE LENGTHS TO 18 METERS AND WEB PIECE LENGTHS TO 14 METERS. PERMITTED FLANGE AND WEB SHOP SPLICES SHALL NOT BE LOCATED WITHIN 4.5 METERS OF MAXIMUM DEAD LOAD DEFLECTION (NOR WITHIN 4.5 METERS OF INTERMEDIATE BEARINGS OF CONTINUOUS UNITS). KEEP 600mm MINIMUM BETWEEN WEB AND FLANGE SHOP SPLICES. KEEP 150mm MINIMUM BETWEEN CONNECTOR PLATE OR TRANSVERSE STIFFENER WELDS AND WEB OR FLANGE SHOP SPLICES.

THE CONTRACTOR SHALL MAINTAIN STABILITY OF CURVED GIRDERS UNTIL ALL FIELD SPLICES AND CROSSFRAME CONNECTIONS HAVE BEEN COMPLETED.

STRUCTURAL STEEL ERECTION IN A CONTINUOUS UNIT SHALL BE COMPLETE BEFORE FALSEWORK OR FORMS ARE PLACED ON THE UNIT.

FOR HEAT CURVING OF STEEL GIRDERS, SEE SPECIAL PROVISIONS.

STUDS ON GIRDERS MAY BE SHIFTED UP TO 25mm IF NECESSARY TO CLEAR FLANGE SPLICE WELDS, FIELD CONNECTION BOLTS AND FLANGE SPLICE PLATES.

TENSION ON AASHTO M164 BOLTS SHALL BE CALIBRATED USING DIRECT TENSION INDICATOR WASHERS IN ACCORDANCE WITH ARTICLE 440-10 OF THE STANDARD SPECIFICATIONS.

BEARING STIFFENER MAY REQUIRE COPING IF WIDER THAN BOTTOM FLANGE TO AVOID INTERFERENCE WITH ANCHOR BOLT.

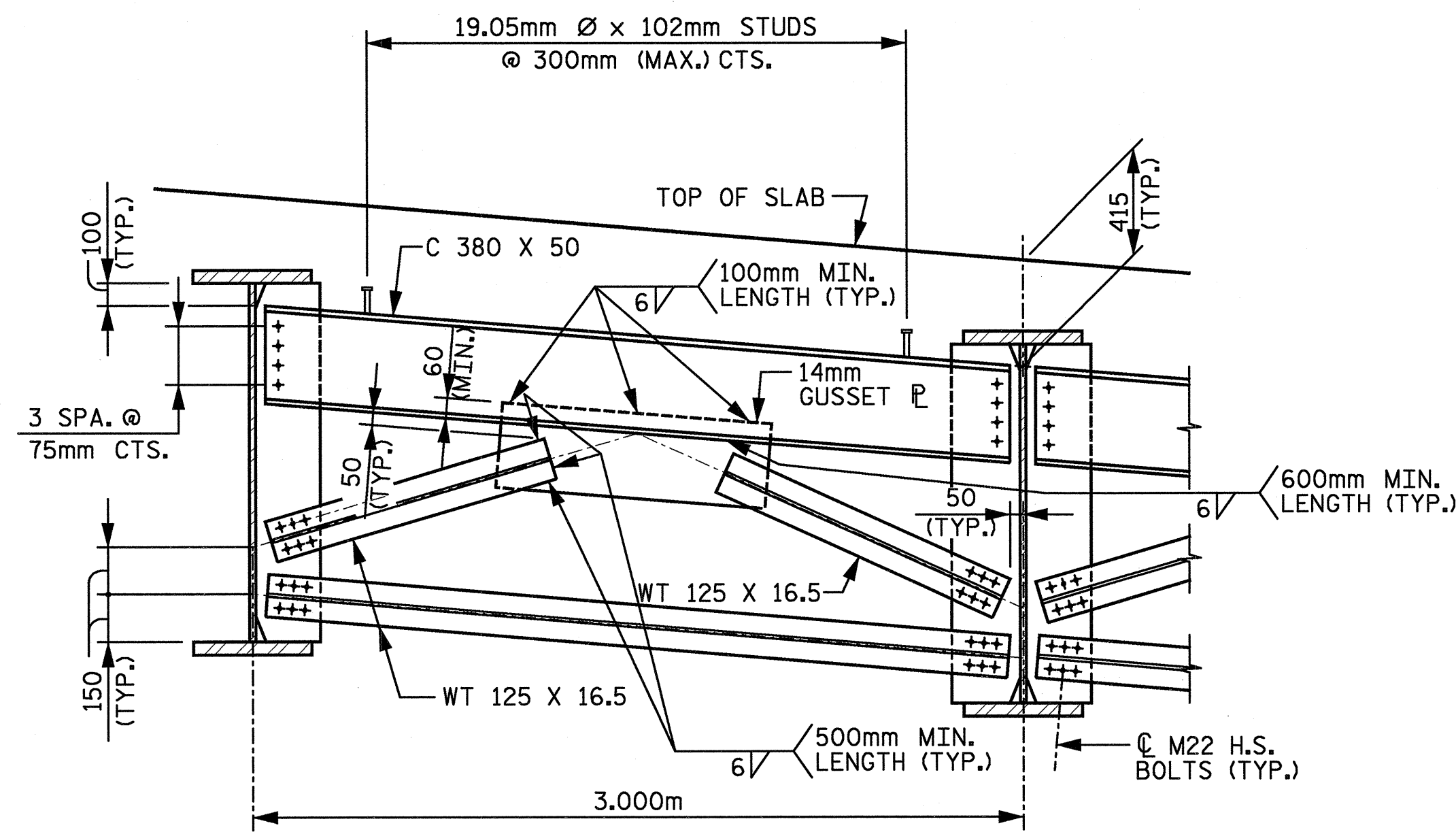

TYPICAL END CROSSFRAME

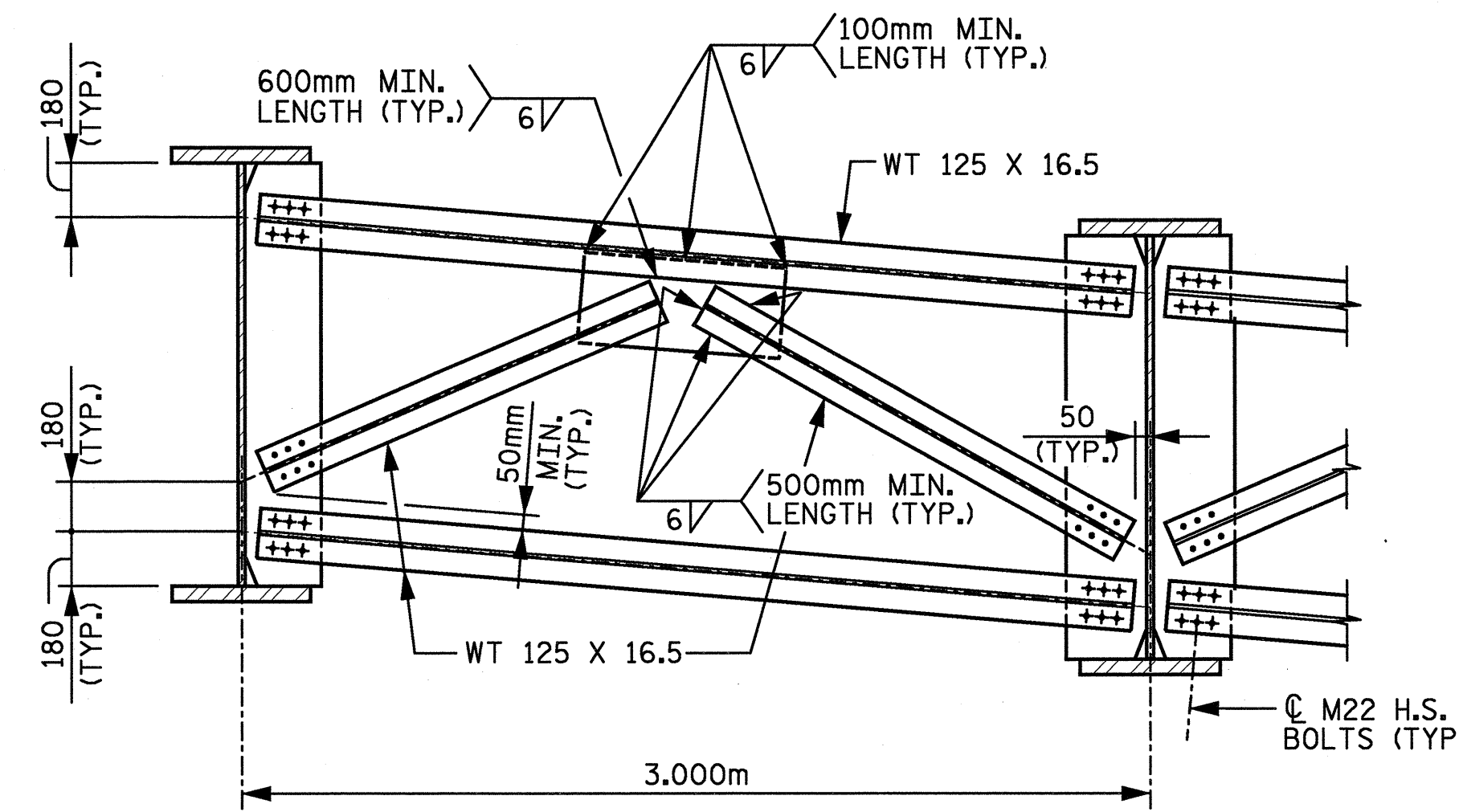

TYPICAL INTERMEDIATE CROSSFRAME

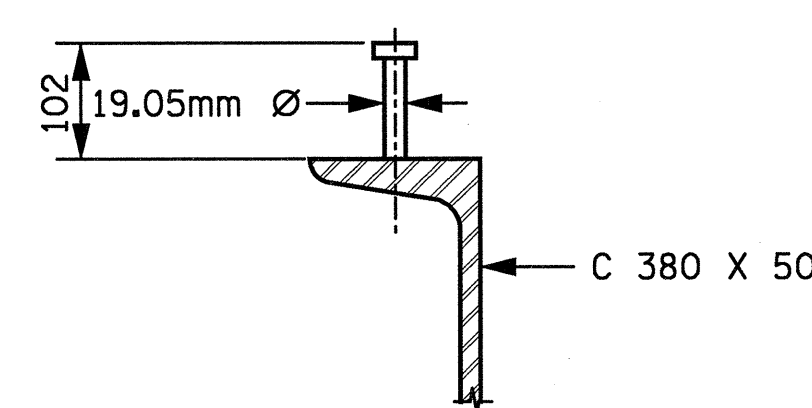

CHANNEL SHEAR STUD DETAIL

PROJECT No R-2552C  
 JOHNSTON COUNTY  
 STATION: POS 16+52.599 -Y4- =  
 POC 9+28.021 -FLYOVER-

SHEET 1 OF 2

STATE OF NORTH CAROLINA  
 DEPARTMENT OF TRANSPORTATION  
 RALEIGH  
 STRUCTURAL STEEL DETAILS

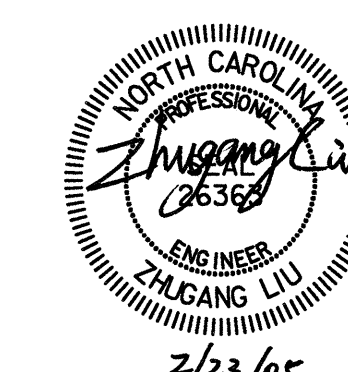
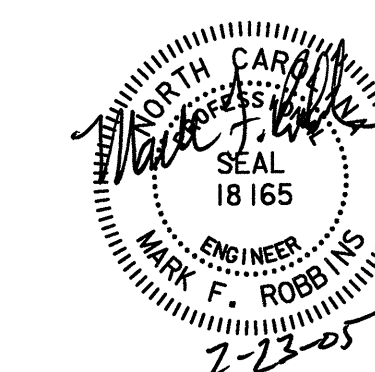

**W** RALPH WHITEHEAD ASSOCIATES, INC.  
 CONSULTING ENGINEERS  
 P.O. BOX 35624 CHARLOTTE, N.C. 28235  
 DRAWN BY WBS, LGH DATE 9-04 DWG. NO. D-1748.11  
 CHECKED BY TVR DATE 12-04

REVISIONS	
NO.	DATE
1	
2	
3	
4	

SHEET NO. 5-406  
 TOTAL SHEETS 431

02/23/2005 10:30:49 AM m:\proj\3109-300\ustation\struct\find\3109-300\_strsteel\_detail.Ldgn david.lowy