

HALF SECTION AT EXPANSION DIAPHRAGMS
END BENTS 1 & 2, & BENT 3

HALF SECTION AT CONTINUITY DIAPHRAGMS
BENTS 1, 2, 4 & 5

TYPICAL SECTION

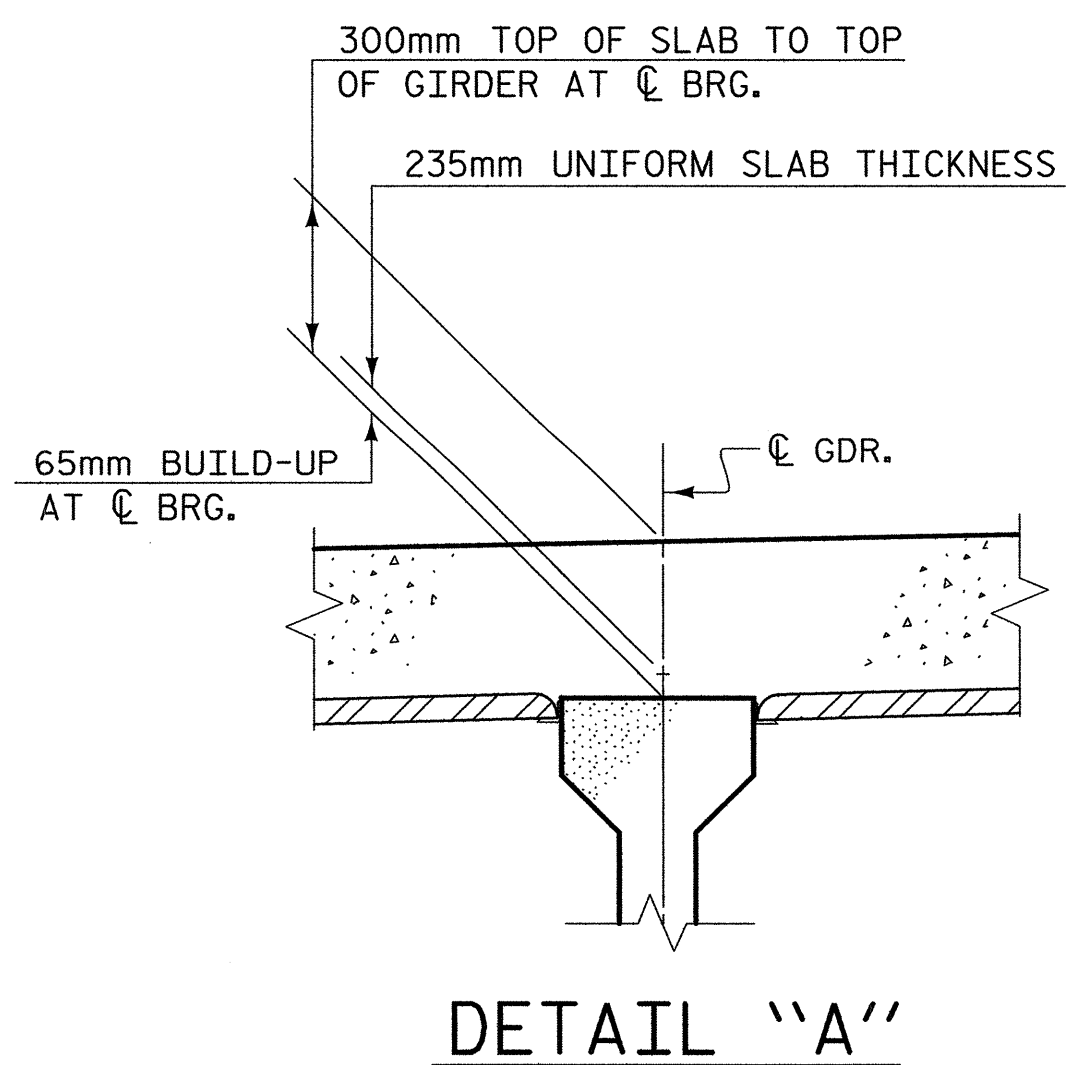

DETAIL "A"

NOTES:

- PROVIDE 32mm HIGH BEAM BOLSTERS UPPER (BBU) AT 1.2m CENTERS ATOP THE METAL STAY-IN-PLACE FORMS TO SUPPORT THE BOTTOM MAT OF "A" BARS.
- WHEN USING REMOVABLE FORMS, PROVIDE CONTINUOUS HIGH CHAIRS FOR METAL DECK (C.H.C.M.) @ 1.2m CTS. WITH A HEIGHT TO SUPPORT THE BOTTOM MAT OF "A" BARS A CLEAR DISTANCE OF 65mm ABOVE THE TOP OF THE REMOVABLE FORM.
- TEMPORARY STRUTS SHALL BE PLACED BETWEEN PRESTRESSED CONCRETE GIRDERS ADJACENT TO THE INTERMEDIATE DIAPHRAGMS AND THE NUTS ON THE 31.75mm Ø TIE RODS SHALL BE FULLY TIGHTENED BEFORE DIAPHRAGMS ARE CAST. STRUTS SHALL REMAIN IN PLACE THREE (3) DAYS AFTER CONCRETE IS PLACED. THE TIE RODS SHALL BE RETIGHTENED AFTER THE STRUTS HAVE BEEN REMOVED.
- CONCRETE IN INTERMEDIATE DIAPHRAGMS MAY BE CLASS A IN LIEU OF CLASS AA. PAYMENT SHALL BE MADE UNDER THE UNIT CONTRACT PRICE BID FOR REINFORCED CONCRETE DECK SLAB.
- FOR REINFORCING STEEL BARS INDICATED, BUT NO MARK SHOWN SEE PLAN OF SPANS.
- CONCRETE BARRIER RAIL IN A CONTINUOUS UNIT SHALL NOT BE CAST UNTIL ALL SLAB CONCRETE IN THE UNIT HAS BEEN CAST AND HAS REACHED A MINIMUM COMPRESSIVE STRENGTH OF 20.7 MPa.
- LONGITUDINAL STEEL MAY BE SHIFTED AS NECESSARY TO AVOID INTERFERENCE WITH STIRRUPS IN PRESTRESSED CONCRETE GIRDERS.
- PREVIOUSLY CAST CONCRETE IN A CONTINUOUS UNIT SHALL HAVE ATTAINED A MINIMUM COMPRESSIVE STRENGTH OF 20.7 MPa BEFORE ADDITIONAL CONCRETE IS CAST IN THE UNIT.

* EPOXY COATED REINFORCING STEEL

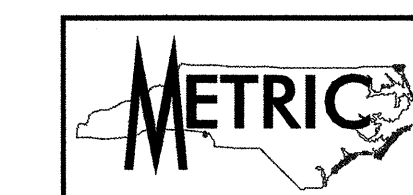

PROJECT NO. R-2552C
JOHNSTON COUNTY
STATION: 109+56.000 -L2LT- POT

SHEET 1 OF 2

STATE OF NORTH CAROLINA
DEPARTMENT OF TRANSPORTATION
RALEIGH

SUPERSTRUCTURE
TYPICAL SECTION
(LEFT LANE)

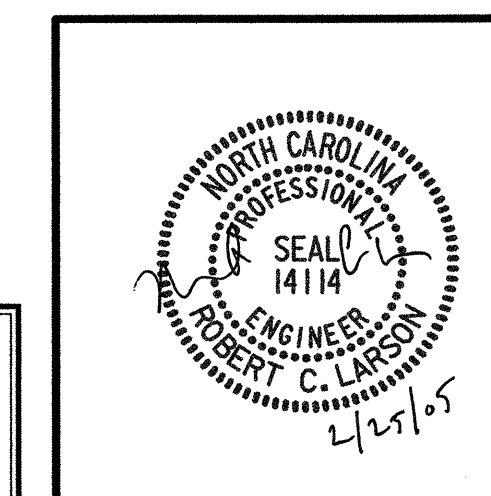

REVISIONS				SHEET NO.	
NO.	BY:	DATE:	NO.	BY:	DATE:
1			3		
2			4		

TOTAL SHEETS: 431

REFERENCE NO. BL-5

02/21/2005 04:40:33 PM G:\Projects\2004\2525\DR-2525\Structures\518e\Leff\Line\RES52C-SD.TS.dgn

DRAWN BY: W. B. ALLEN DATE: 6/04
CHECKED BY: R. C. LARSON DATE: 10/04