

NOTES

ALL PRESTRESSING STRANDS SHALL BE 7-WIRE LOW-RELAXATION GRADE 270 STRANDS AND SHALL CONFORM TO AASHTO M203M EXCEPT FOR SAMPLING REQUIREMENTS WHICH SHALL BE IN ACCORDANCE WITH THE STANDARD SPECIFICATIONS.

TIE ROD ASSEMBLY SHALL BE AASHTO M270 GRADE 250 STRUCTURAL STEEL.

ALL REINFORCING STEEL SHALL BE GRADE 420.

APPLY EPOXY PROTECTIVE COATING TO END OF GIRDER SURFACES INDICATED IN ELEVATION VIEW. FOR EPOXY PROTECTIVE COATING, SEE SPECIAL PROVISIONS.

EMBEDDED PLATE "B-1" SHALL BE GALVANIZED IN ACCORDANCE WITH THE SPECIFICATIONS. BEVEL EDGES OF PLATE "B-1" TO GIVE CLOSE FIT BUT NOT TIGHT FIT TO STEEL CASTING FORM.

ANCHOR STUDS SHALL CONFORM TO AASHTO M169 GRADES 1010 THROUGH 1020 OR APPROVED EQUAL, AND SHALL MEET THE TYPE "B" REQUIREMENTS OF SUBSECTION 7.3 OF THE ANSI/AASHTO/AWS D1.5 BRIDGE WELDING CODE.

AT ENDS OF GIRDERS TO BE EMBEDDED IN CONCRETE DIAPHRAGMS OR END WALLS, PRESTRESSING STRANDS MAY EXTEND A MAXIMUM OF 50mm BEYOND THE GIRDER ENDS. OTHERWISE, PRESTRESSING STRANDS SHALL BE CUT FLUSH WITH THE GIRDER ENDS.

THE TRANSFER OF LOAD FROM THE ANCHORAGES TO THE GIRDER SHALL BE DONE WHEN CONCRETE HAS REACHED A COMPRESSIVE STRENGTH OF NOT LESS THAN 33 MPa.

DEPENDING ON THE TYPE OF SYSTEM USED TO SUPPORT THE DECK SLAB FORMS, PRESET ANCHORS MAY BE NECESSARY IN THE PRESTRESSED CONCRETE GIRDER.

THE TOP SURFACE OF THE GIRDER, EXCLUDING THE OUTSIDE 100mm, SHALL BE RAKED TO A DEPTH OF 6mm.

WHEN DRAPED STRANDS ARE DETAILED, THE LONGITUDINAL LOCATION OF THE HOLD-DOWN DEVICES SHALL BE WITHIN 150mm OF THE LOCATION SHOWN AND THE CENTER OF GRAVITY OF THE GROUP OF DRAPED STRANDS SHALL BE LOCATED WITHIN 13mm OF THE THEORETICAL LOCATION SHOWN.

A 50mm x 50mm CHAMFER IS ALLOWED AT THE INTERSECTION OF THE WEB AND THE BOTTOM FLANGE OF THE 1600mm AND 1829mm MODIFIED BULB TEES ONLY.

FOR VERTICAL CRACKS IN PRESTRESSED CONCRETE GIRDERS PRIOR TO DETENSIONING, SEE SPECIAL PROVISIONS.

THE CONTRACTOR HAS THE OPTION TO PROVIDE, AT NO ADDITIONAL COST TO THE DEPARTMENT, 2 ADDITIONAL STRANDS AT THE TOP OF THE GIRDER TO FACILITATE TYING OF THE REINFORCING STEEL. THESE STRANDS SHALL BE PULLED TO A LOAD OF 20 Kn.

FOR PRESTRESSED CONCRETE MEMBERS, SEE SPECIAL PROVISIONS.

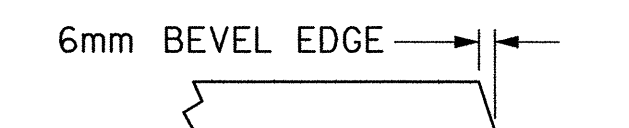

SECTION "G"

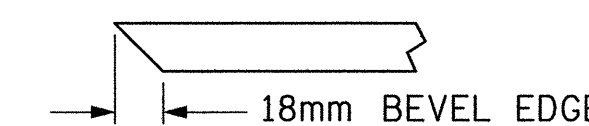

SECTION "F"

(SEE NOTES)

PROJECT NO. R-2552C

JOHNSTON COUNTY

STATION: 109+56.000 -L2LT- POT

SHEET 3 OF 3

STATE OF NORTH CAROLINA
DEPARTMENT OF TRANSPORTATION
RALEIGH

STANDARD
PRESTRESSED CONCRETE GIRDER
CONTINUOUS FOR LIVE LOAD
DETAILS
(LEFT LANE)
STD. NO. PCG11SM

REVISIONS					SHEET NO.
NO.	BY:	DATE:	NO.	BY:	DATE:
1			3		
2			4		

5-198
TOTAL SHEETS
431

THIS STANDARD DRAWING REVIEWED & ADOPTED FOR USE AT THE REFERENCED LOCATION BY THE UNDERSIGNED:



REFERENCE NO. BL-15

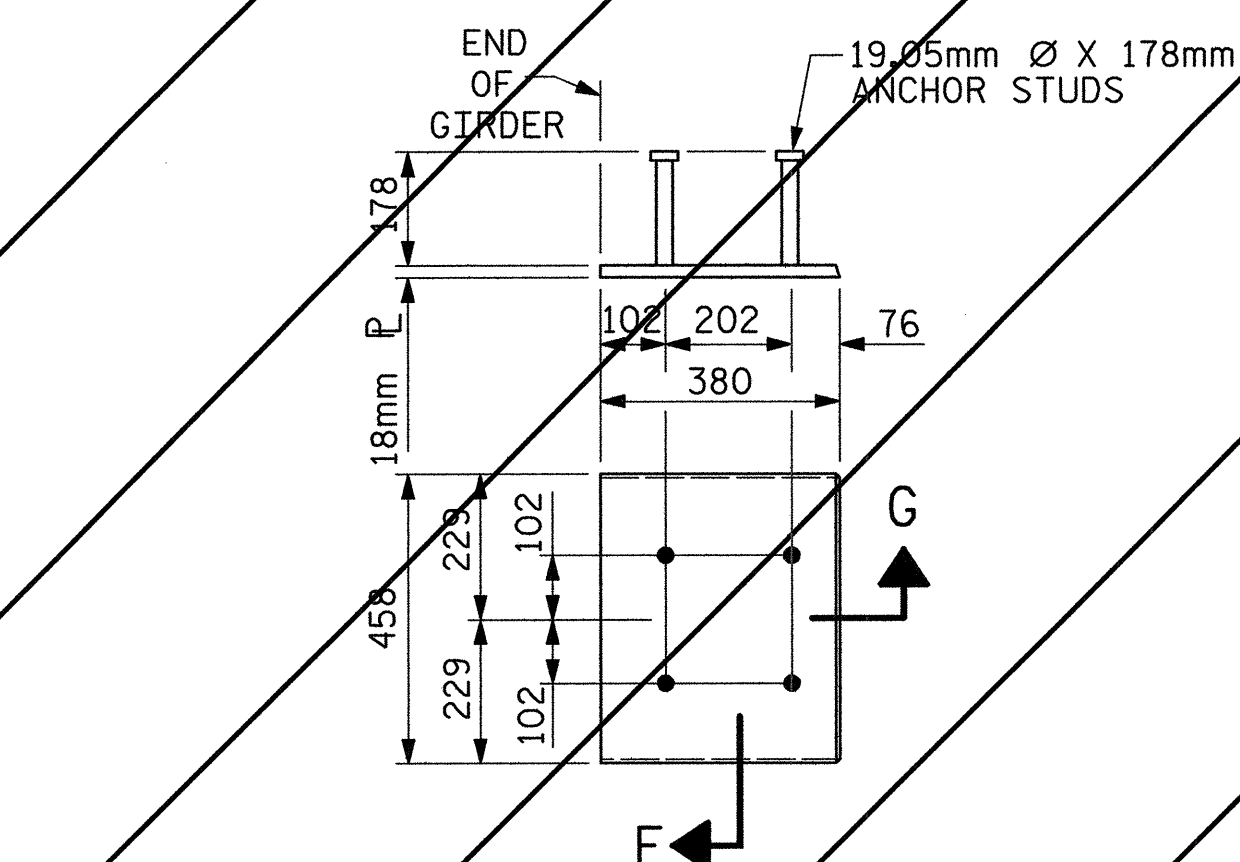

EMBEDDED PLATE "B-1" DETAILS FOR AASHTO TYPE II GIRDER
(2 REQ'D PER GIRDER)

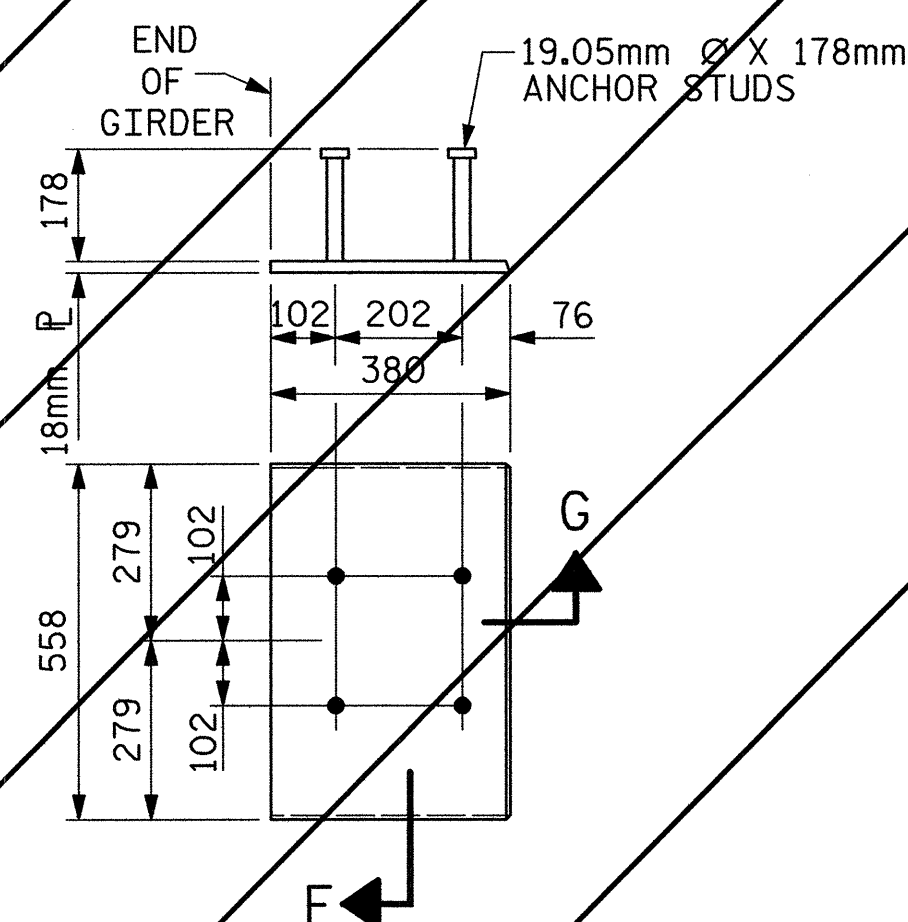

EMBEDDED PLATE "B-1" DETAILS FOR AASHTO TYPE III GIRDER
(2 REQ'D PER GIRDER)

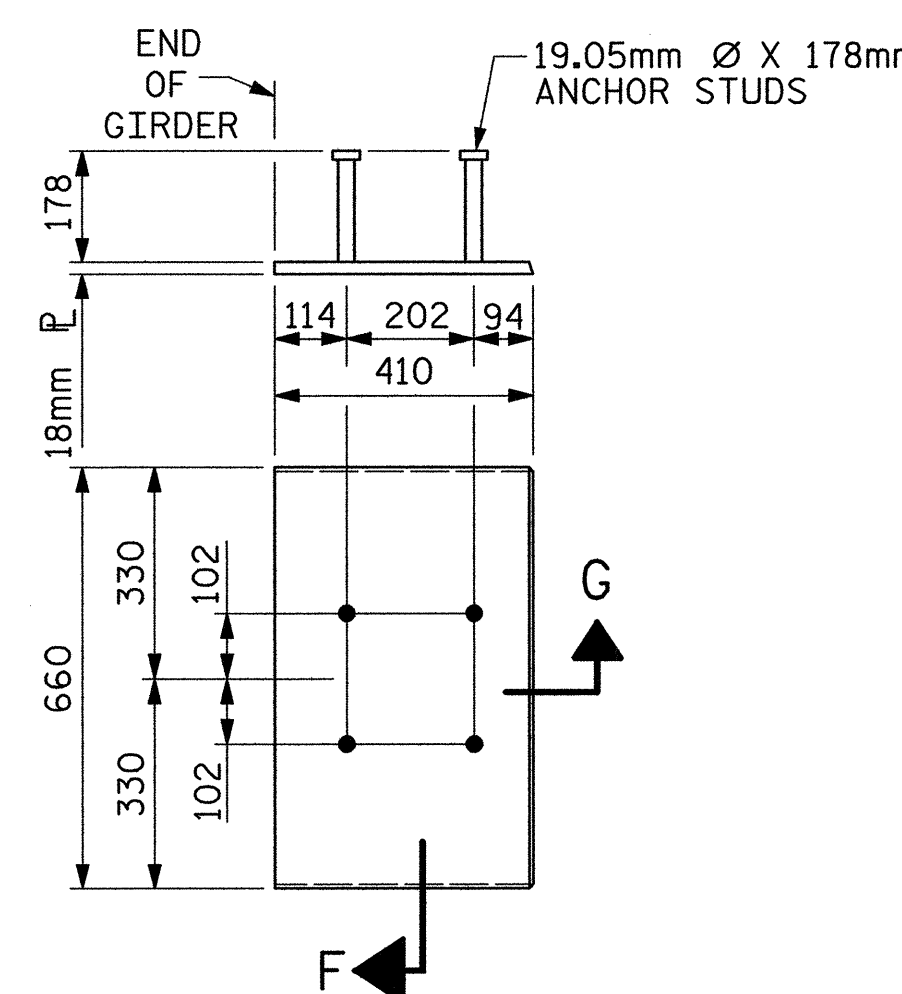

EMBEDDED PLATE "B-1" DETAILS FOR AASHTO TYPE IV GIRDER 1600mm & 1829mm MODIFIED BULB TEES
(2 REQ'D PER GIRDER)

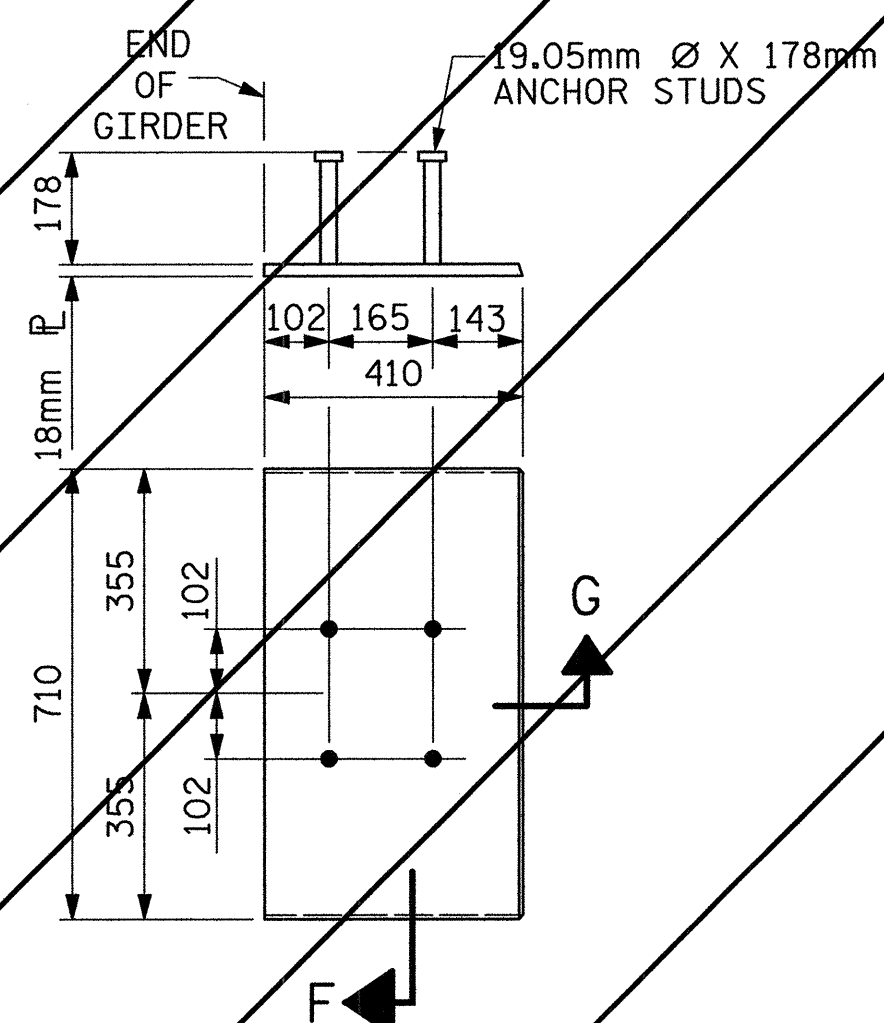

EMBEDDED PLATE "B-1" DETAILS FOR AASHTO TYPE V & TYPE VI GIRDERS
(2 REQ'D PER GIRDER)

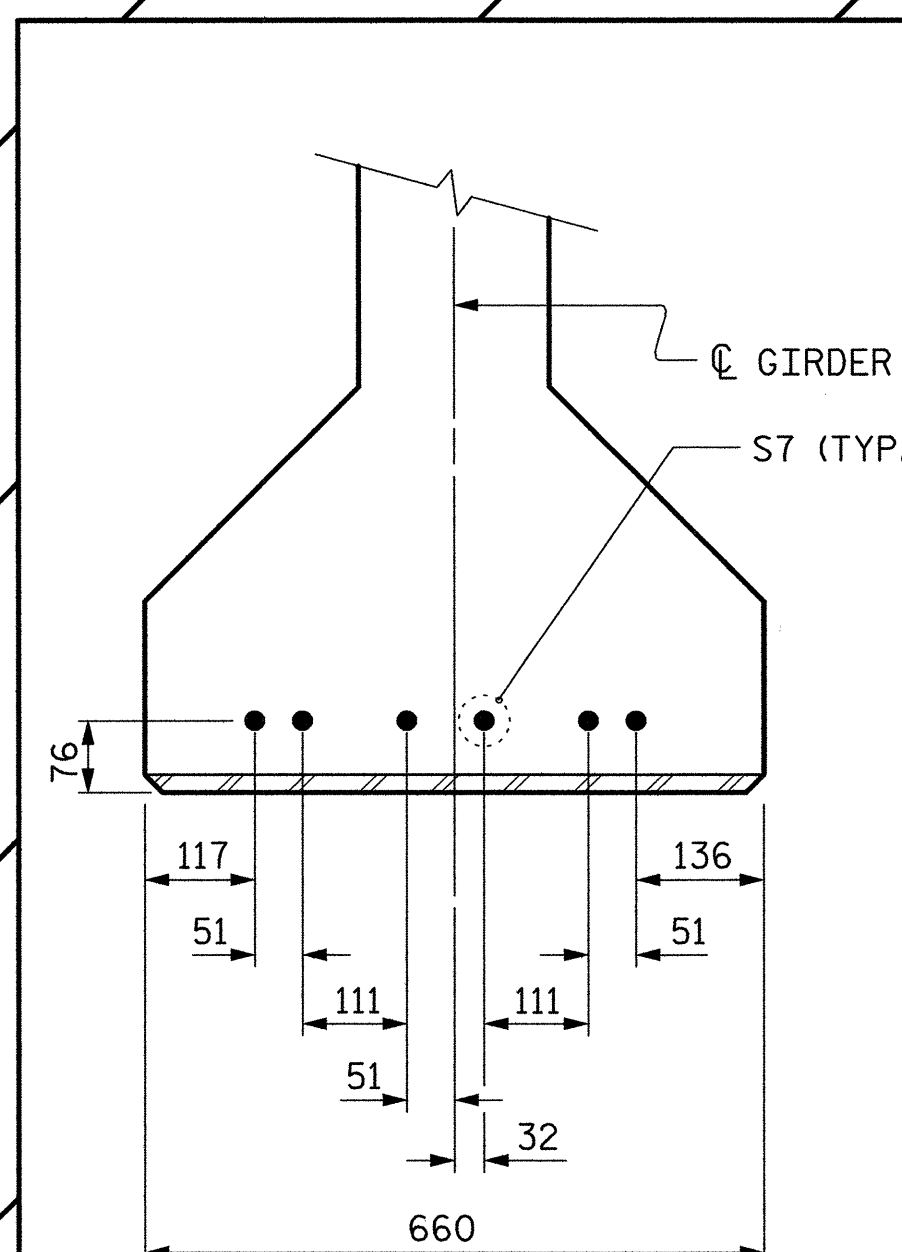

DETAIL "A"
(FOR AASHTO TYPE IV GIRDERS)

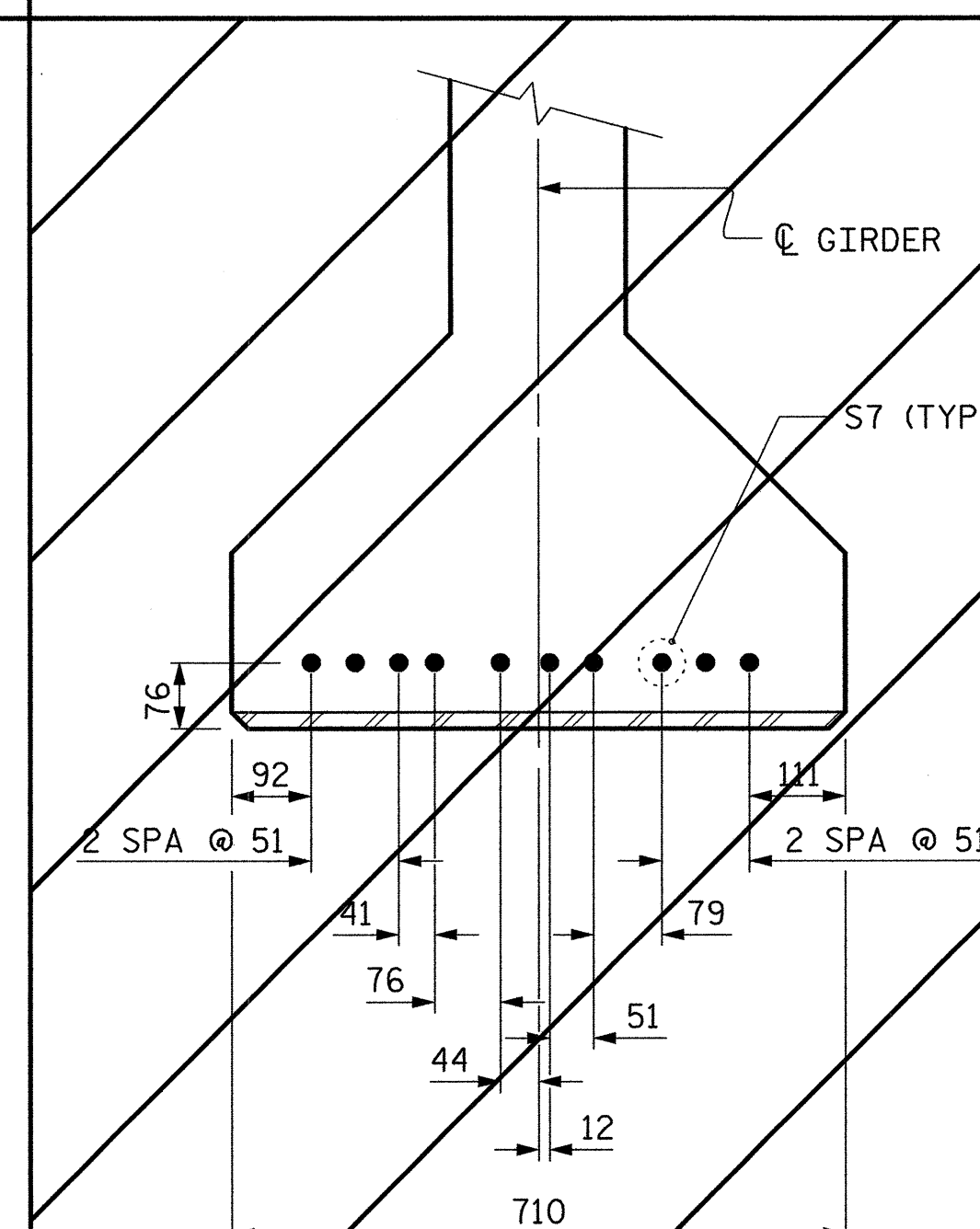

DETAIL "B"
(FOR AASHTO TYPE V & VI GIRDERS)

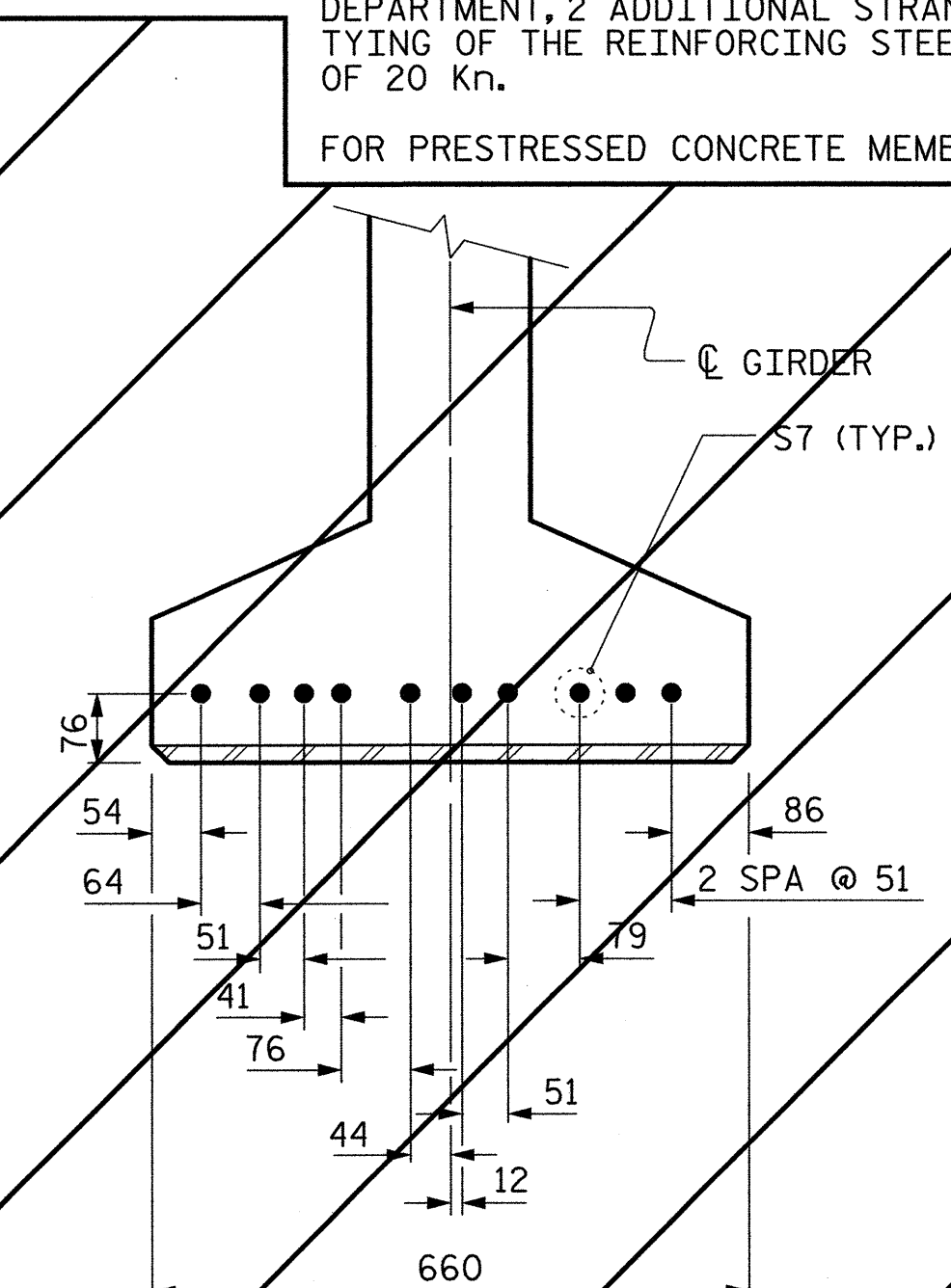

DETAIL "C"
(FOR 1600mm & 1829mm MODIFIED BULB TEES)

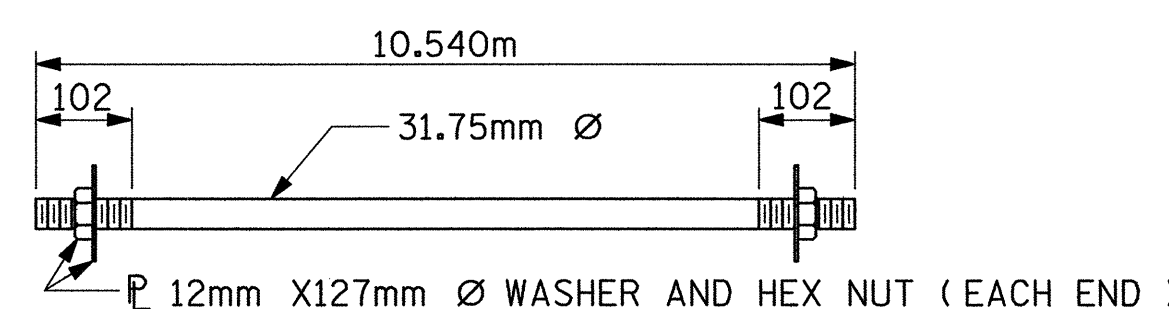

31.75mm Ø TIE ROD ASSEMBLY
(6 COMPLETE ASSEMBLIES REQUIRED)

02/21/2005 07:04:44 AM F:\Structures\Site\Left\Drawings\2552C-SD-G-03.dgn

ASSEMBLED BY : W. B. ALLEN	DATE : 9/04
CHECKED BY : R. C. LARSON	DATE : 10/04
DRAWN BY : ELR 11/91	REV. 8/16/99 MAB/LES
CHECKED BY : GRP 11/91	REV. 10/17/00 RWW/LES
	REV. 7/10/01 LES/RDR