

TYPICAL SECTION

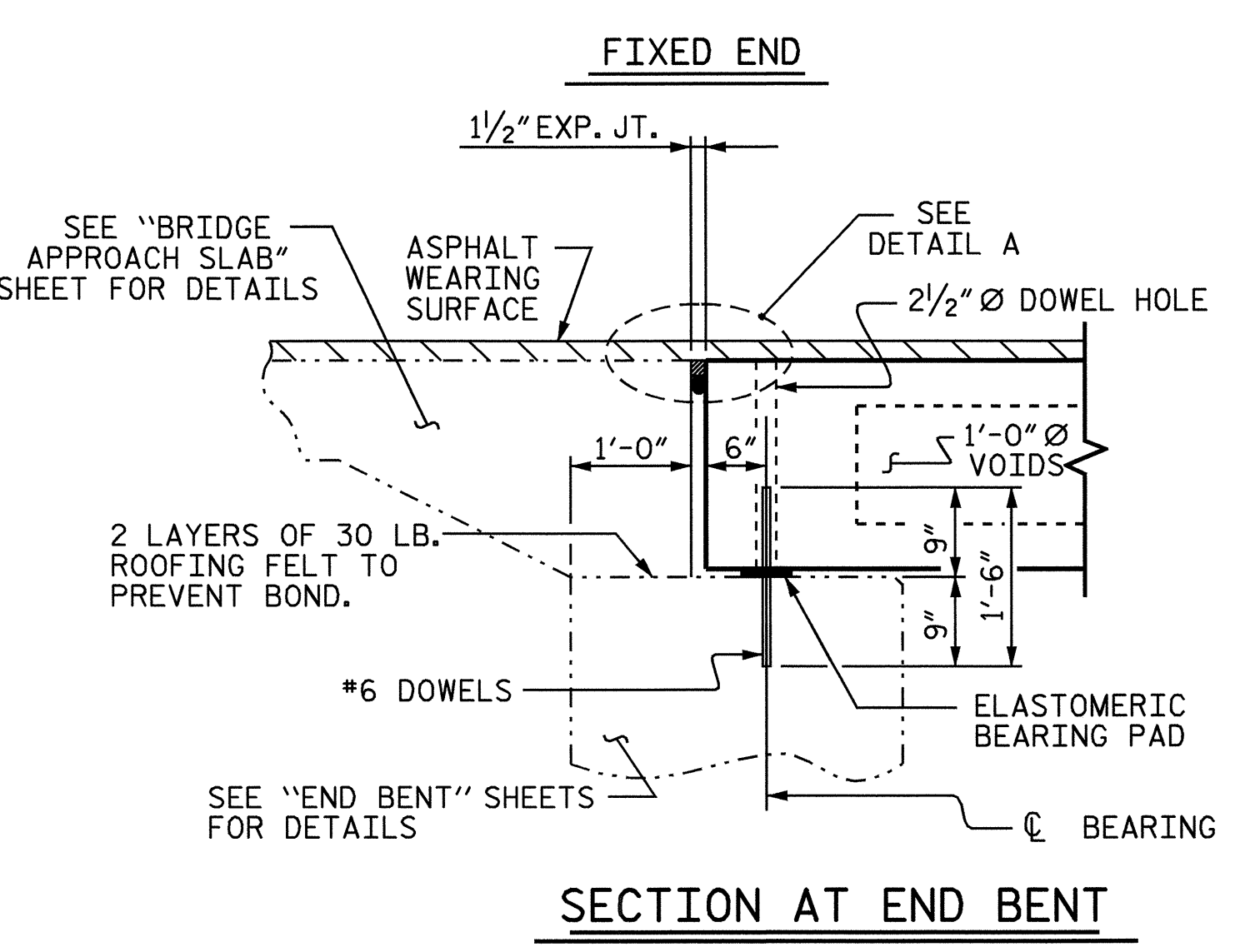

SECTION AT END BENT

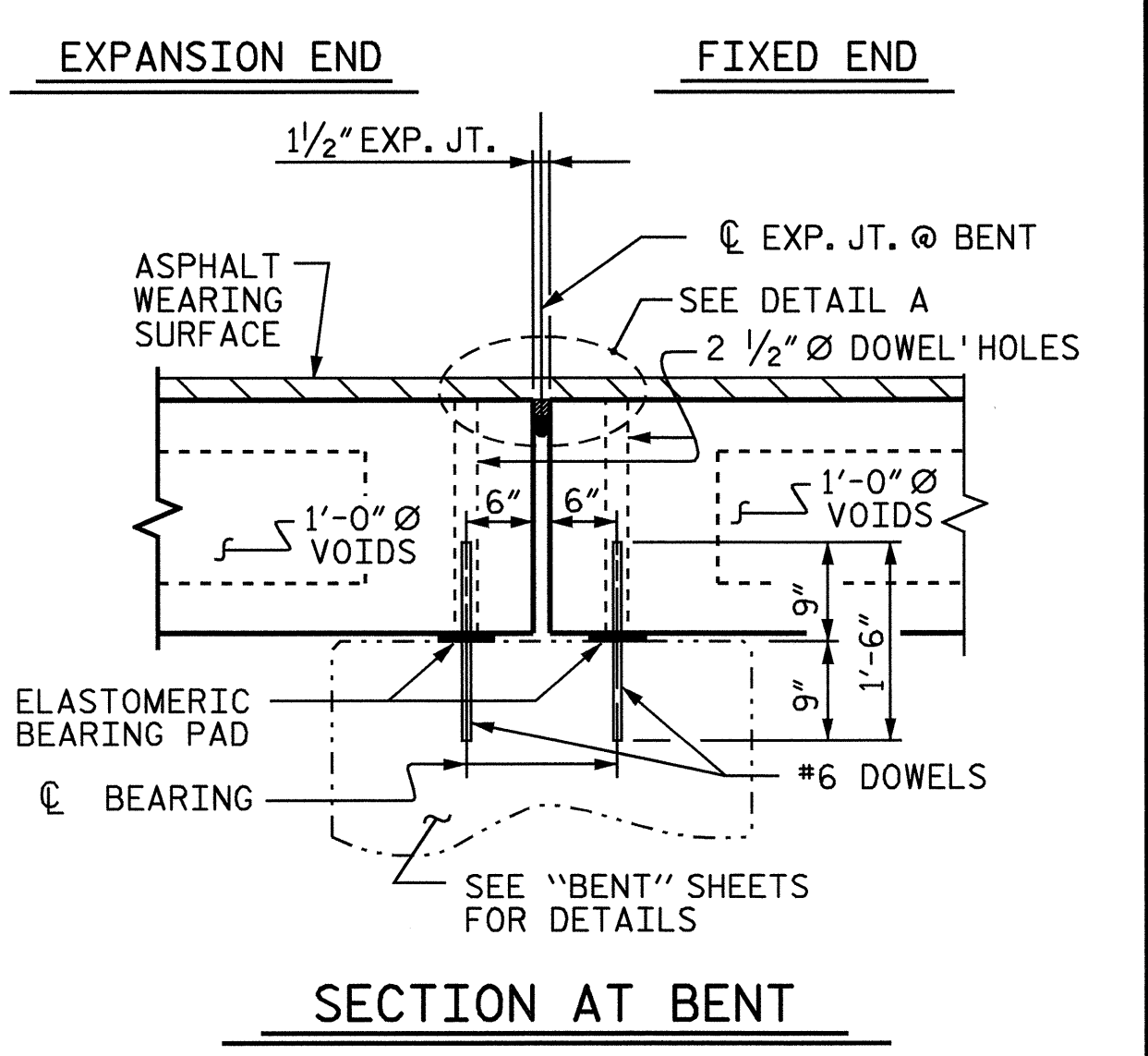

SECTION AT BENT

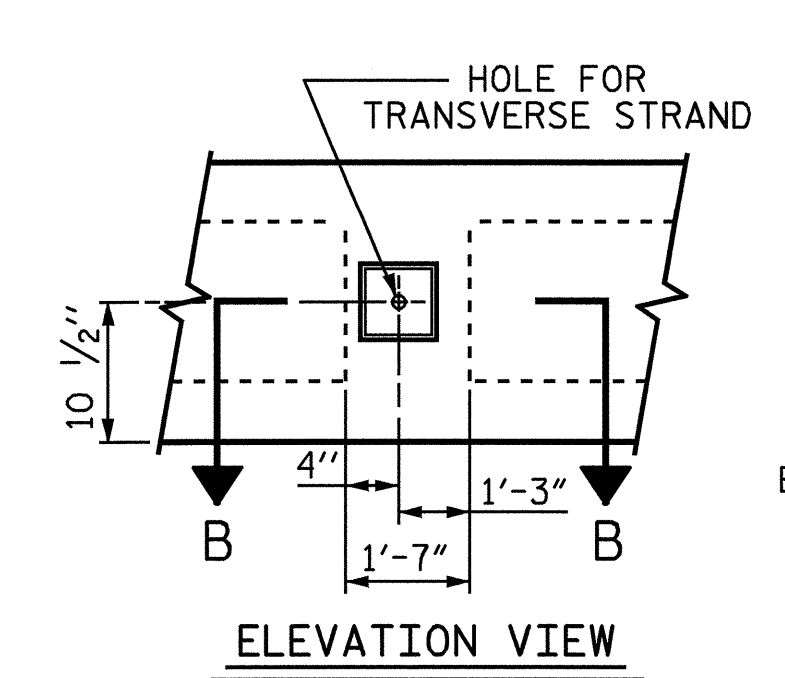

ELEVATION VIEW

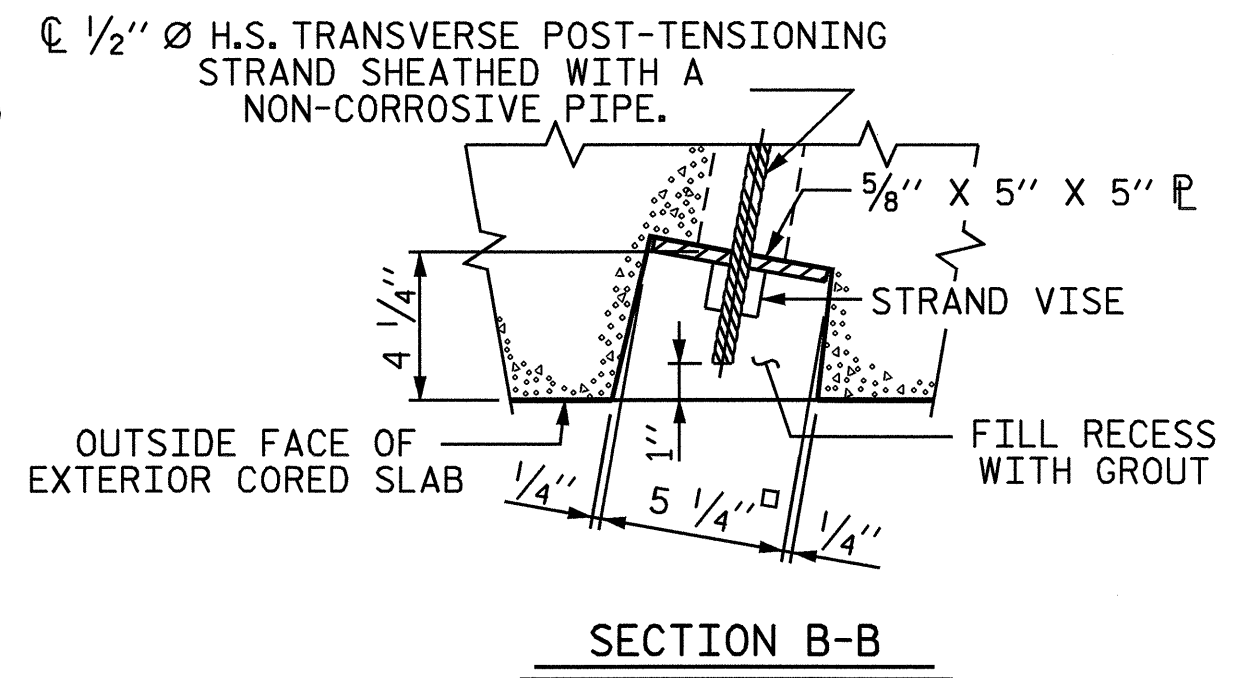

SECTION B-B

GROUTED RECESS AT END OF POST-TENSIONED STRAND CORED SLABS

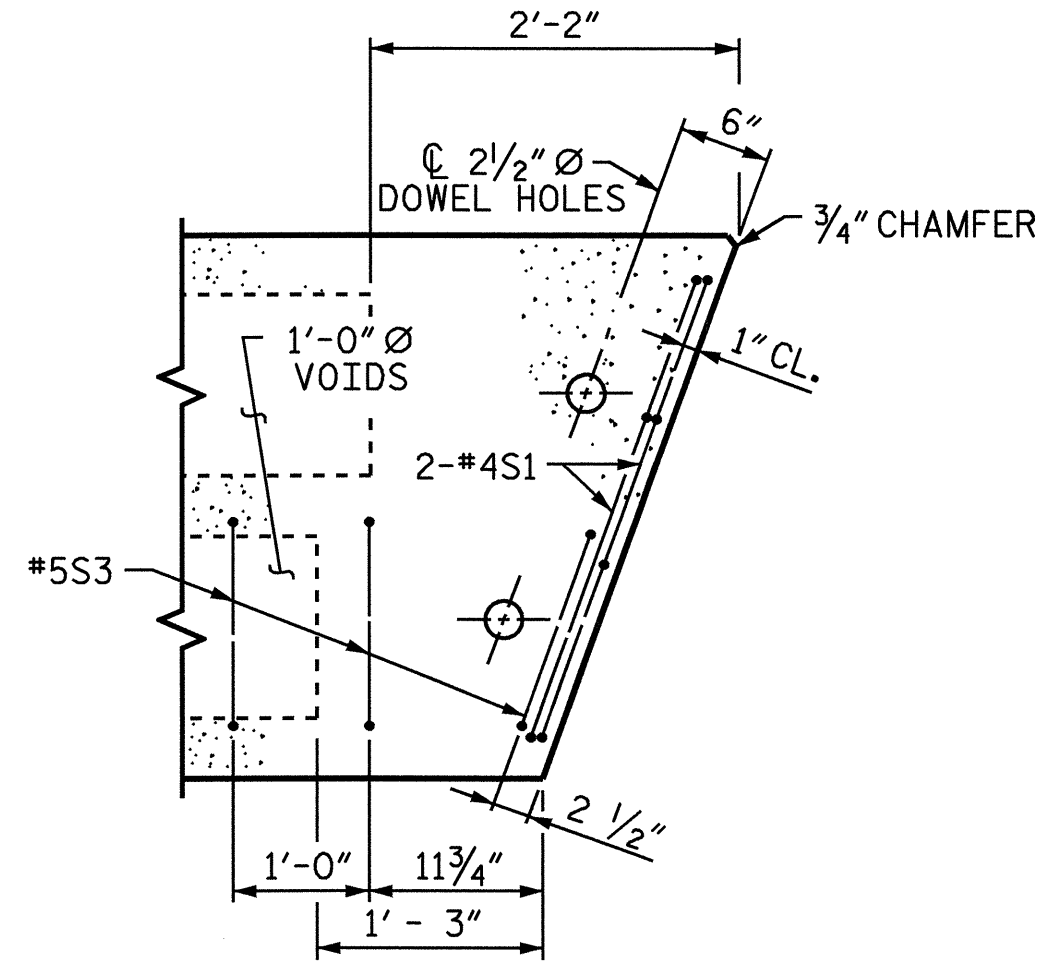

PART PLAN-EXTERIOR SECTION

NOTE: EXTERIOR SECTION SHOWN-INTERIOR SECTION SIMILAR EXCEPT OMIT S3 BARS. SEE PLAN OF SPAN FOR DIMENSION A.

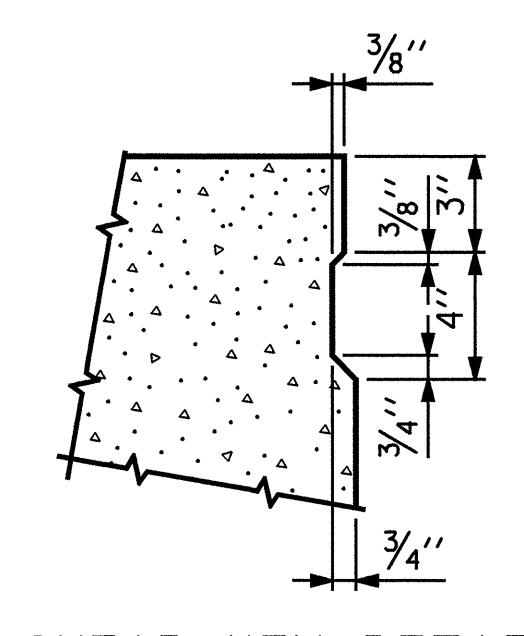

SHEAR KEY DETAIL

NOTE: OMIT SHEAR KEY ON OUTSIDE FACE OF EXTERIOR CORED SLABS.

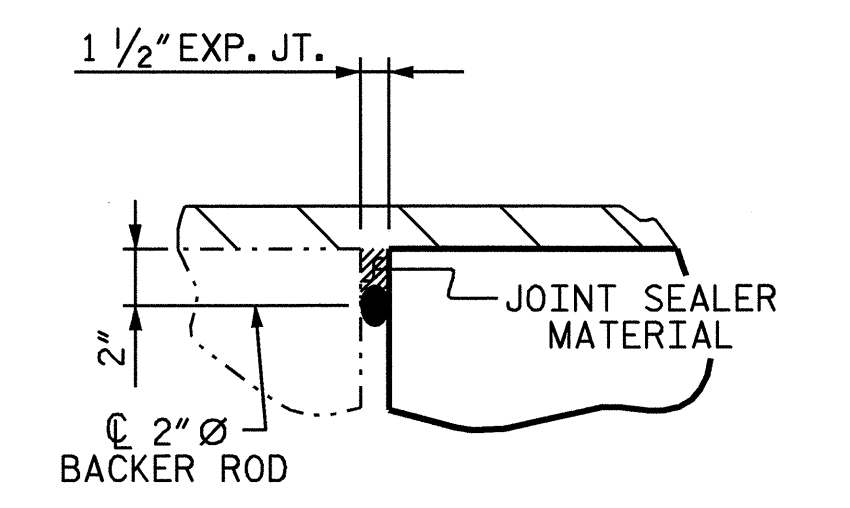

DETAIL A

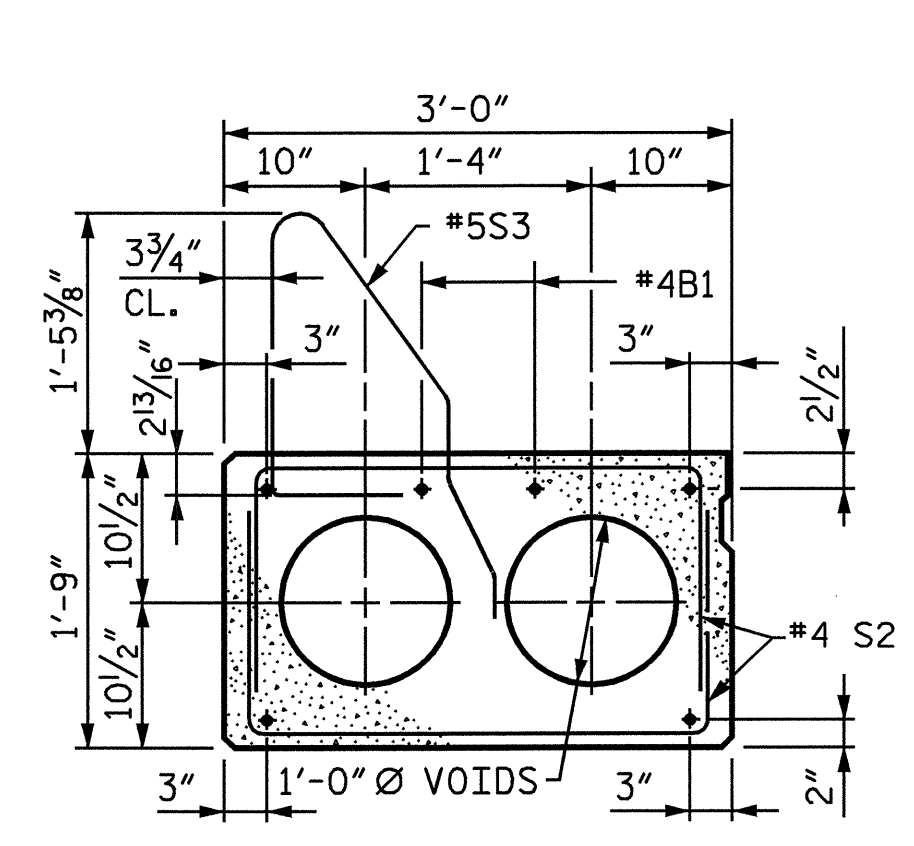

EXTERIOR SLAB SECTION

(FOR PRESTRESSED STRAND LAYOUT, SEE INTERIOR SLAB SECTION.)

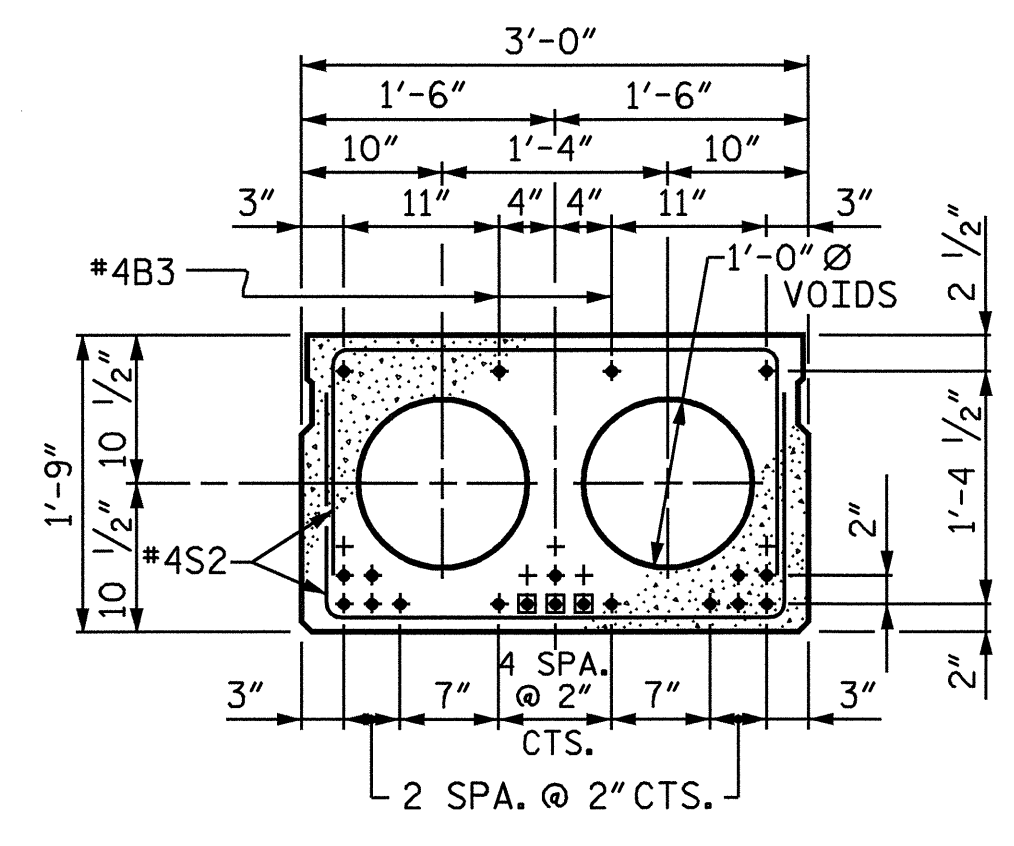

INTERIOR SLAB SECTION SPAN B

1/2" Ø LOW RELAXATION STRAND LAYOUT

■ BOND SHALL BE BROKEN ON THESE STRANDS FOR A DISTANCE OF 4'-0" FROM END OF CORED SLAB UNIT. SEE STANDARD SPECIFICATIONS, ARTICLE 1078-7

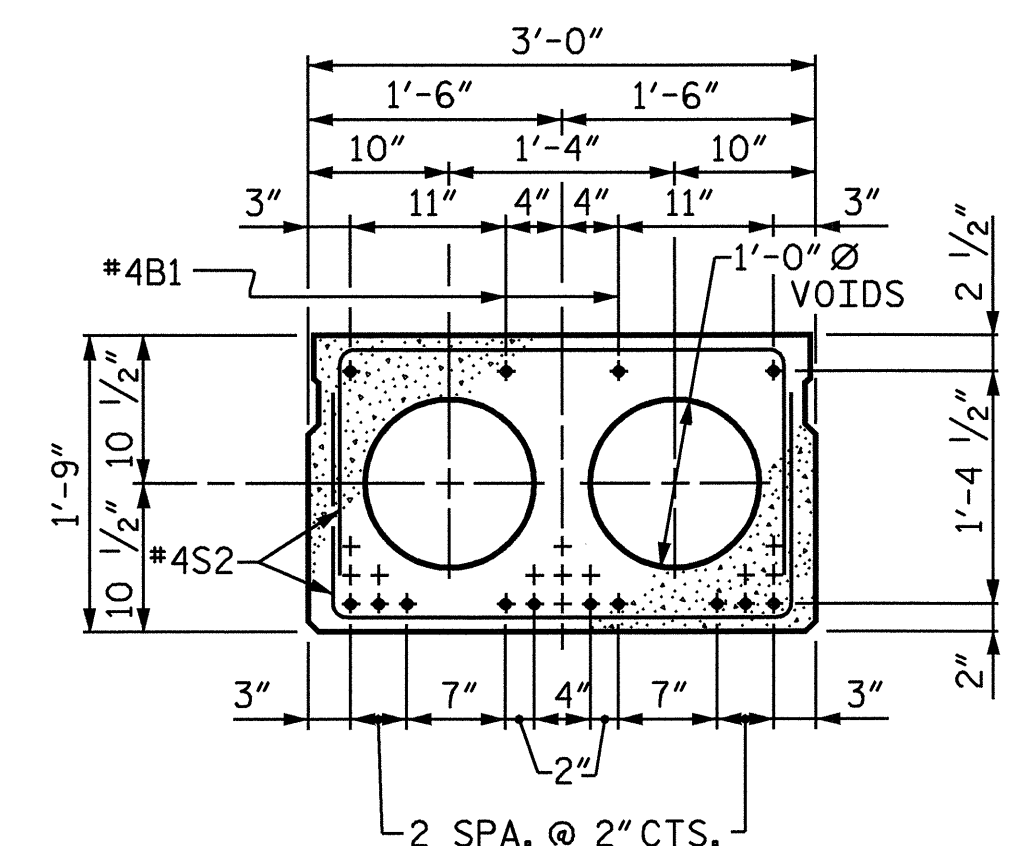

INTERIOR SLAB SECTION SPAN A & C

1/2" Ø LOW RELAXATION STRAND LAYOUT

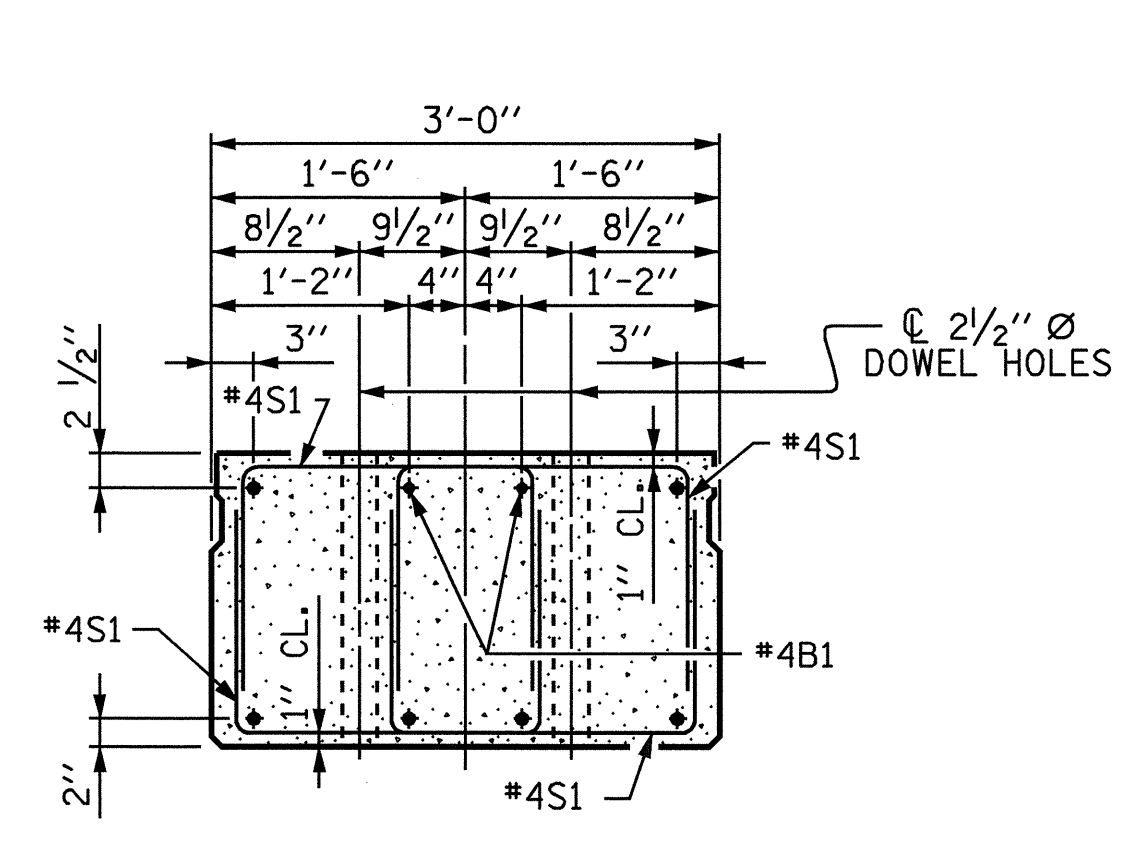

END ELEVATION

SHOWING PLACEMENT OF DOUBLE STIRRUPS AND LOCATION OF DOWEL HOLES. (STRAND LAYOUT NOT SHOWN.) INTERIOR SLAB SECTION SHOWN-EXTERIOR SLAB SECTION SIMILAR EXCEPT SHEAR KEY LOCATION.

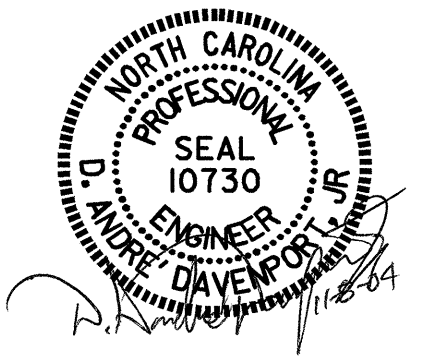

PROJECT NO. B-4320
WAYNE/DUPLIN COUNTY
STATION: 16+47.50 -L-

SHEET 1 OF 5

STATE OF NORTH CAROLINA
DEPARTMENT OF TRANSPORTATION
RALEIGH
3'-0" X 1'-9"
PRESTRESSED CONCRETE
CORED SLAB UNIT

ASSEMBLED BY : D.A. DAVENPORT	DATE : 2-04
CHECKED BY : H.T. BARBOUR	DATE : 3-04
DRAWN BY : WJH 4/89	REV. 8/16/99 RWW/LES
CHECKED BY : FCJ 5/89	REV. 10/17/00 RWW/LES
	REV. 7/10/01 RWW/LES

REVISIONS					SHEET NO. S-4
NO.	BY:	DATE:	NO.	DATE:	
1			3		TOTAL SHEETS 22
2			4		