

PLAN

**NOTES**  
 STIRRUPS IN CAP MAY BE SHIFTED AS NECESSARY TO CLEAR DOWELS.  
 THE LATERAL GUIDE AT EACH END OF THE CAP IS NOT TO BE POURED UNTIL AFTER THE CORED SLAB UNITS ARE IN PLACE.

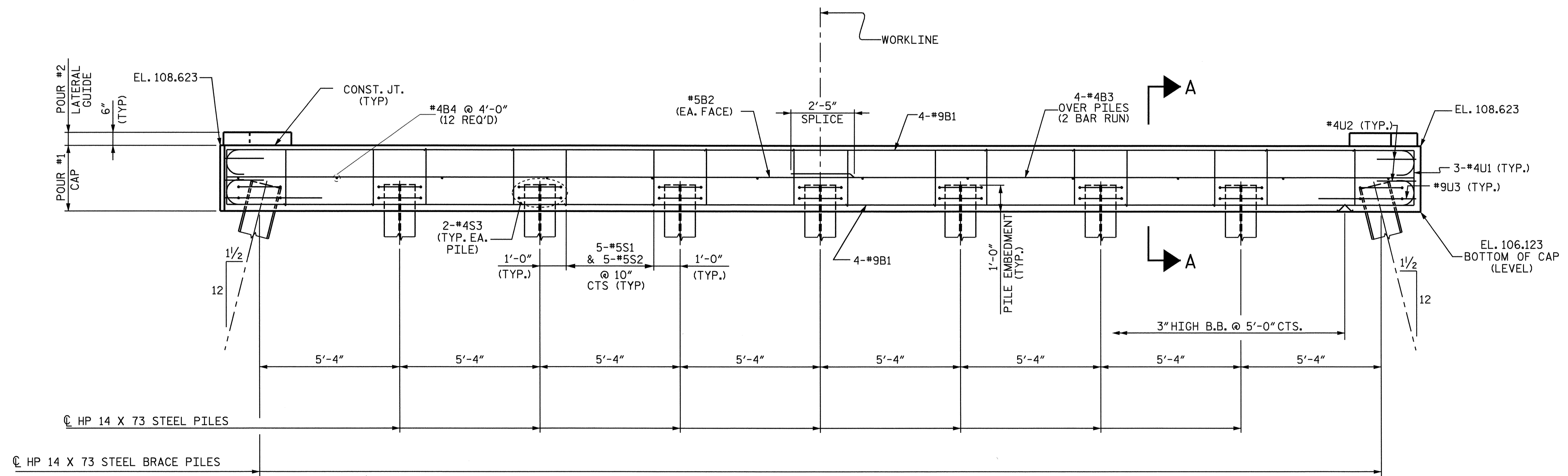

ELEVATION

PROJECT NO. B-4320  
WAYNE/DUPLIN COUNTY  
 STATION: 16+47.50 -L-

SHEET 1 OF 2

STATE OF NORTH CAROLINA  
 DEPARTMENT OF TRANSPORTATION  
 RALEIGH

SUBSTRUCTURE  
 BENT #1

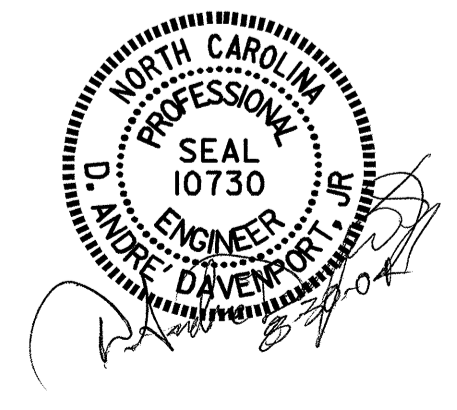

DRAWN BY: ADAM A. COLE DATE: 7/15/04  
 CHECKED BY: SP LAM DATE: 8/04

REVISIONS						SHEET NO.	
NO.	BY:	DATE:	NO.	BY:	DATE:	S-12	
1			3			TOTAL SHEETS	
2			4			22	

30-AUG-2004 11:11  
 w:\squad\jnb4320\acole\Microstation\B4320\_BENT\_01.dgn  
 adoverpor1