

PLAN

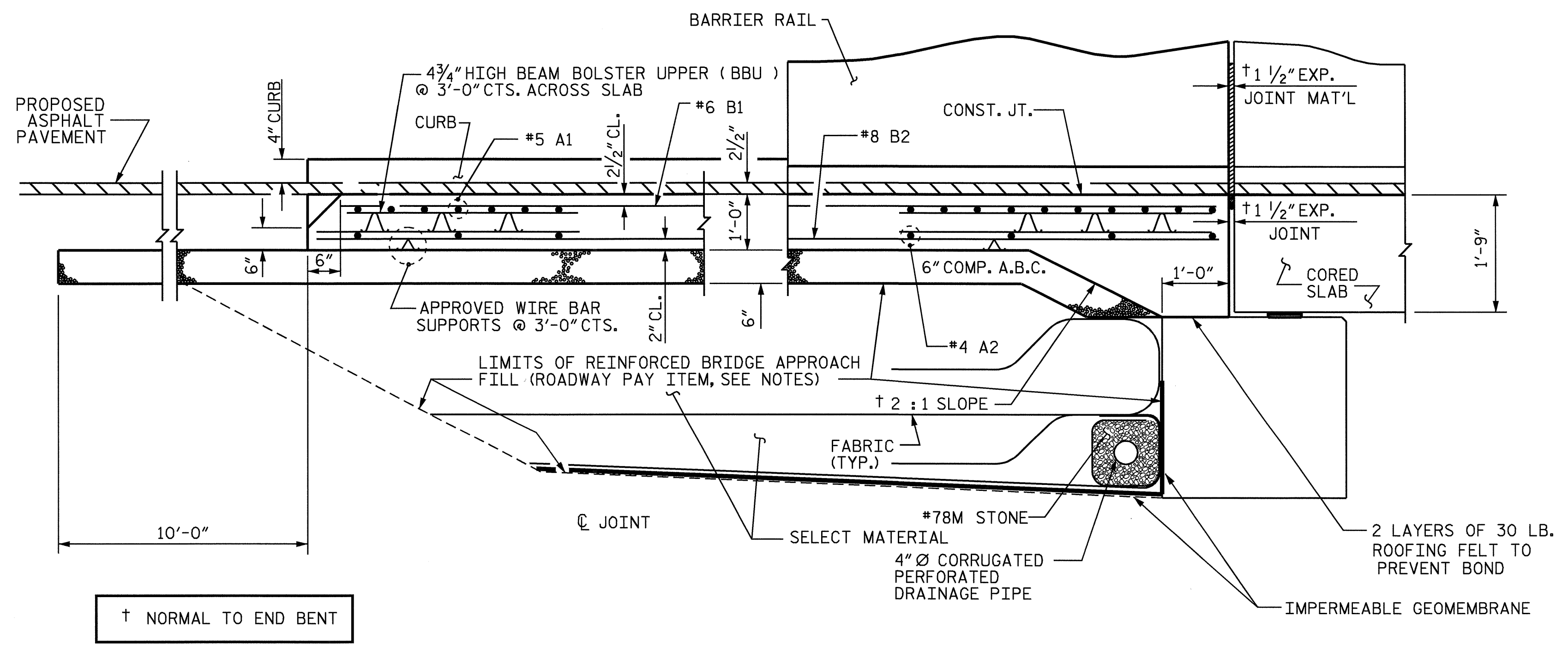

SECTION THRU SLAB

NOTES

THE COST OF THE BARRIER RAIL ON THE APPROACH SLAB SHALL BE INCLUDED IN THE LUMP SUM CONTRACT PRICE BID FOR BRIDGE APPROACH SLABS.

FOR REINFORCED BRIDGE APPROACH FILL INCLUDING FABRIC, IMPERMEABLE GEOMEMBRANE, 4" Ø DRAINAGE PIPE, #78M STONE, AND SELECT MATERIAL, SEE ROADWAY PLANS.

TEMPORARY DRAINAGE AND TEMPORARY BERM AND SLOPE DRAINS WILL BE PAID FOR UNDER THE LUMP SUM PRICE FOR BRIDGE APPROACH SLAB.

AREA BETWEEN THE WINGWALL AND APPROACH SLAB SHALL BE GRADED TO DRAIN THE WATER AWAY FROM THE FILL FACE OF THE BRIDGE AND SHALL BE PAVED. SEE ROADWAY PLANS.

THE 6" COMP. A.B.C. SHALL EXTEND 10'-0" BEYOND THE END OF THE APPROACH SLAB AND 1'-0" OUTSIDE OF EACH EDGE OF SLAB.

THE CONTRACTOR MAY USE 4" TYPE B-25.0B ASPHALT CONCRETE BASE COURSE IN LIEU OF 6" COMP. A.B.C. IF THIS OPTION IS USED, THE BASE COURSE SHALL EXTEND 1'-0" BEYOND THE END OF THE APPROACH SLAB AND THE WIDTH SHALL BE THE SAME AS THAT OF THE APPROACH SLAB.

THE CONTRACTOR MAY USE 5" CLASS "A" CONCRETE BASE IN LIEU OF 6" COMP. A.B.C. IF THIS OPTION IS USED, THE CONCRETE BASE SHALL EXTEND 1'-0" BEYOND THE END OF THE APPROACH SLAB AND THE WIDTH SHALL BE THE SAME AS THAT OF THE APPROACH SLAB. THE CONCRETE SHALL BE FINISHED TO A SMOOTH SURFACE AND A LAYER OF 30 LB ROOFING FELT SHALL BE PLACED BETWEEN THE CONCRETE BASE AND THE APPROACH SLAB TO PREVENT BOND. THE APPROACH SLAB SHALL NOT BE CAST UNTIL THE CONCRETE BASE HAS REACHED AN AGE OF THREE CURING DAYS.

FOR JOINT DETAILS, SEE "PRESTRESSED CONCRETE CORED SLAB UNIT" SHEETS.

THE JOINT AT THE END BENT SHALL BE SEALED AS SOON AS PRACTICAL AFTER THE CONSTRUCTION OF THE APPROACH SLABS.

APPROACH SLAB GROOVING IS NOT REQUIRED.

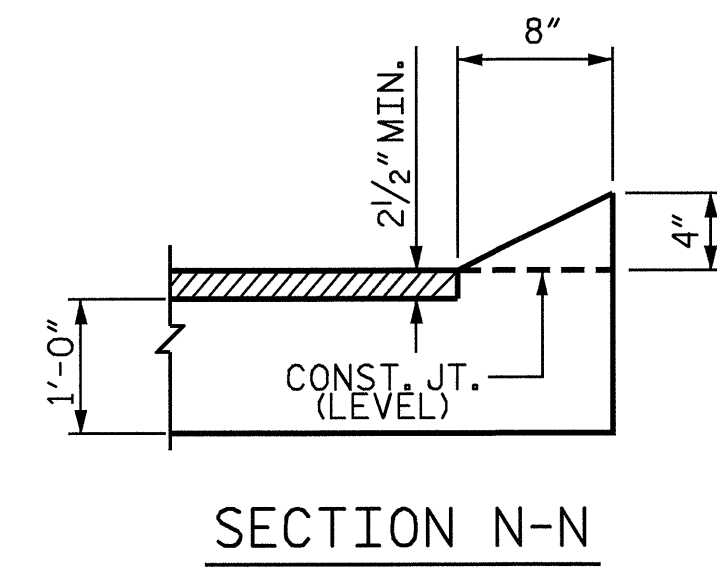

SECTION N-N

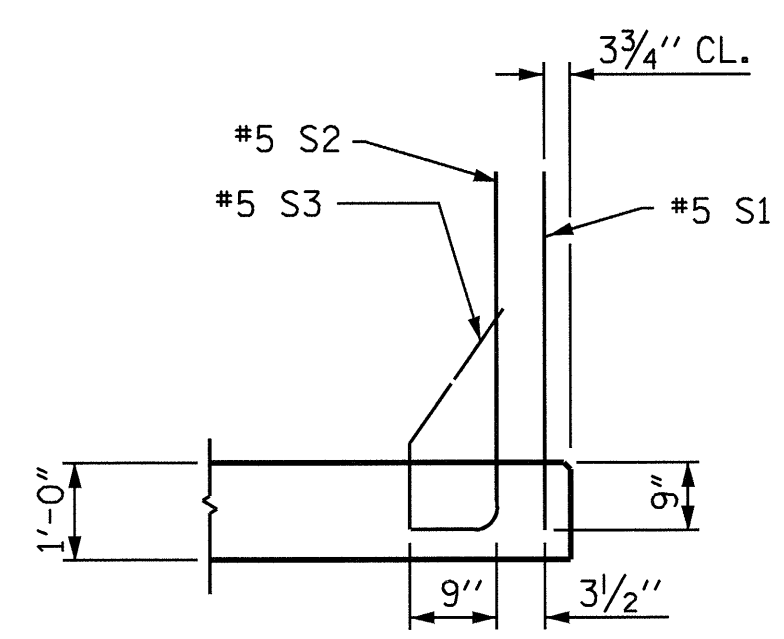

SECTION K-K

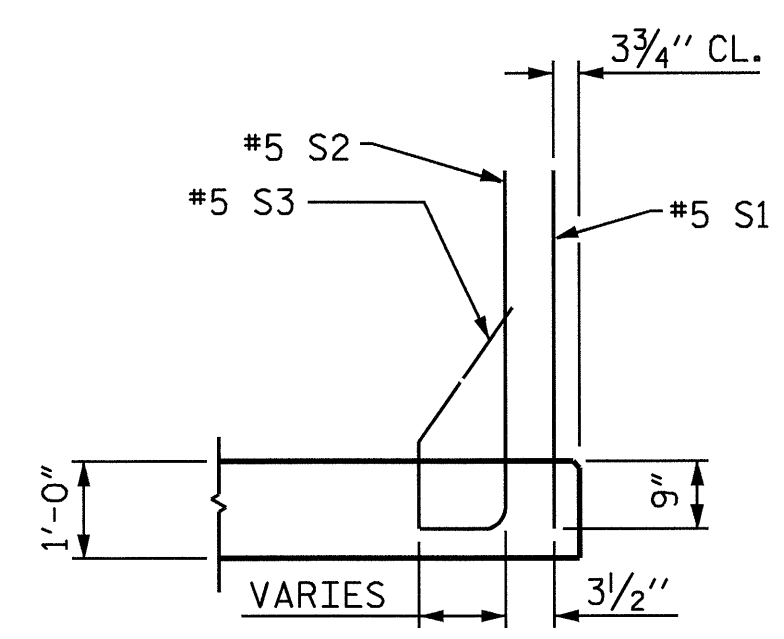

SECTION L-L

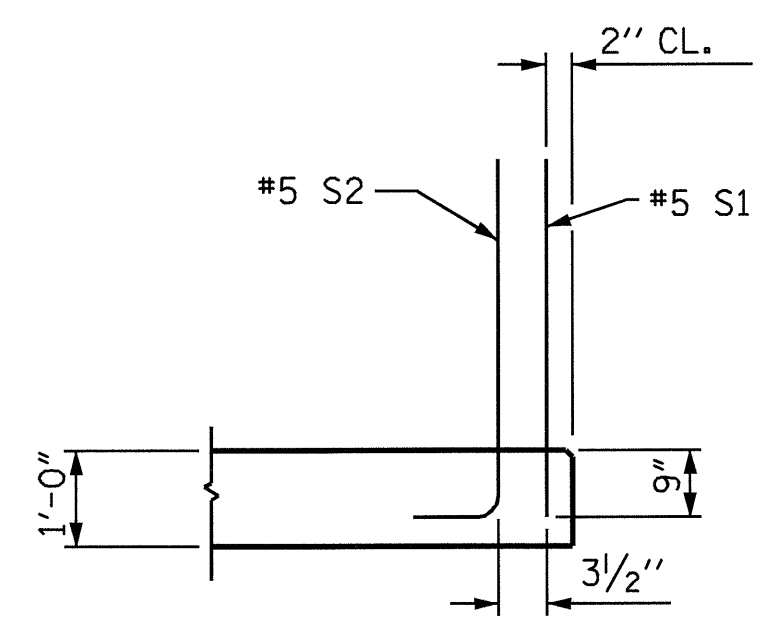

SECTION M-M

BILL OF MATERIAL					
FOR ONE APPROACH SLAB (2 REQ'D)					
BAR	NO.	SIZE	TYPE	LENGTH	WEIGHT
*A1	49	#5	STR	44'-4"	2266
A2	98	#4	STR	23'-9"	1555
*B1	89	#6	STR	24'-2"	3231
B2	89	#8	STR	24'-8"	5862
*B3	14	#5	STR	11'-8"	170
*B4	2	#5	1	6'-7"	14
*S1	48	#5	STR	3'-3"	163
*S2	48	#5	2	4'-1"	204
*S3	20	#5	3	2'-3"	47
REINFORCING STEEL					LBS. 7417
*EPOXY COATED REINFORCING STEEL					LBS. 6095
CLASS AA CONCRETE BREAKDOWN					
SLAB					C. Y. 27.3
RAIL & CURB					C. Y. 1.8
CLASS AA CONCRETE					C. Y. 29.1

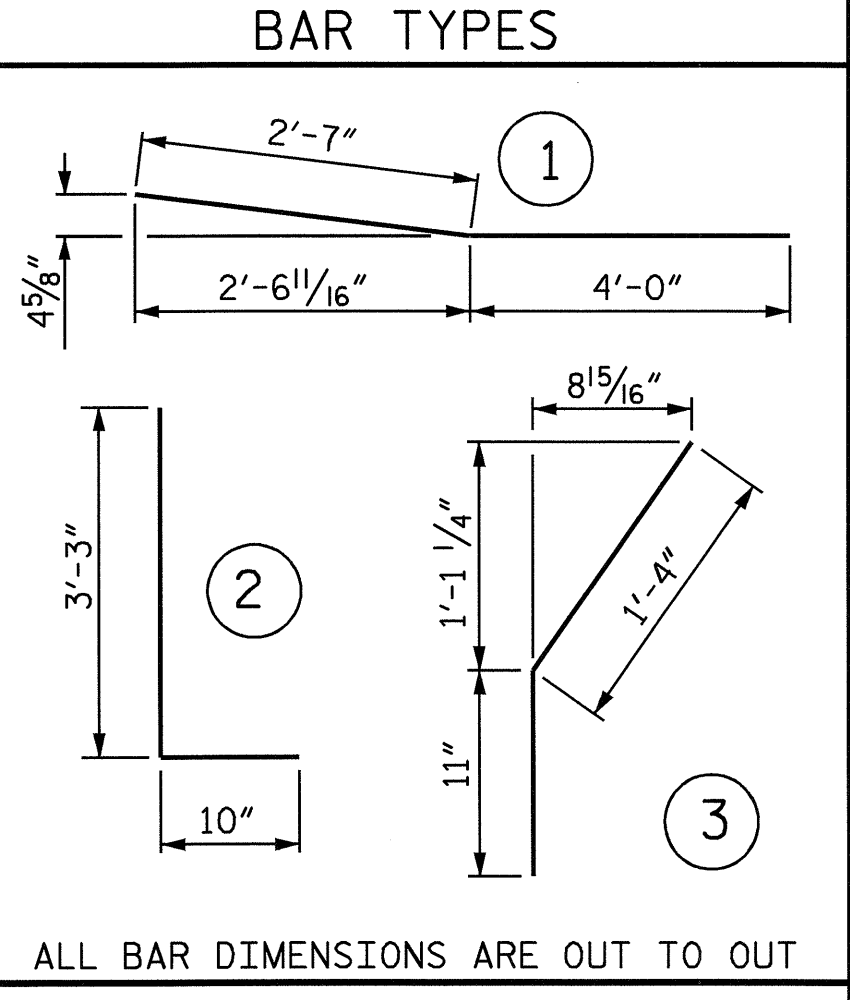

ALL BAR DIMENSIONS ARE OUT TO OUT

PROJECT NO. B-3906
 WAKE COUNTY
 STATION: 28+52.50 -L-

SHEET 1 OF 3

STATE OF NORTH CAROLINA
 DEPARTMENT OF TRANSPORTATION
 RALEIGH
 STANDARD
 BRIDGE APPROACH SLAB
 FOR PRESTRESSED CONCRETE
 CORED SLAB WITH
 BARRIER RAIL

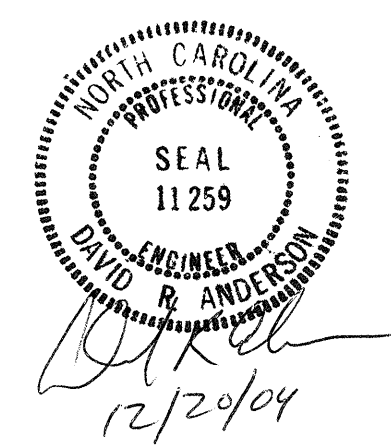

ASSEMBLED BY: N. Q. TRAN	DATE: 6/3/04
CHECKED BY: S. M. RASHIDI	DATE: 11/3/04
DRAWN BY: LES 8/01	REV. 10/17/00 RWW/LES
CHECKED BY: RDR 8/01	REV. 7/10/01 LES/RDR
	REV. 5/7/03 RWW/JTE

REVISIONS						SHEET NO.	
NO.	BY:	DATE:	NO.	BY:	DATE:	S-36	
1			3			TOTAL SHEETS	
2			4			38	