

TYPICAL SECTION

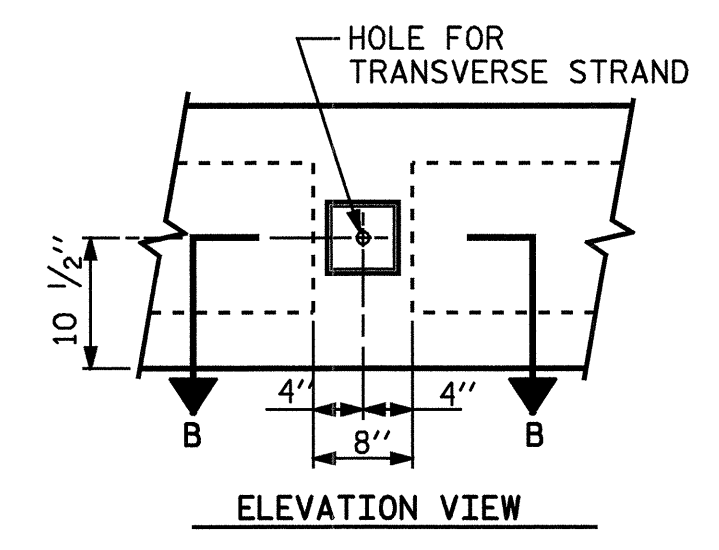

ELEVATION VIEW

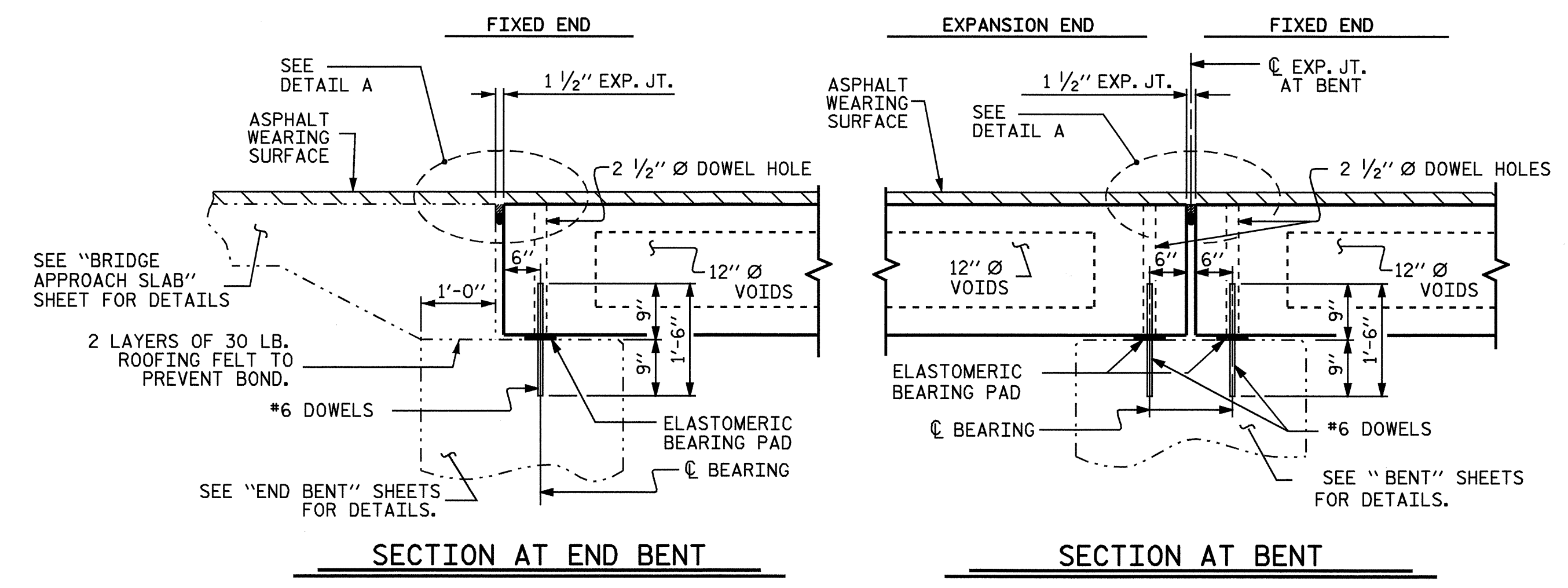
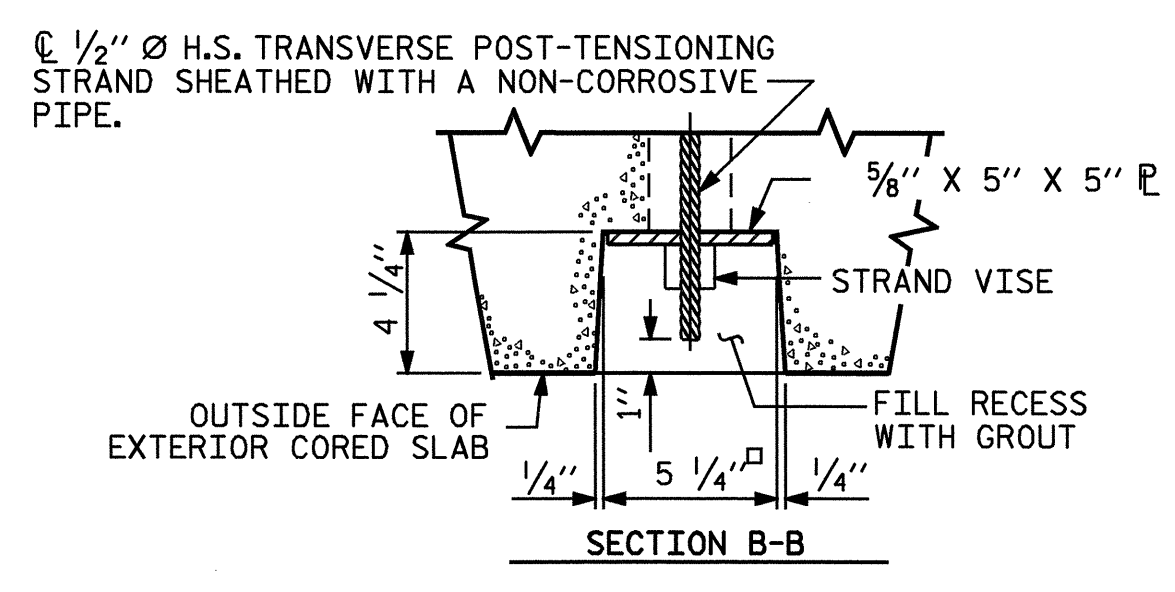

SECTION B-B

GROUTED RECESS AT END OF POST-TENSIONED STRAND CORED SLABS

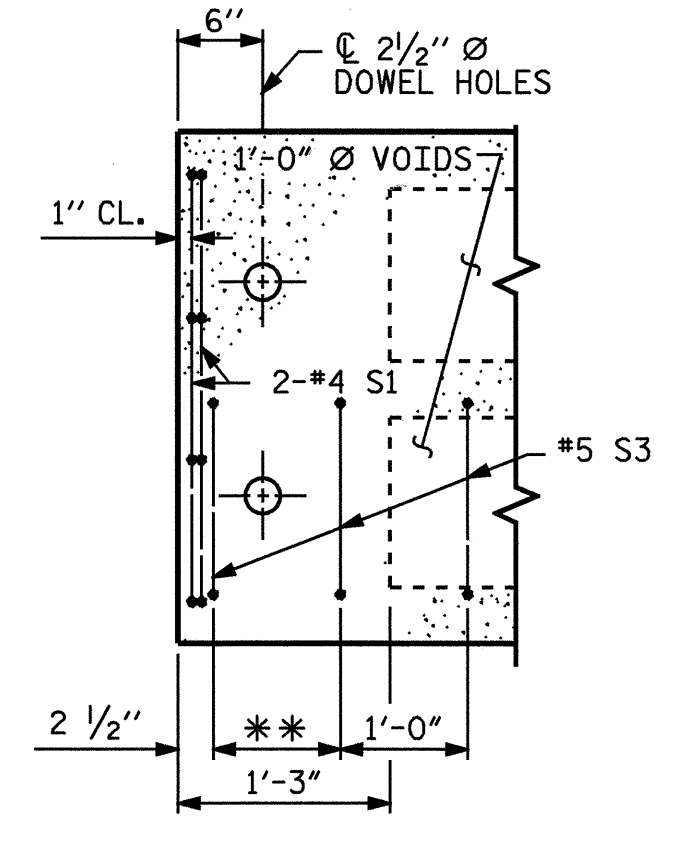

PART PLAN-EXTERIOR SECTION

NOTE: EXTERIOR SECTION SHOWN-INTERIOR SECTION SIMILAR EXCEPT OMIT S3 BARS.
** SEE PLAN OF SPANS

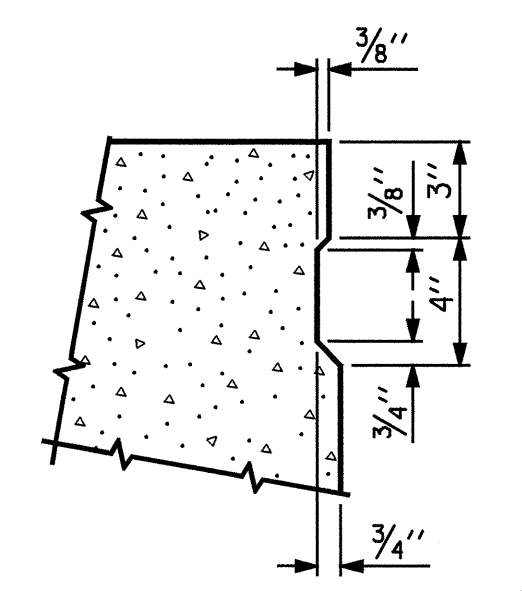

SHEAR KEY DETAIL

NOTE: OMIT SHEAR KEY ON OUTSIDE FACE OF EXTERIOR CORED SLABS.

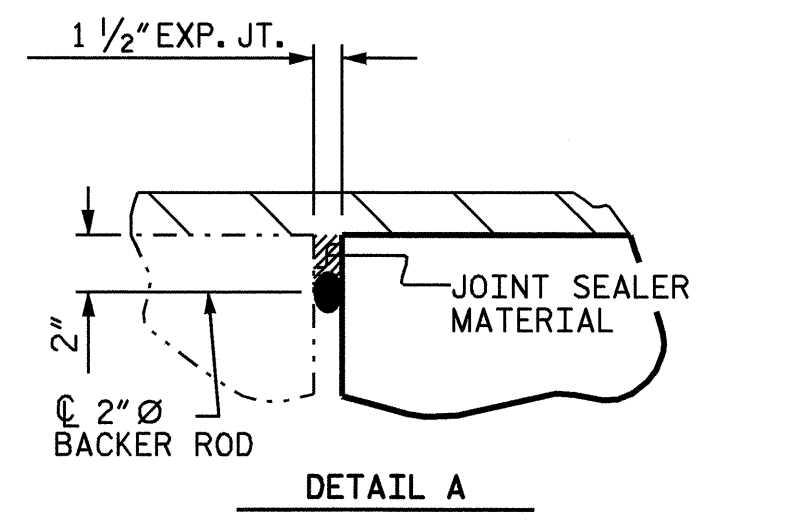

DETAIL A

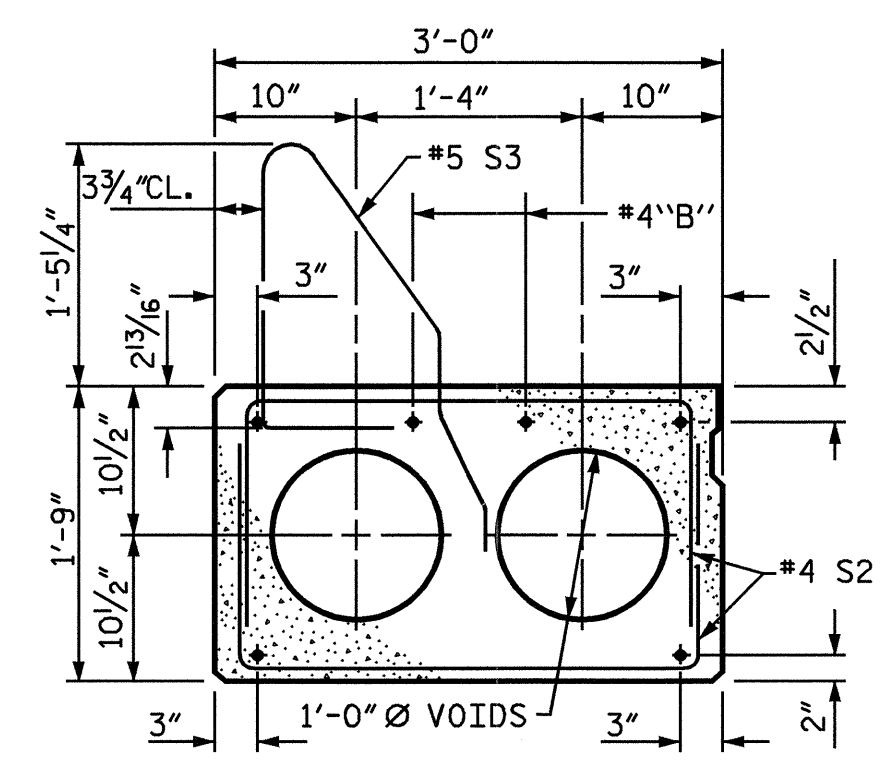

EXTERIOR SLAB SECTION

(FOR PRESTRESSED STRAND LAYOUT, SEE INTERIOR SLAB SECTION.)

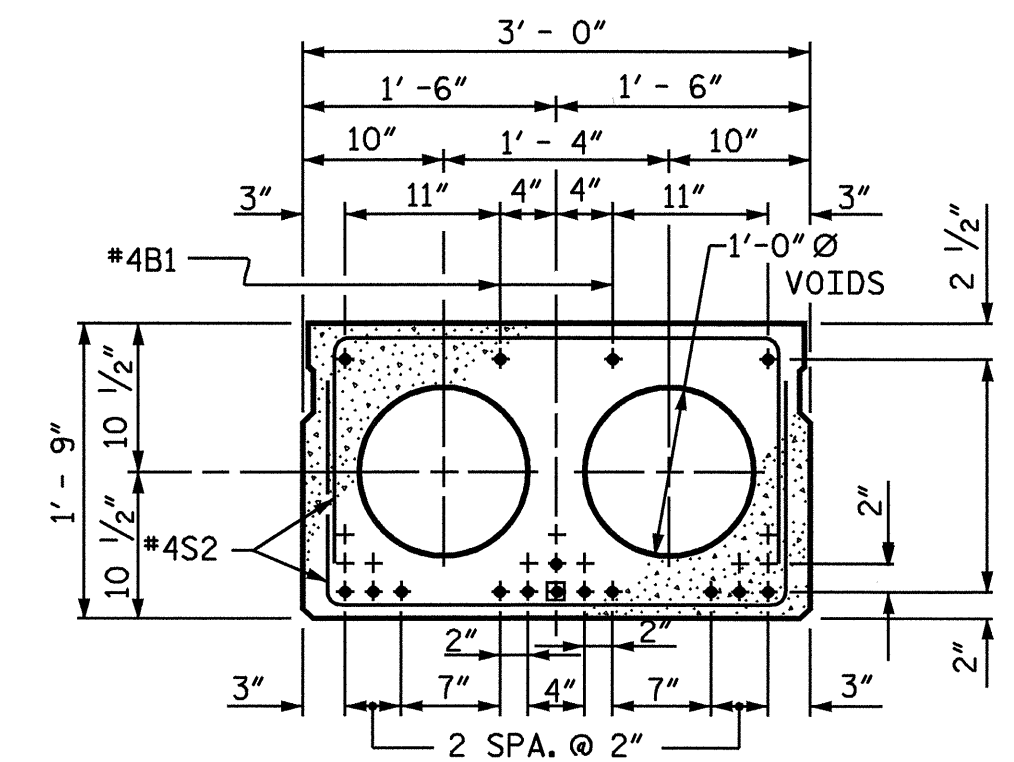

INTERIOR SLAB SECTION
1/2" Ø LOW RELAXATION STRAND LAYOUT

SPANS A & C

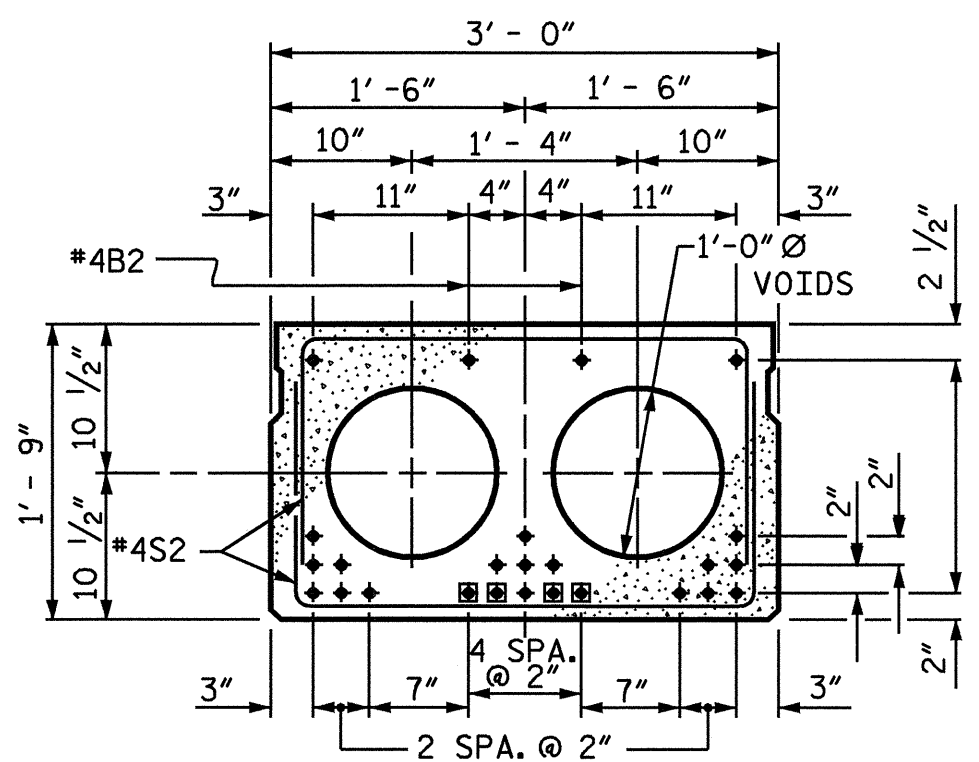

INTERIOR SLAB SECTION
1/2" Ø LOW RELAXATION STRAND LAYOUT

SPAN B

■ BOND SHALL BE BROKEN ON THESE STRANDS FOR A DISTANCE OF 4'-0" FROM END OF CORED SLAB UNIT. SEE STANDARD SPECIFICATIONS, ARTICLE 1078-7

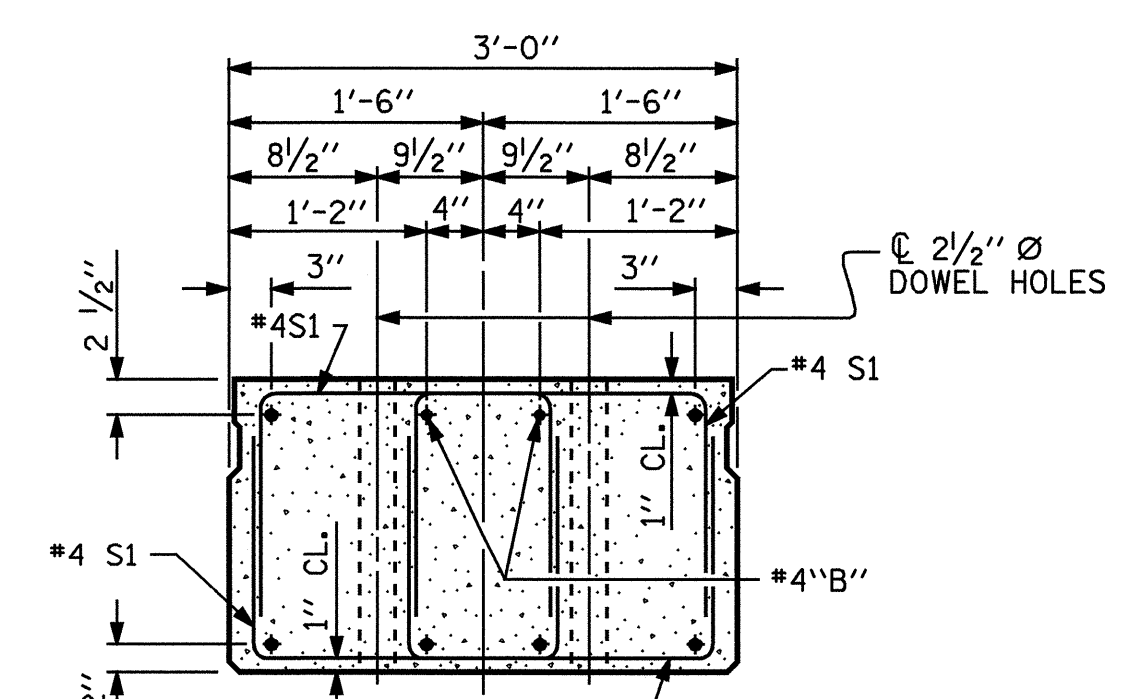

END ELEVATION

SHOWING PLACEMENT OF DOUBLE STIRRUPS AND LOCATION OF DOWEL HOLES. (STRAND LAYOUT NOT SHOWN.) INTERIOR SLAB SECTION SHOWN-EXTERIOR SLAB SECTION SIMILAR EXCEPT SHEAR KEY LOCATION.

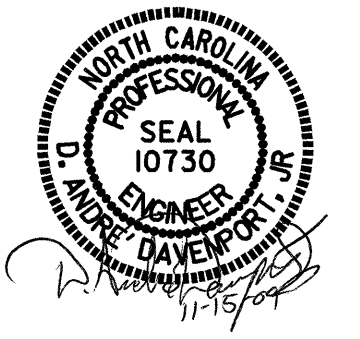

PROJECT NO. B-4515
FRANKLIN COUNTY
STATION: 15+37.00-L-

SHEET 1 OF 7

STATE OF NORTH CAROLINA
DEPARTMENT OF TRANSPORTATION
RALEIGH

STANDARD
3'-0" X 1'-9"
PRESTRESSED CONCRETE
CORED SLAB UNIT

REVISIONS						SHEET NO.
NO.	BY:	DATE:	NO.	BY:	DATE:	S-4
1			3			TOTAL SHEETS
2			4			24

ASSEMBLED BY : B.N. GRADY/AAC	DATE : 12/02
CHECKED BY : H.T. BARBOUR	DATE : 9/04
DRAWN BY : WJH 4/89	REV. 8/16/99 RWW/LES
CHECKED BY : FCJ 5/89	REV. 10/17/00 RWW/LES
	REV. 7/10/01 RWW/LES