

ARC OFFSET - RIGHT EDGE

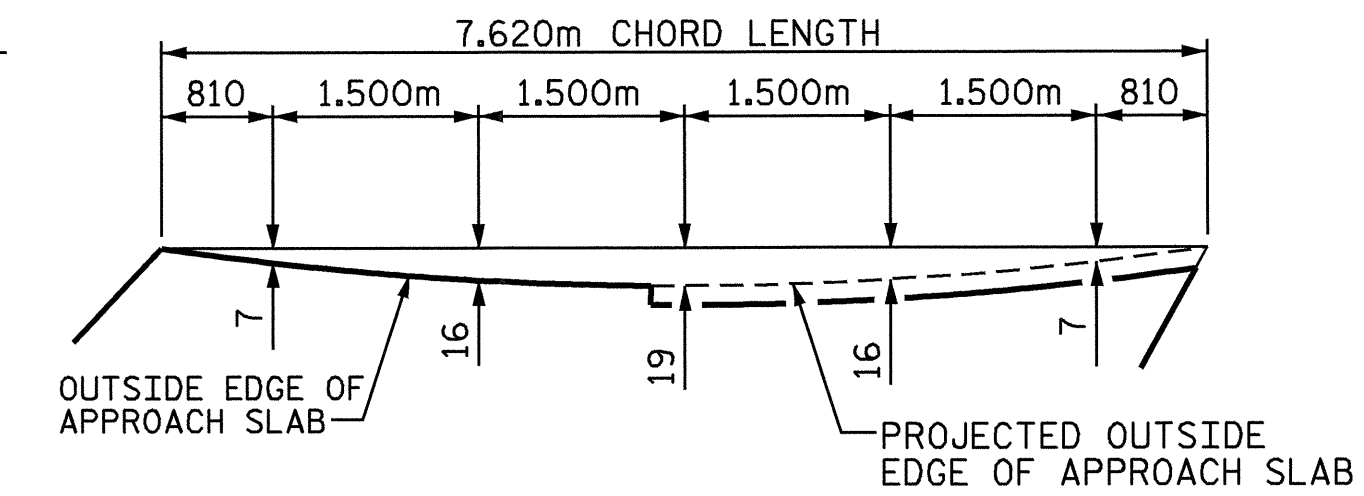

ARC OFFSET - LEFT EDGE

NOTES

- ALL "A" BARS ARE PLACED PERPENDICULAR TO SHORT CHORD.
- ALL "B" BARS ARE PLACED PARALLEL TO SHORT CHORD.
- SEE SHEET 3 OF 6 FOR BARRIER RAIL REINFORCING STEEL AND DETAILS.
- ** MEASURED RADIALLY.

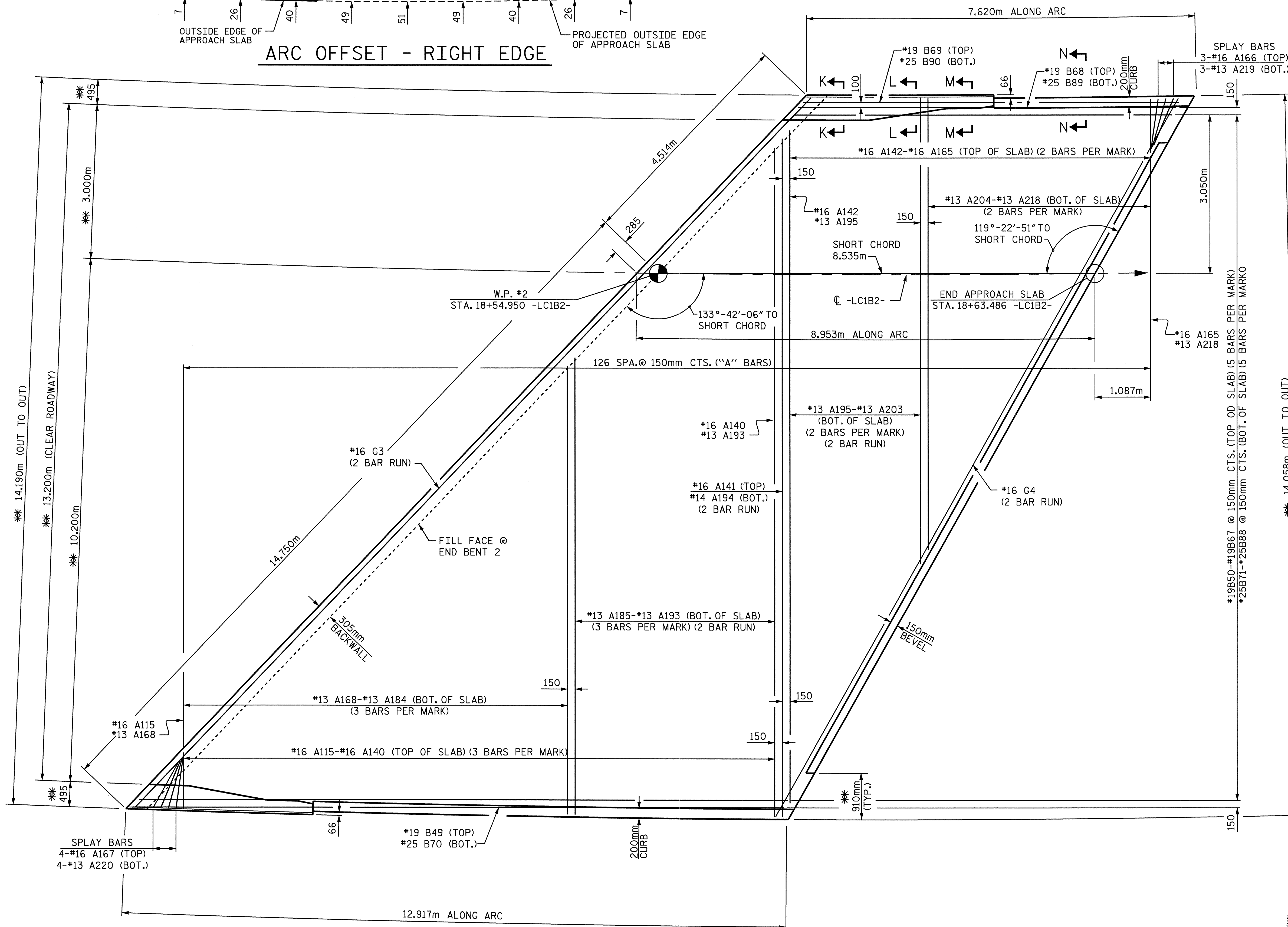

PLAN

DRAWN BY : A.S. CALLAWAY DATE : 5/12/04
 CHECKED BY : P.C. BREWER DATE : 10/11/04

20-DEC-2004 16:41
 W:\Squad\l\0977a\str2\scallaway\R0977A.sd.AS.02.dgn
 lsu+ton

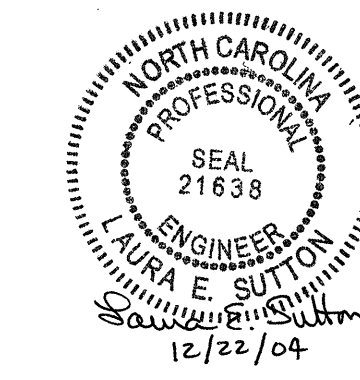

PROJECT NO. R-0977A
 CHEROKEE COUNTY
 STATION: 18+31.299-LC1B2-

SHEET 2 OF 6

STATE OF NORTH CAROLINA DEPARTMENT OF TRANSPORTATION RALEIGH					
BRIDGE APPROACH SLAB FOR FLEXIBLE PAVEMENT WITH BARRIER RAIL					
(AT END BENT 2)					
REVISIONS					
NO.	BY:	DATE:	NO.	BY:	DATE:
1			3		
2			4		
					SHEET NO. S-74
					TOTAL SHEETS 230

STR. #2