

**PLAN OF INTERIOR CORED SLAB UNITS**  
(TYP. SPANS A, B, & C)

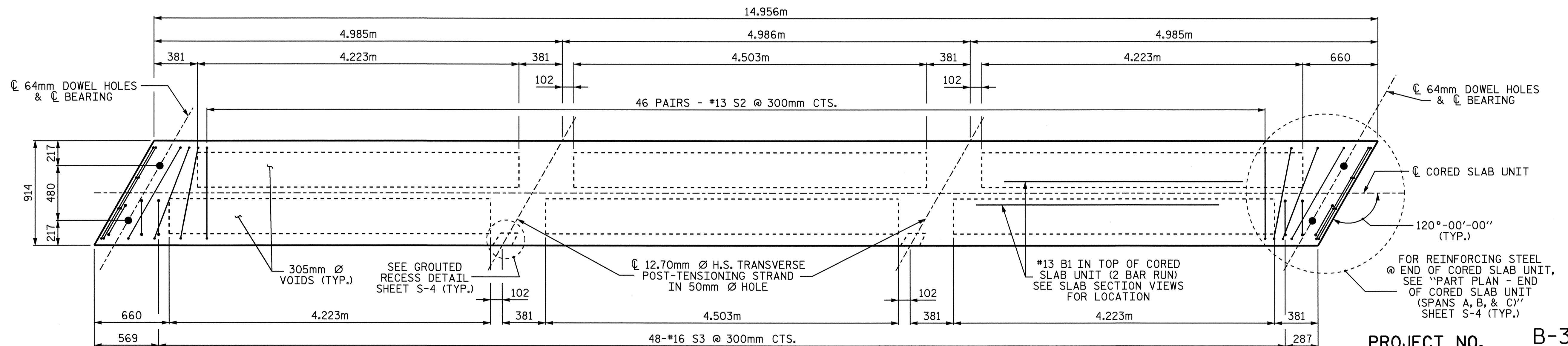

**PLAN OF EXTERIOR CORED SLAB UNITS**  
(TYP. SPANS A, B, & C)

PROJECT NO. B-3266  
WILKES COUNTY  
 STATION: 12+48.000 -L-

SHEET 1 OF 2

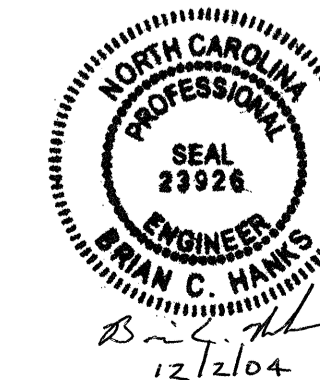

STATE OF NORTH CAROLINA  
 DEPARTMENT OF TRANSPORTATION  
 RALEIGH  
 SUPERSTRUCTURE  
 PLAN OF CORED SLAB  
 UNIT DETAILS

REVISIONS						SHEET NO.
NO.	BY:	DATE:	NO.	BY:	DATE:	S-9
1			3			TOTAL SHEETS
2			4			26

DRAWN BY: William J. Parker DATE: 01/15/04  
 CHECKED BY: A.B. NAIK DATE: 4/27/04