

NOTES

STIRRUPS IN CAP MAY BE SHIFTED AS NECESSARY TO CLEAR ANCHOR BOLTS.
THE LATERAL GUIDE AT EACH END OF THE CAP IS NOT TO BE POURED UNTIL AFTER THE CORED SLAB UNITS ARE IN PLACE.

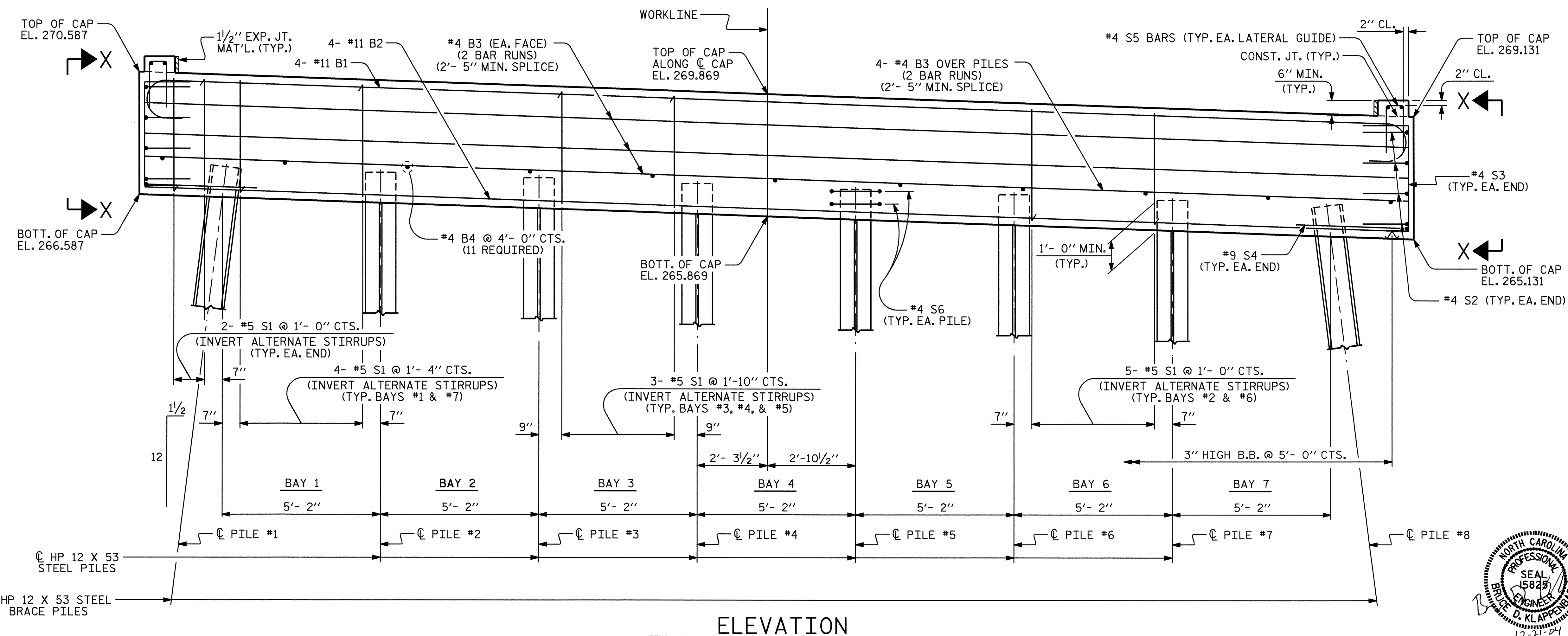
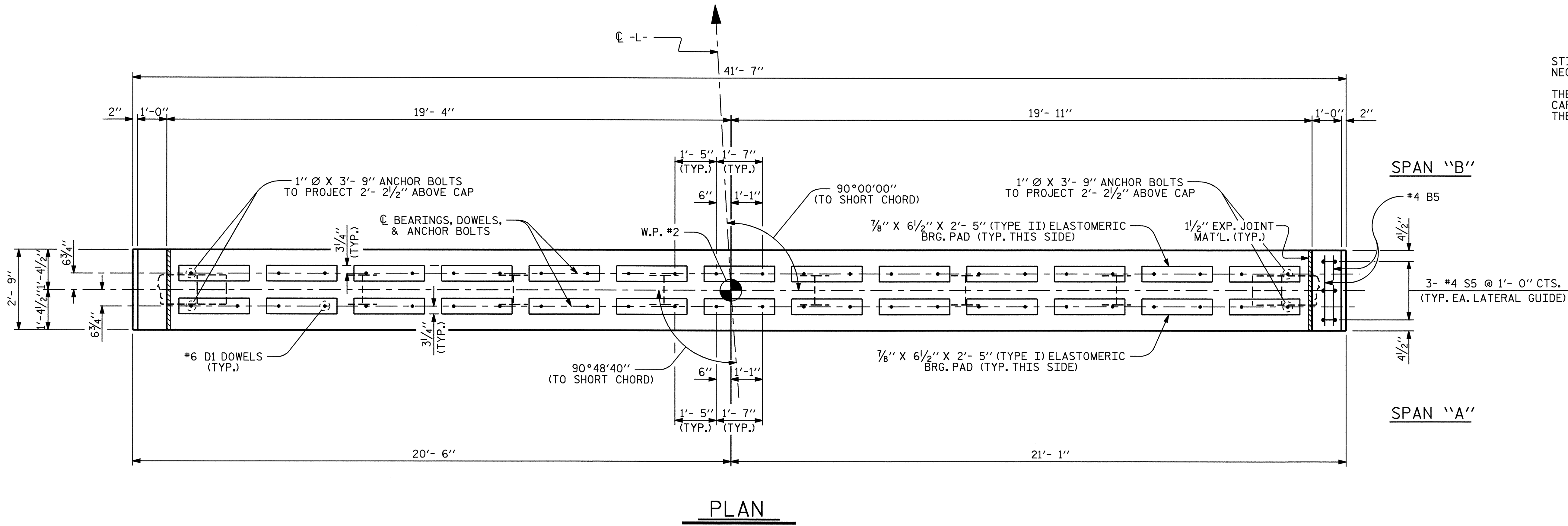

PILE ELEVATIONS	
PILE #1	EL. 267.471
PILE #2	EL. 267.328
PILE #3	EL. 267.147
PILE #4	EL. 266.967
PILE #5	EL. 266.786
PILE #6	EL. 266.605
PILE #7	EL. 266.424
PILE #8	EL. 266.248

PROJECT NO. B-3703
WAKE COUNTY
STATION: 18+17.85 -L-

SHEET 1 OF 2

STATE OF NORTH CAROLINA
DEPARTMENT OF TRANSPORTATION
RALEIGH

SUBSTRUCTURE
BENT #1

REVISIONS						SHEET NO.	
NO.	BY:	DATE:	NO.	BY:	DATE:	S-17	
1			3			TOTAL SHEETS 27	
2			4				

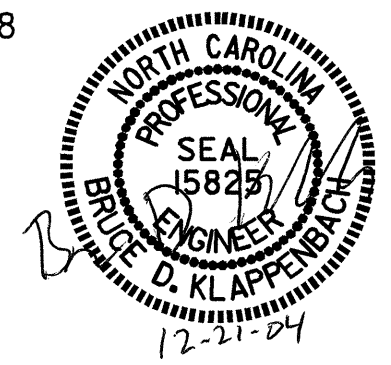

DRAWN BY : D. A. GLADDEN DATE : 10-18-04
CHECKED BY : M. G. SHAIKH DATE : 10-27-04

20-DEC-2004 09:00
W:\squad\B3703\dgladden\MICROS\B-3703\B.DGN
dgladden