

6/15/03

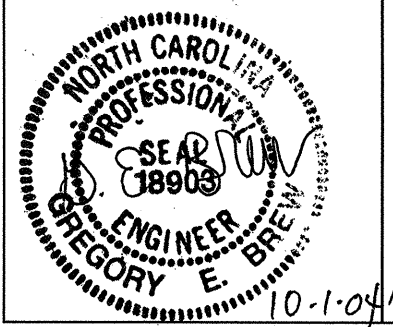

PROJECT REFERENCE NO. B-3376	SHEET NO. 2-B
ROADWAY DESIGN ENGINEER	HYDRAULICS ENGINEER
	
10-1-04	10/1/04

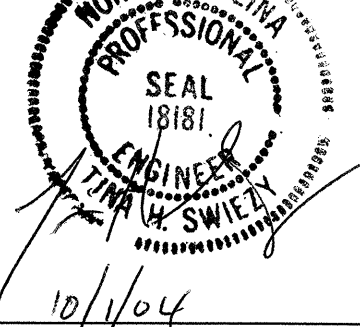
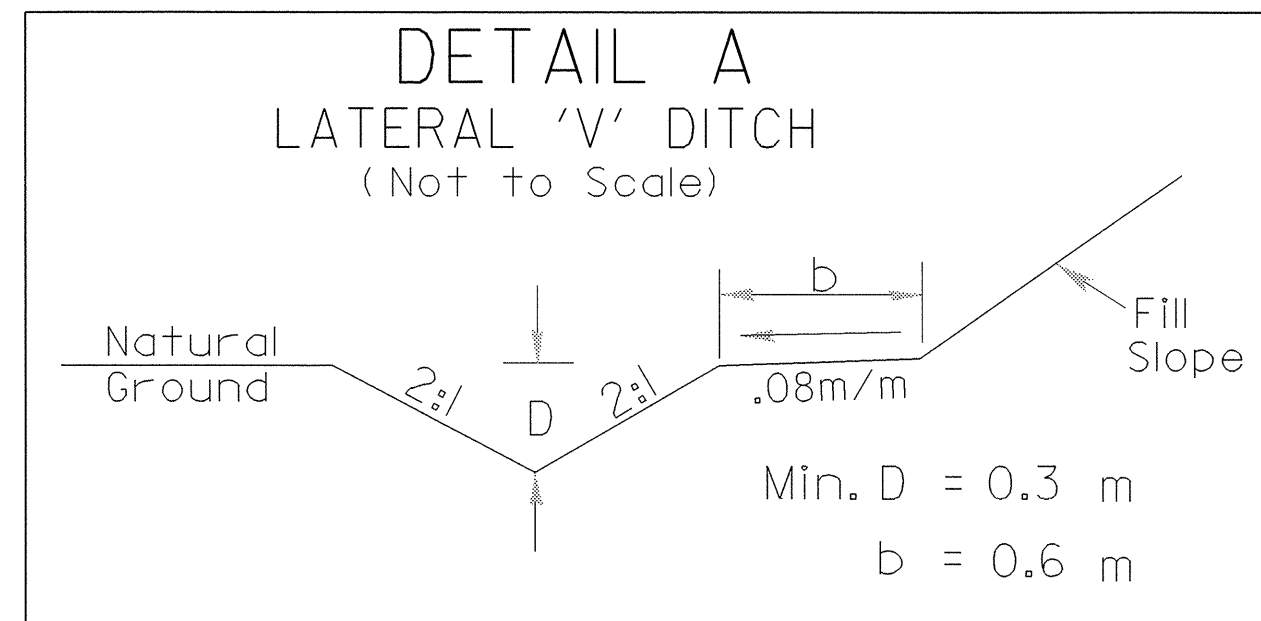

-L- STA. 13+17.473 - 13+47.473 RT
ESTIMATED DDE = 12 CM

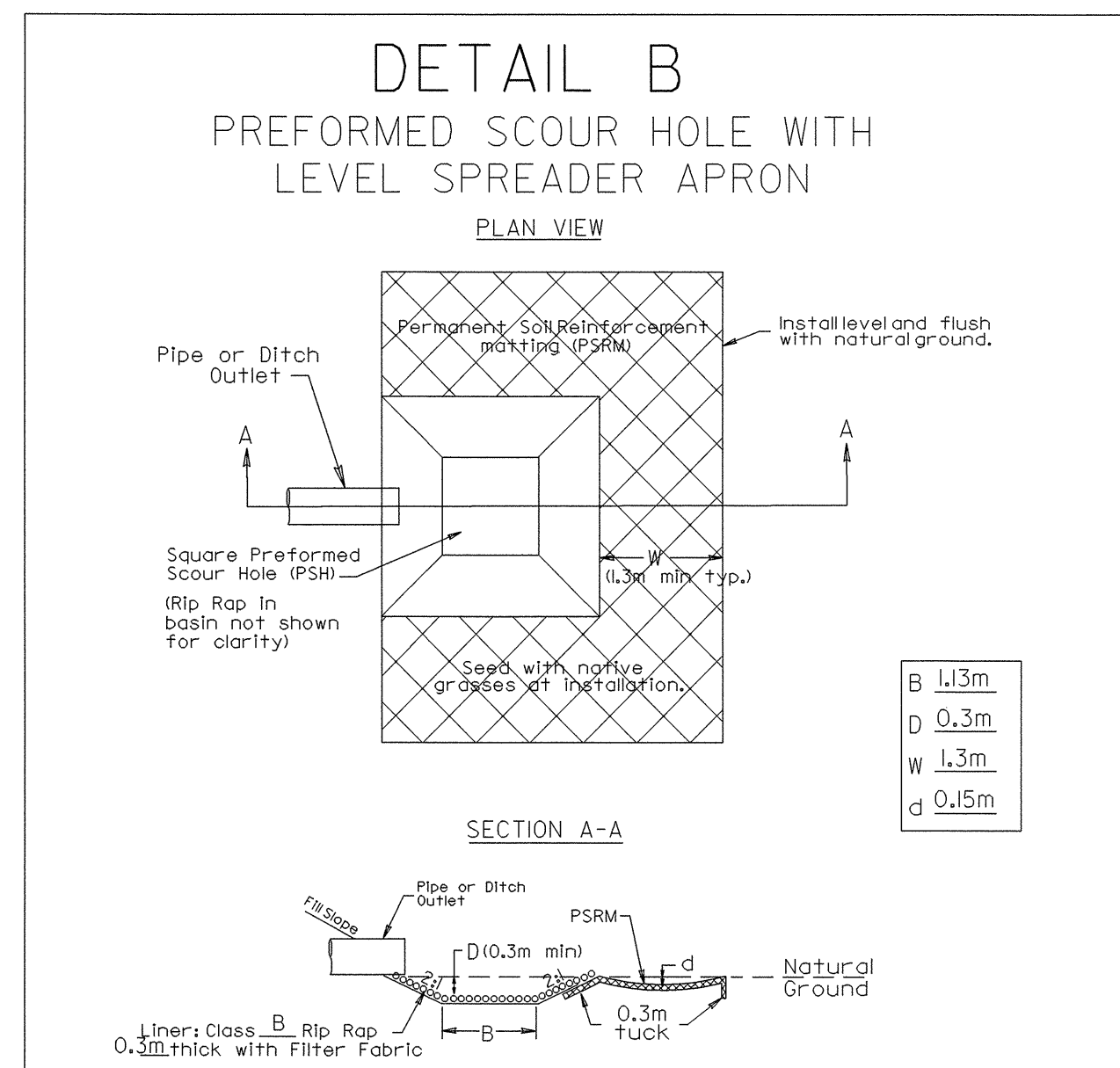

-L- STA. 13+15 RT

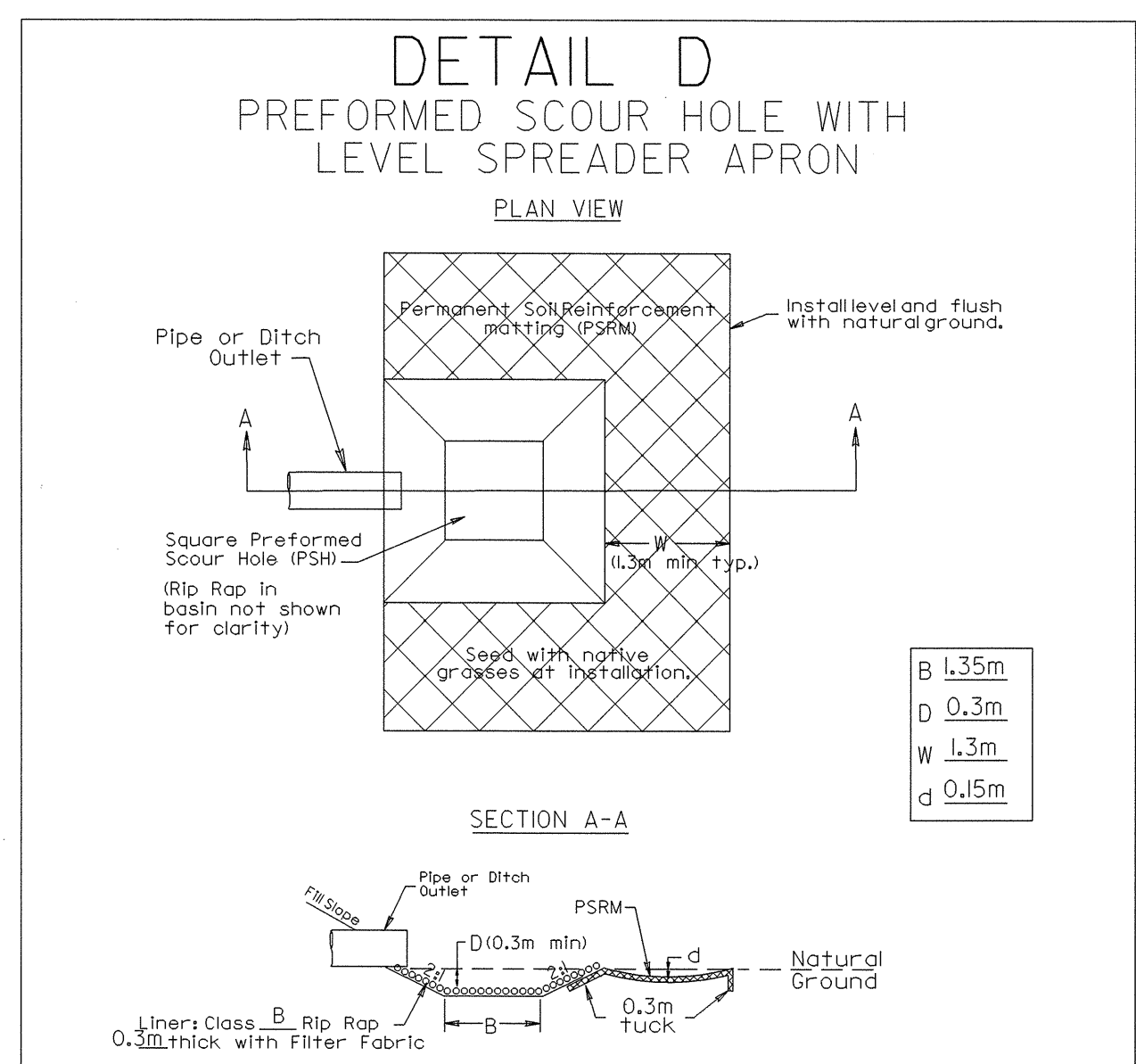

-L- STA. 12+24 LT
-L- STA. 13+09 LT
-DET- STA. 12+52 LT (TEMP)

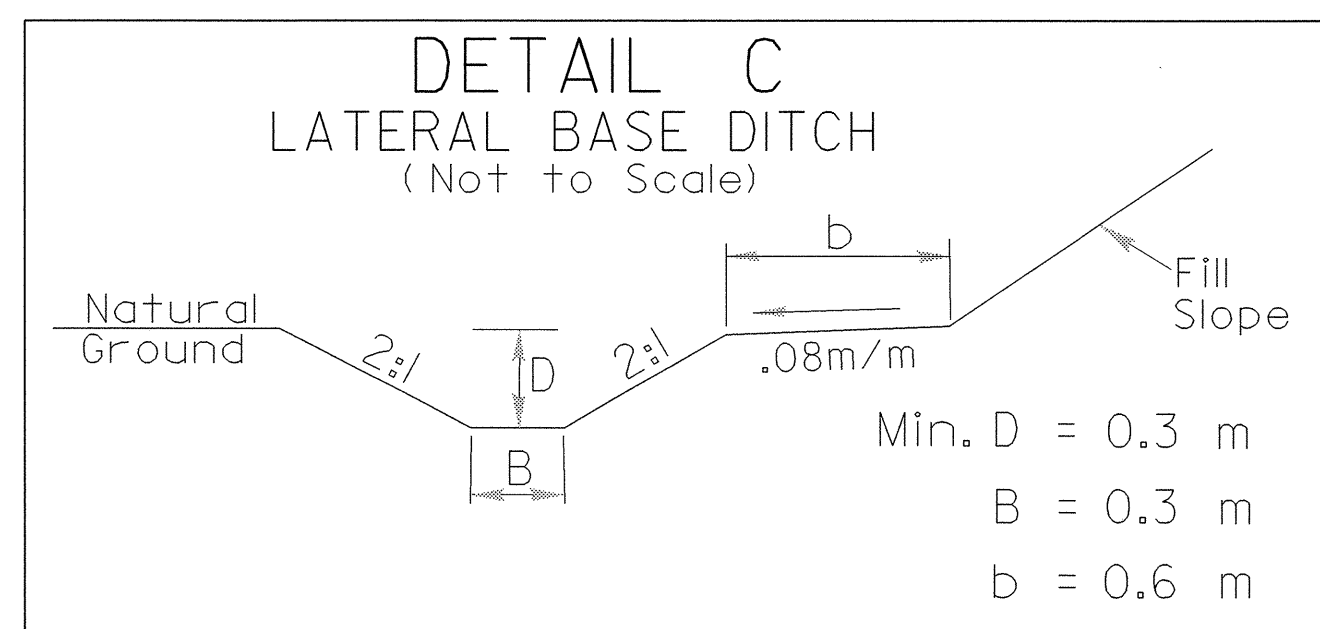

-L- STA. 13+07.473 - 13+27.473 LT
ESTIMATED DDE = 122 CM
-DET- STA. 12+48 - 12+55 LT
ESTIMATED DDE (DET) = 3 CM

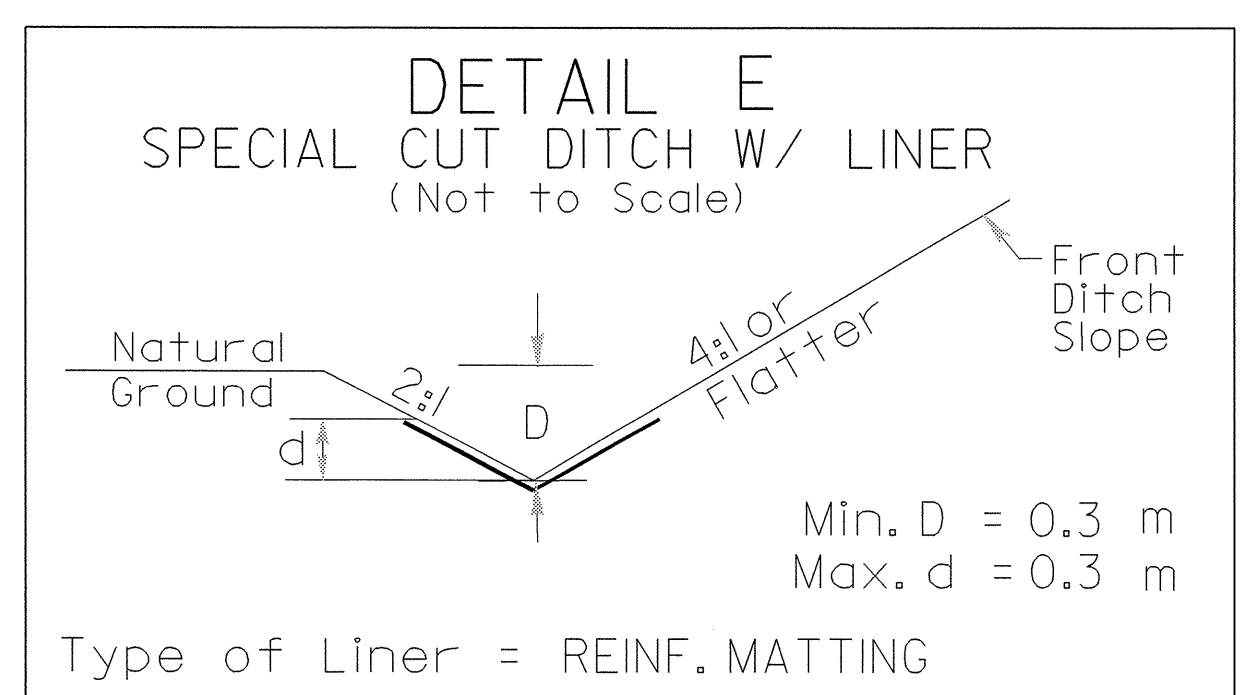

-DET- STA. 10+96.371 - 11+42.940 RT
-L- STA. 11+40 - 12+06 LT

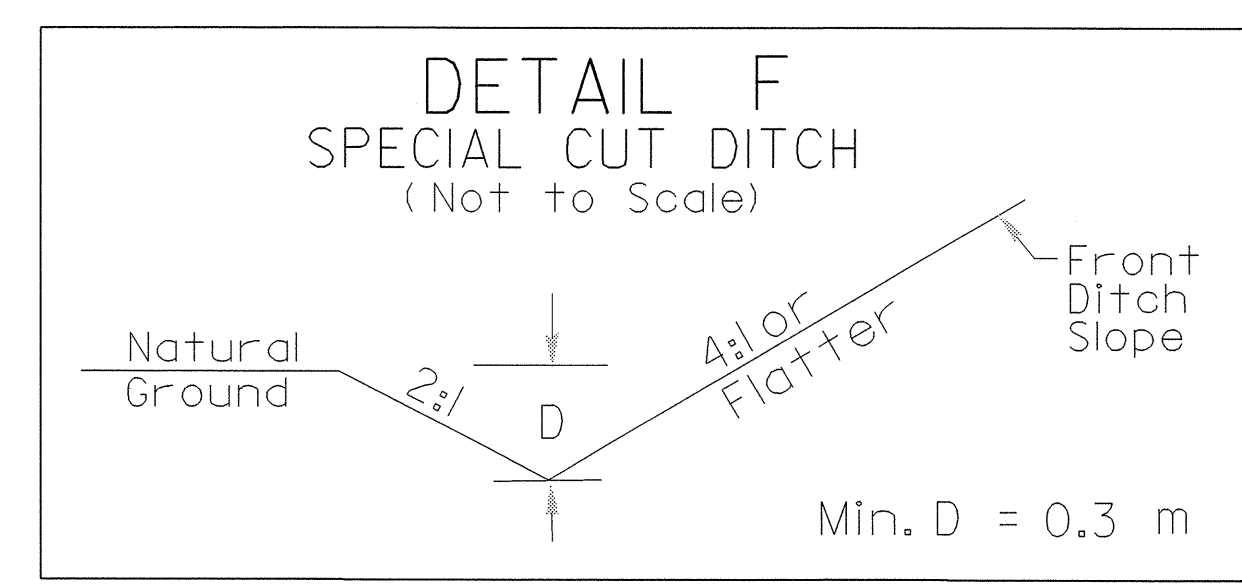

-L- STA. 10+60 - 10+80 LT & RT
-L- STA. 14+20 - 14+40 LT & RT
-DET- STA. 14+07 - 14+47 LT (TEMP)
-DRIVE 2- STA. 10+08 - 10+14 RT
NOTE: -L- STA. 10+60 - 10+80 RT. USE 3:1 FRONT DITCH SLOPE

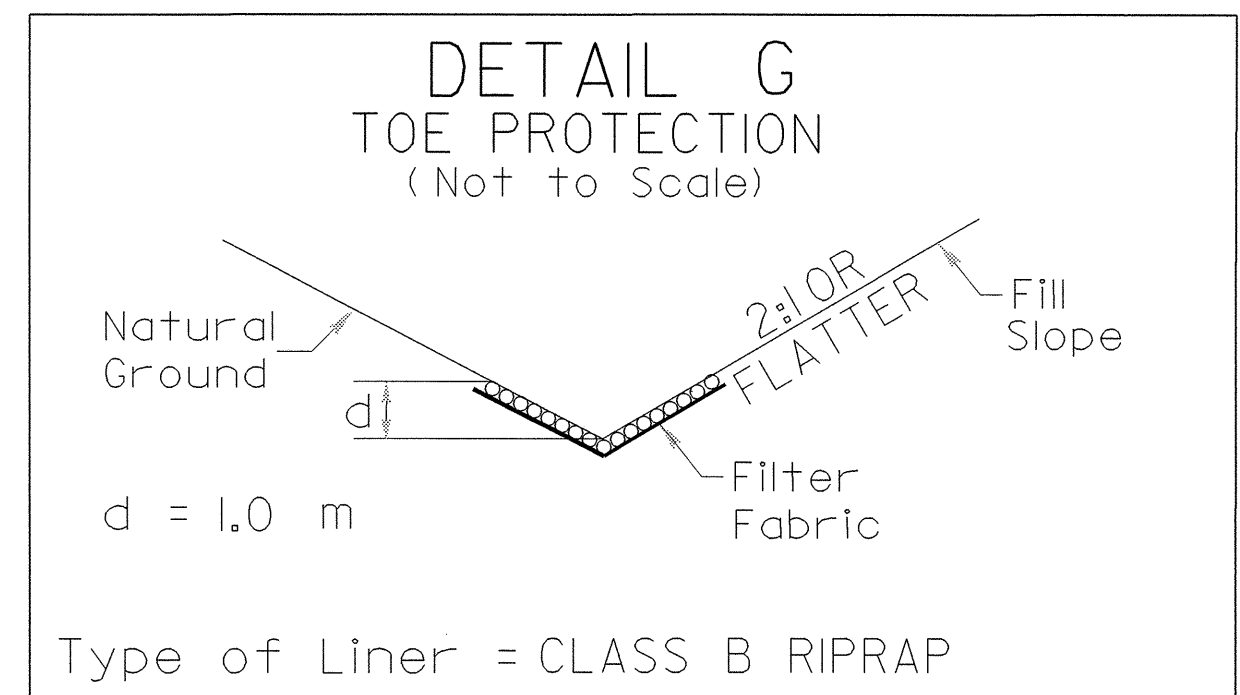

-L- STA. 12+27 - 12+37 RT
-DET- STA. 12+08 - 12+21 RT (TEMP)
-DET- STA. 12+40 - 12+67 RT (TEMP)

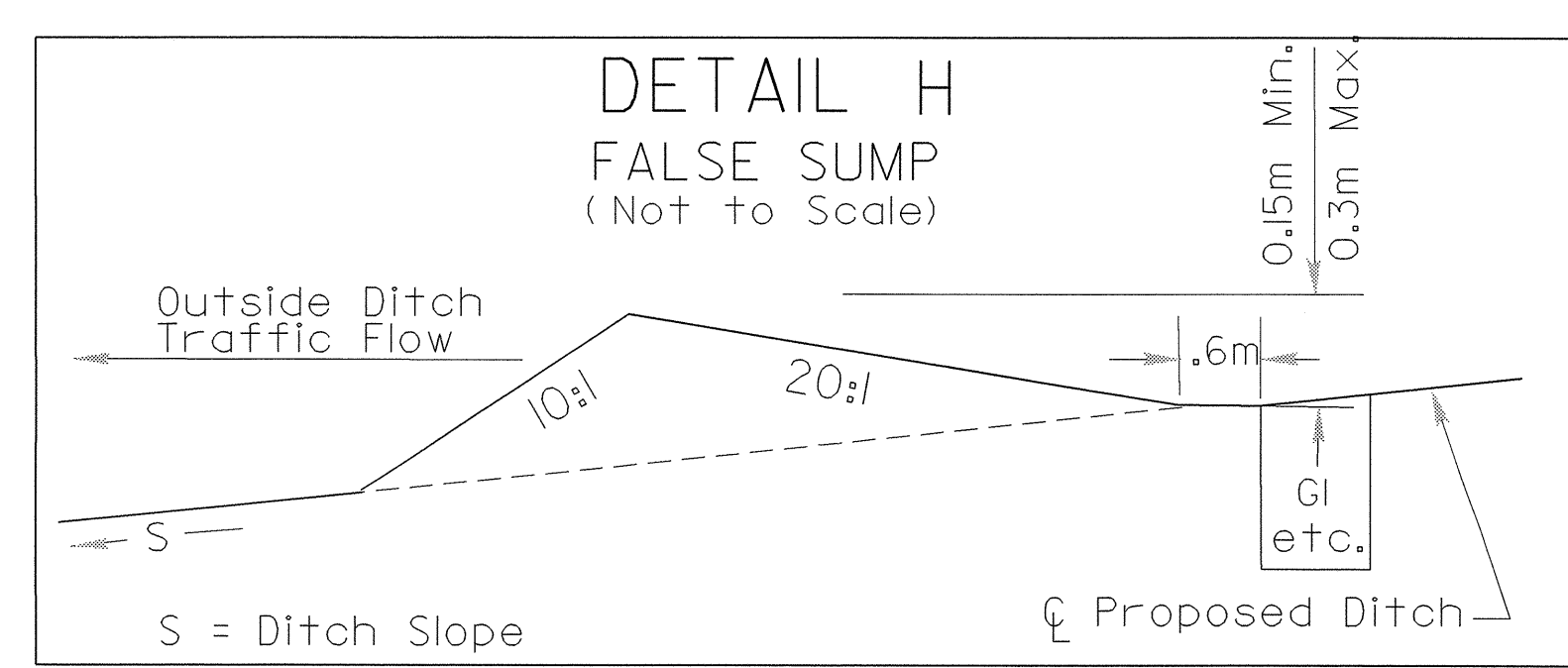

-DRIVE 1- STA. 10+04 RT

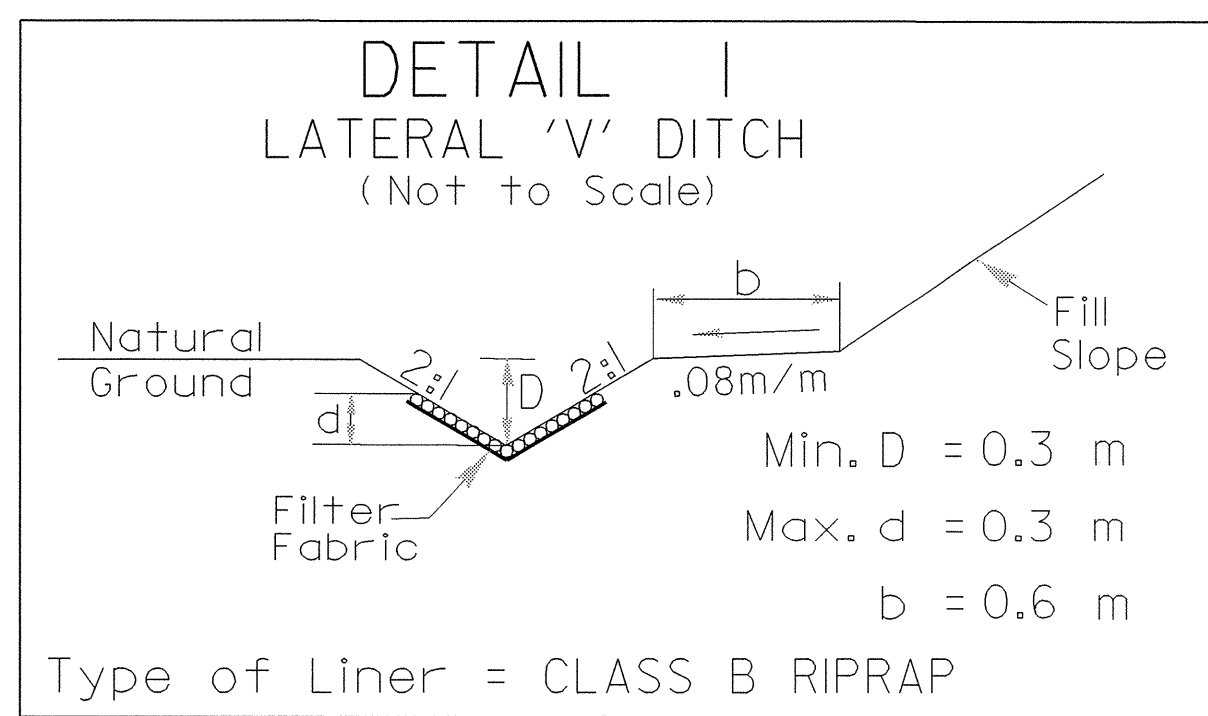

-L- STA. 13+47.473 - 13+60.173 RT
ESTIMATED DDE = 4 CM

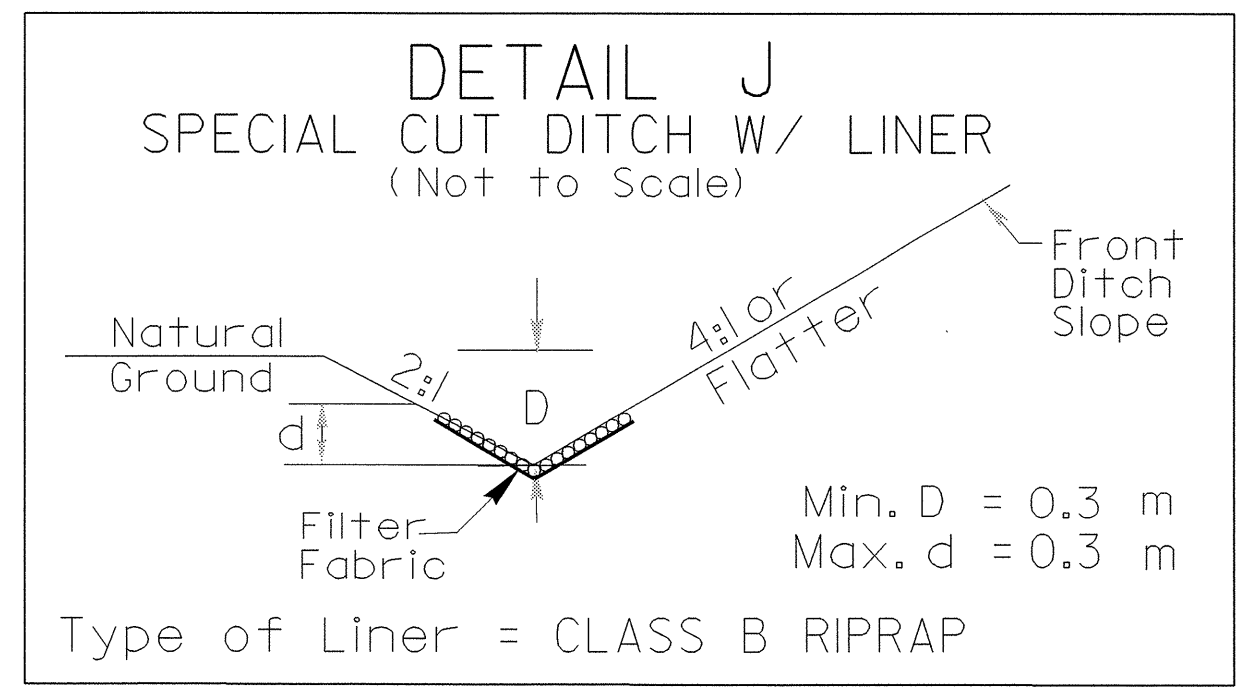

-L- STA. 12+00 - 12+15 RT
-L- STA. 13+27.473 - 13+47.473 LT
-DET- STA. 12+55 - 12+75 LT (TEMP)

PL 95001, 2004 09/07 WAKABIDAVIS, Nov 03 B3376, 4/9