

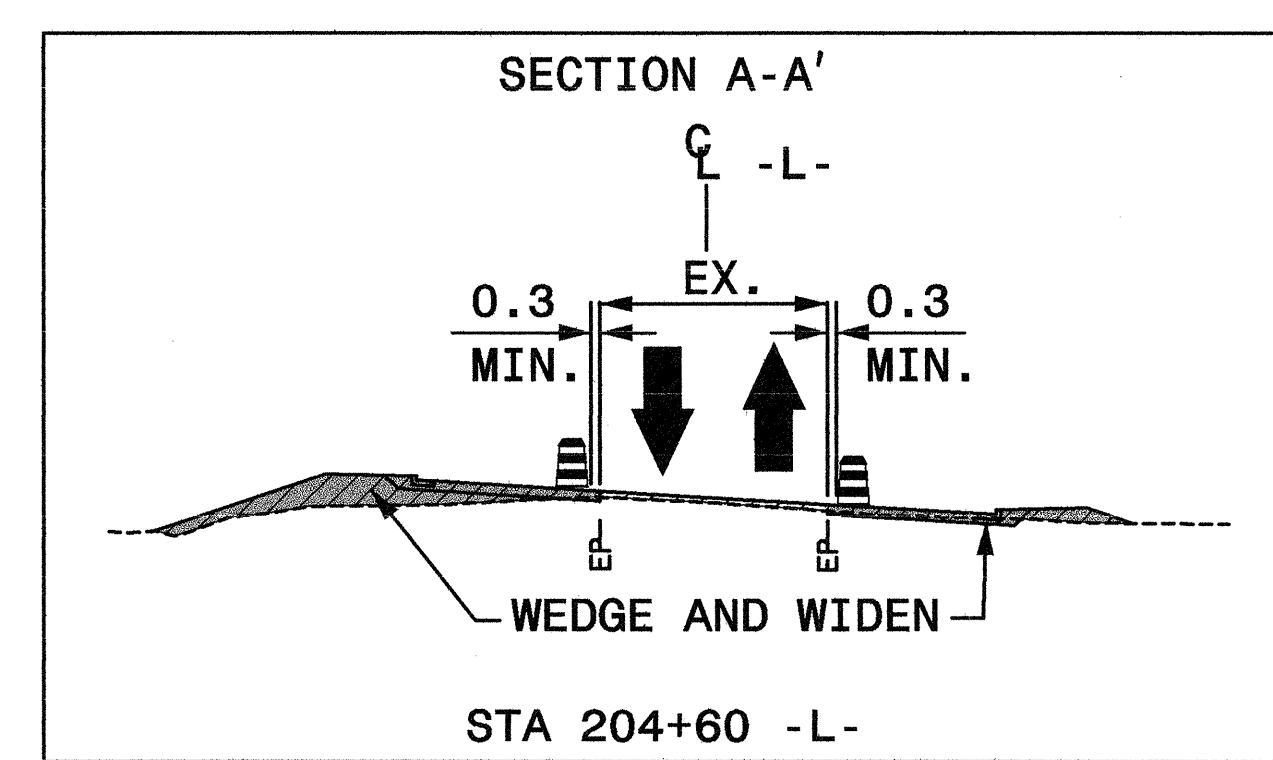

PROJ. REFERENCE NO.	SHEET NO.
R-2539C	TCP-13

**GREENHORNE & O'MARA, INC.**  
 5565 CENTERVIEW DRIVE, SUITE 107  
 RALEIGH, NORTH CAROLINA 27606  
 (919) 851-1919

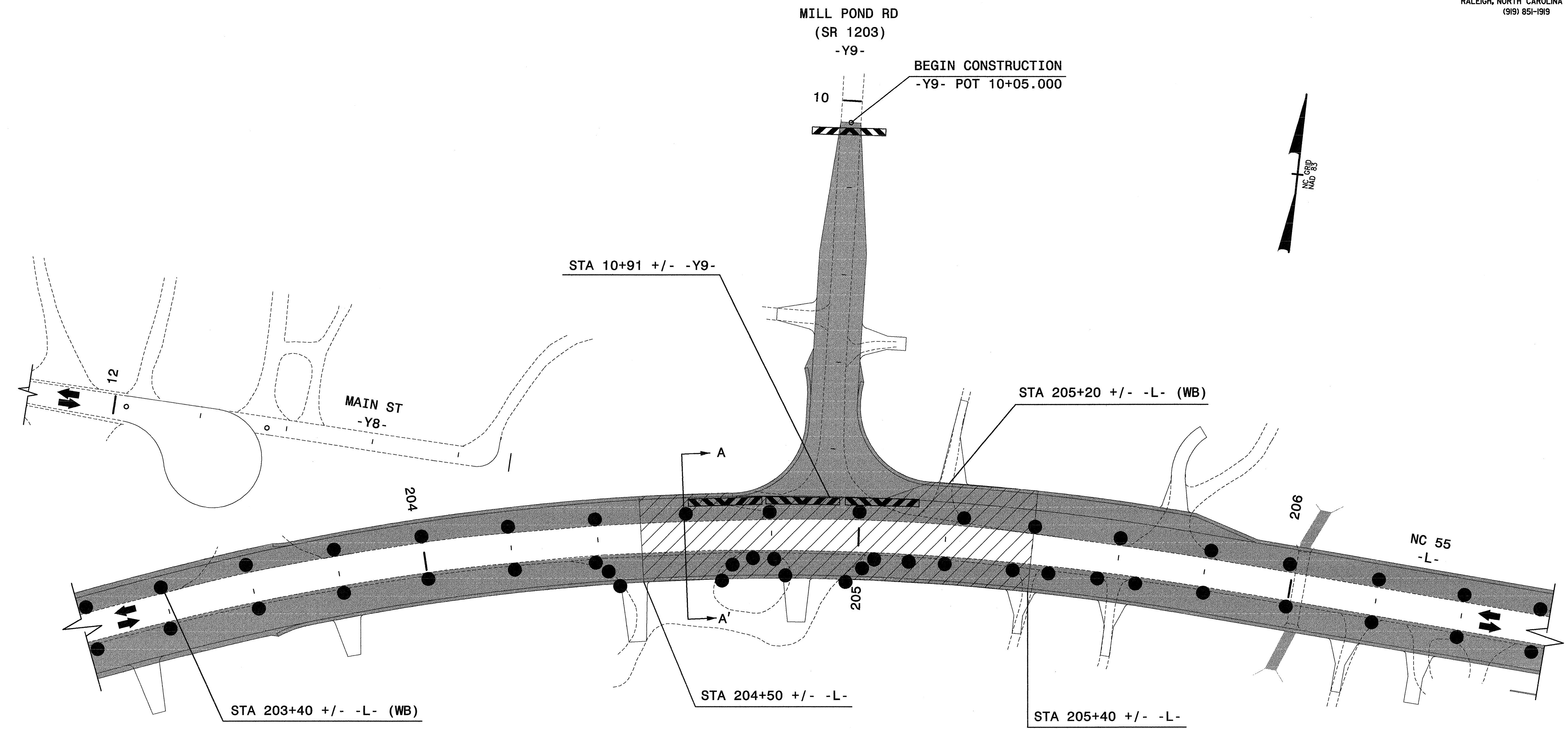

- LEGEND**
- = PROPOSED CONSTRUCTION AND/OR RESURFACING
  - = WEDGING & WIDENING

APPROVED: <i>Dennis Keen</i> DATE: 9-3-04	<b>DETAIL I-E</b> <b>-Y9- CONSTRUCTION</b>							
	SCALE: NONE							
	DATE: 8/2/04							
	DESIGN BY: PMW							
	REVIEWED BY: DCK							
		<table border="1" style="width: 100%;"> <tr> <th colspan="2">REVISIONS</th> </tr> <tr> <td> </td> <td> </td> </tr> <tr> <td> </td> <td> </td> </tr> </table>	REVISIONS					
REVISIONS								
		<small>CADD FILE: Y5CONSTR.DGN</small>						

\$\$\$SYTIME\$\$\$  
 \$\$\$DCN\$\$\$  
 \$\$\$USERNAME\$\$\$