

**NOTES**

STIRRUPS IN CAP MAY BE SHIFTED AS NECESSARY TO CLEAR DOWELS.

PIPE DRAINS MAY BE SHIFTED SLIGHTLY AS NECESSARY TO CLEAR REINFORCING STEEL AND DOWELS.

THE LATERAL GUIDE AT EACH END OF THE CAP IS NOT TO BE POURED UNTIL AFTER THE CORED SLAB UNITS ARE IN PLACE.

THE CONTRACTOR SHALL PROVIDE FOR INSTALLATION OF THE 4" DIAMETER DRAIN PIPE THROUGH THE WING WALL AS REQUIRED FOR REINFORCED BRIDGE APPROACH FILLS, SEE THE ROADWAY PLANS. REINFORCING STEEL IN THE WING WALL MAY BE SHIFTED AS NECESSARY TO CLEAR THE DRAIN PIPE.

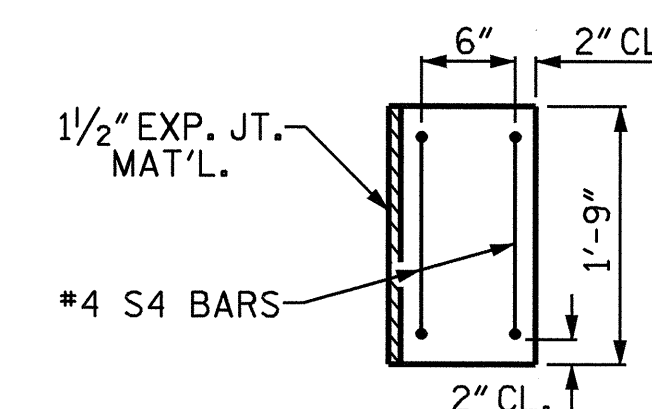

**LATERAL GUIDE**

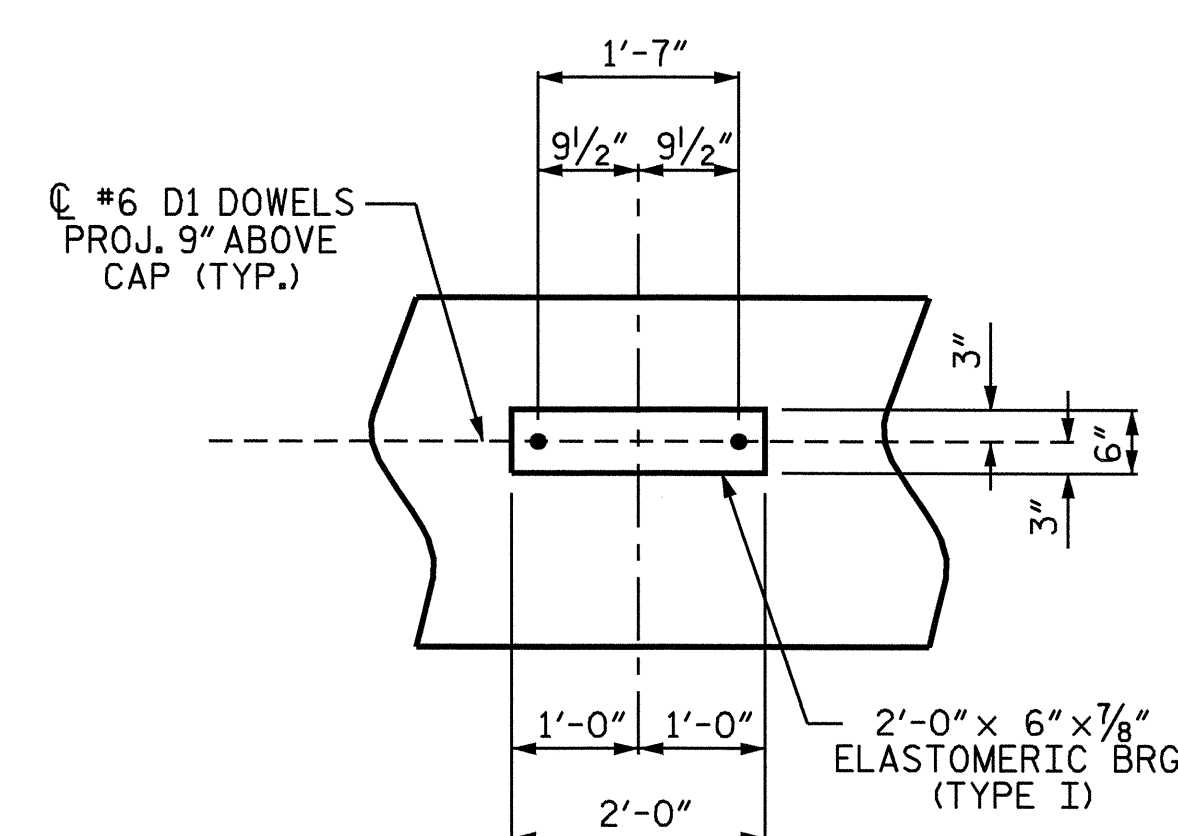

**DETAIL "A"**

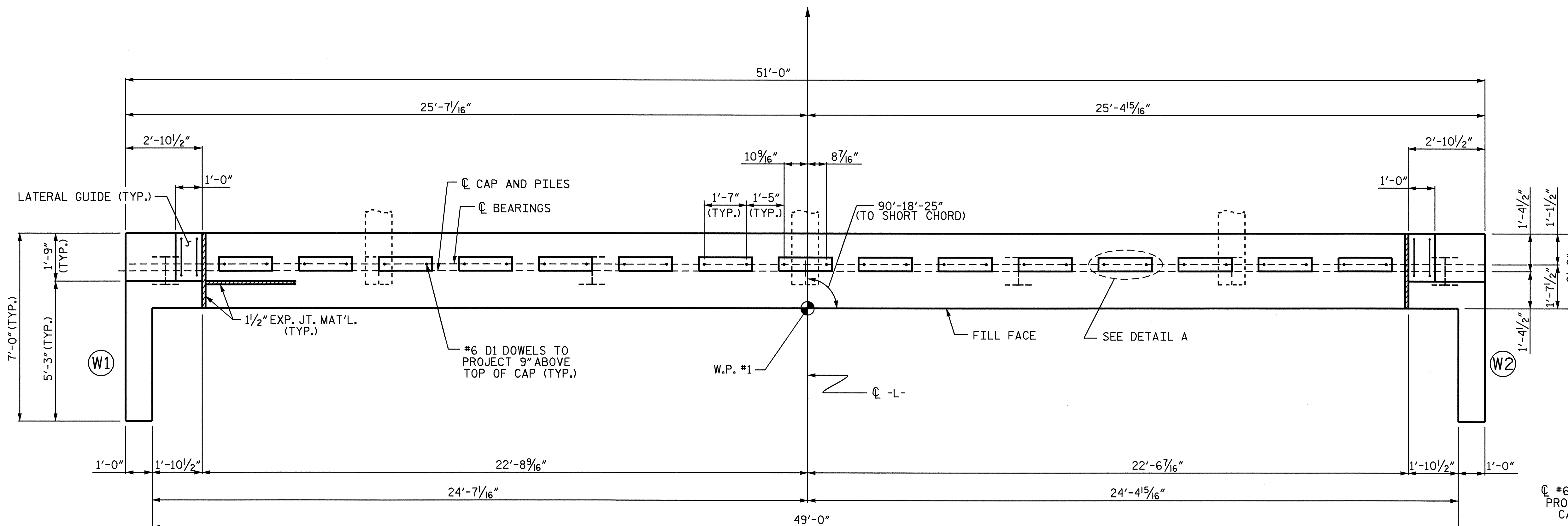

**PLAN**

TOP OF PILE ELEVATIONS	ELEVATION
PILE #1	760.113
PILE #2	759.953
PILE #3	759.793
PILE #4	759.633
PILE #5	759.473
PILE #6	759.313
PILE #7	759.153

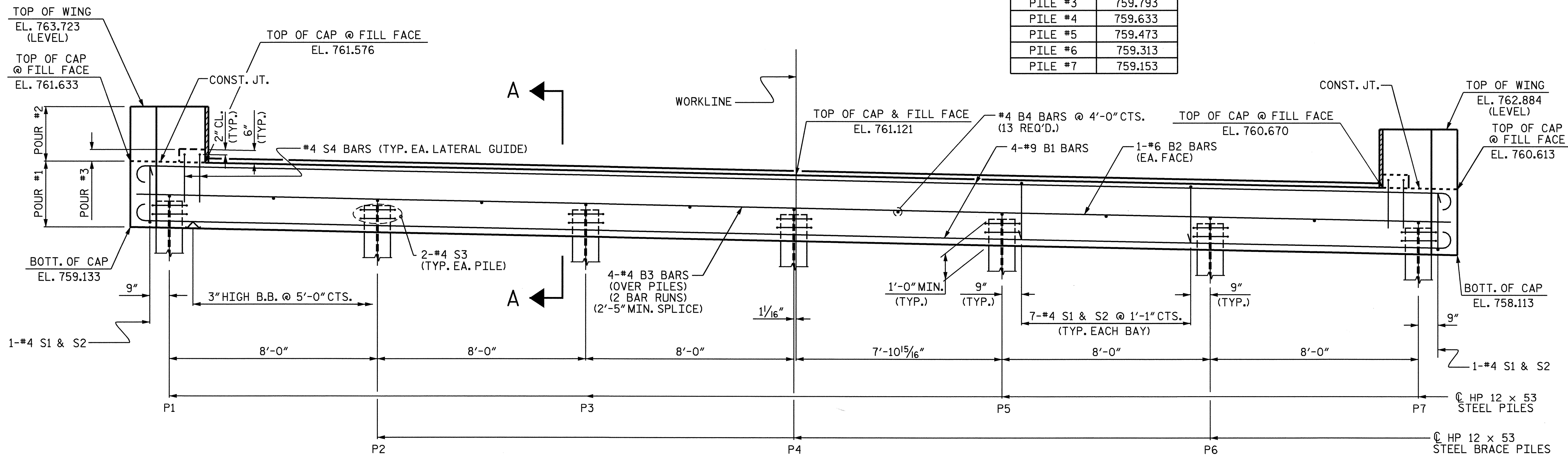

**ELEVATION**

PROJECT NO. B-3454  
FORSYTH COUNTY  
STATION: 20+93.00 -L-

SHEET 1 OF 3

STATE OF NORTH CAROLINA  
DEPARTMENT OF TRANSPORTATION  
RALEIGH

**SUBSTRUCTURE  
END BENT #1**

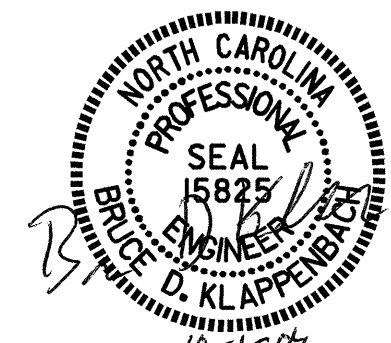

REVISIONS						SHEET NO.
NO.	BY:	DATE:	NO.	BY:	DATE:	TOTAL SHEETS
1			3			5-13
2			4			27

DRAWN BY : J.B. WILSON DATE : 8/04  
CHECKED BY : D.A. GLADDEN DATE : 8/04

29-SEP-2004 14:32  
W:\squad\B3454\jwilson\Microstation\B3454.sd.E1.01.dgn  
mshalkh