

EDI MODEL 2010ECL CONFLICT MONITOR

PROGRAMMING DETAIL

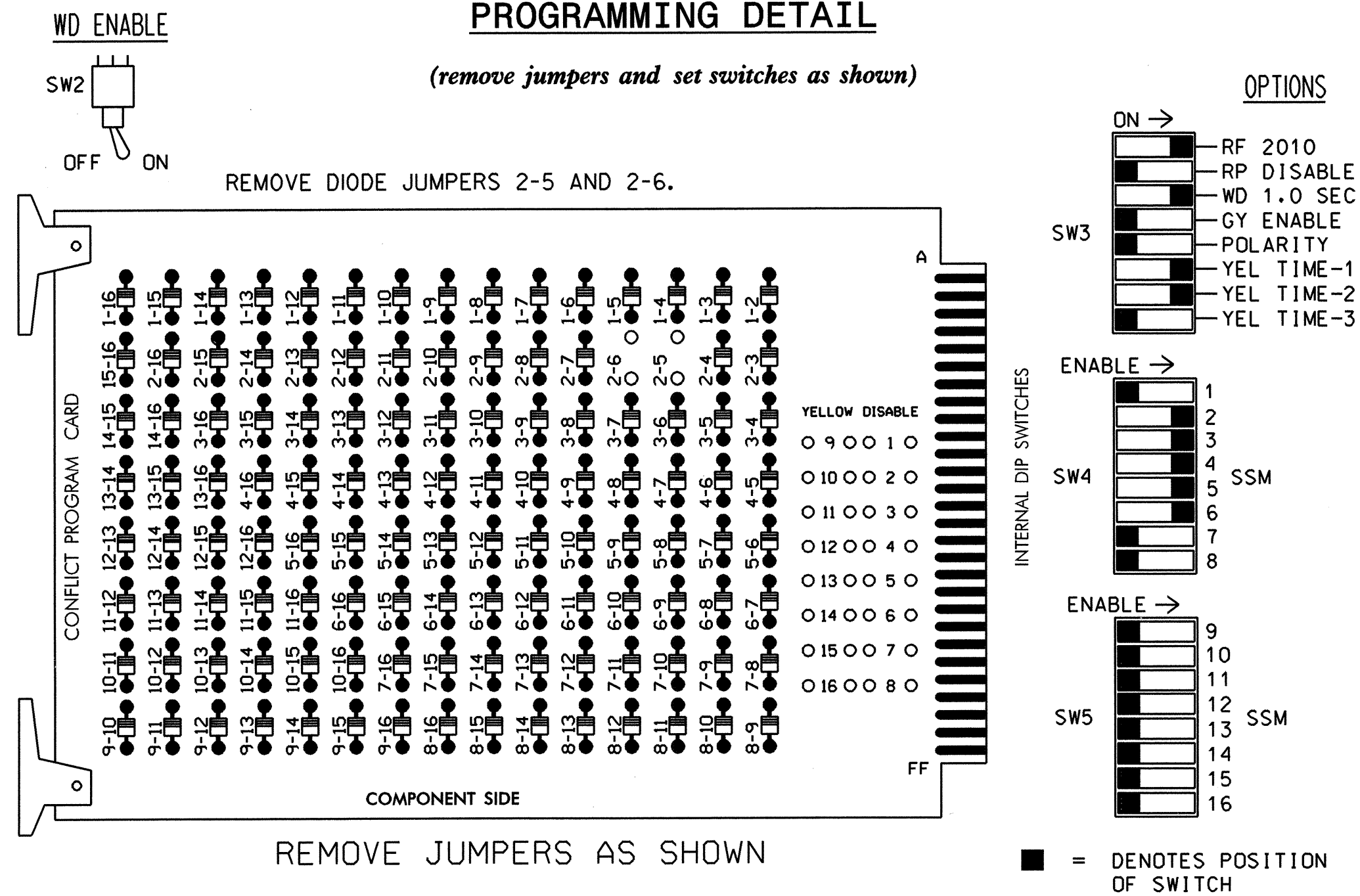

NOTES:

- CARD IS PROVIDED WITH ALL DIODE JUMPERS IN PLACE. REMOVAL OF ANY JUMPER ALLOWS ITS CHANNELS TO RUN CONCURRENTLY.
- MAKE SURE JUMPERS SEL1-SEL5 ARE PRESENT ON THE MONITOR BOARD.

INPUT FILE POSITION LAYOUT

(front view)

	1	2	3	4	5	6	7	8	9	10	11	12	13	14
FILE "I" U	∅ 2 2A	∅ 3 3A	∅ 3 3B	∅ 4 4A	∅ 4 4A	∅ 4 4A	∅ 4 4A	∅ 4 4A	∅ 4 4A	∅ 4 4A	∅ 4 4A	∅ 4 4A	∅ 4 4A	∅ 4 4A
FILE "J" U	∅ 5 5A	∅ 5 5B	∅ 5 5C	∅ 6 6A	∅ 6 6B	∅ 6 6C	∅ 6 6C	∅ 6 6C	∅ 6 6C	∅ 6 6C	∅ 6 6C	∅ 6 6C	∅ 6 6C	∅ 6 6C

EX.: 1A, 2A, ETC. = LOOP NO.'S

FS = FLASH SENSE
ST = STOP TIME
PRE2 = EMERG. VEH. PREEMPT

INPUT FILE CONNECTION & PROGRAMMING CHART

LOOP NO.	LOOP TERMINAL	INPUT FILE POS.	PIN NO.	INPUT ASSIGNMENT NO.	DETECTOR NO.	NEMA PHASE	CALL	EXTEND	FULL TIME DELAY	STRETCH TIME	DELAY TIME
2A	TB2-5,6	I2U	39	1	2	2	Y	Y	-	---	---
2B	TB2-7,8	I2L	43	5	12	2	Y	Y	-	---	---
3A	TB2-9,10	I3U	63	25	32	3	Y	Y	-	---	3
3B	TB2-11,12	I3L	76	38	42	3	Y	Y	-	---	---
4A	TB4-9,10	I6U	41	3	4	4	Y	Y	-	---	3
5A ¹	TB3-5,6	J2U	40	2	6	2	Y	Y	Y	---	3
	TB3-7,8	J2L	44	6	18	5	Y	Y	-	---	15
5B	TB3-9,10	J3U	64	26	36	5	Y	Y	-	---	10
5C	TB3-11,12	J3L	77	39	46	5	Y	Y	-	---	10
6A	TB5-9,10	J6U	42	4	8	6	Y	Y	-	---	---
6B	TB5-11,12	J6L	46	8	18	6	Y	Y	-	---	---
6C	TB7-1,2	J7U	66	28	38	6	Y	Y	Y	---	3

¹ DENOTES ADD JUMPERS FOR LOOP 5A FROM TB3-5 TO TB3-7, AND FROM TB3-6 TO TB3-8.

INPUT FILE POSITION LEGEND: J2L
FILE J
SLOT 2
LOWER

NOTES

- TO PREVENT "FLASH-CONFLICT" PROBLEMS, INSERT RED FLASH PROGRAM BLOCKS FOR ALL UNUSED VEHICLE LOAD SWITCHES IN THE OUTPUT FILE. THE INSTALLER SHALL VERIFY THAT SIGNAL HEADS FLASH IN ACCORDANCE WITH THE SIGNAL PLANS.
- ENSURE THAT RED ENABLE IS ACTIVE AT ALL TIMES DURING NORMAL OPERATION. TO PREVENT RED FAILURES ON UNUSED MONITOR CHANNELS, TIE UNUSED RED MONITOR INPUTS 1,7,8,9,10,11,12,13,14,15 & 16 TO LOAD SWITCH AC+ PER CABINET MANUFACTURER'S INSTRUCTIONS.
- PROGRAM CONTROLLER TO START UP IN PHASES 2 AND 6 GREEN.
- ENABLE SIMULTANEOUS GAP-OUT FEATURE, ON CONTROLLER UNIT, FOR ALL PHASES.
- PROGRAM PHASES 2 AND 6, ON CONTROLLER UNIT, FOR VARIABLE INITIAL AND GAP REDUCTION.

FIELD CONNECTION HOOK-UP CHART

LOAD SWITCH NO.	S1	S2	S2P	S3	S4	S4P	S5	S6	S6P	S7	S8	S8P
PHASE	1	2	2 PED	3	4	4 PED	5	6	6 PED	7	8	8 PED
SIGNAL HEAD NO.	NU	21,22	NU	31 32	41 42	NU	21,32	61,62	NU	NU	NU	NU
GREEN		130		118 118	103 103			136				
YELLOW		129		117 117	102 102			135				
RED		128		116 116	101 101		*	134				
RED ARROW												
YELLOW ARROW								132				
GREEN ARROW				118	103			133				
⚠												
👤												

NU = NOT USED

* DENOTES INSTALL LOAD RESISTOR. SEE LOAD RESISTOR INSTALLATION DETAIL THIS PAGE.

EQUIPMENT INFORMATION

CONTROLLER.....CONTRACTOR SUPPLIED 2070L
CABINETCONTRACTOR SUPPLIED 332
SOFTWAREECONOLITE OASIS
CABINET MOUNT.....BASE
OUTPUT FILE POSITIONS...12
LOAD SWITCHES USED.....S2,S3,S4,S5,S6
PHASES USED.....2,3,4,5,6
OVERLAPS.....NONE

BACK-UP PROTECTION PROGRAMMING DETAIL

(program controller as shown below)

- FROM MAIN MENU PRESS '2' (PHASE CONTROL), THEN '1' (PHASE CONTROL FUNCTIONS). SCROLL TO THE BOTTOM OF THE MENU AND ENABLE DYNAMIC/BACKUP CONTROL FUNCTION 1.
- FROM PHASE CONTROL FUNCTIONS MENU PRESS '2' (DYNAMIC/BACKUP CONTROL FUNCTIONS).

DYNAMIC/BACKUP CONTROL FUNCTION #01
OVERLAPS: ABCDEFGHIJKLMNOP
IF OVERLAPS ARE ACTIVE :
OR PHASES: 12345678910111213141516
IF PHASES ARE ON : X
OMIT PHASES : X
CALL PHASES : X

BACKUP PROTECTION PROGRAMMING COMPLETE

LOAD RESISTOR INSTALLATION DETAIL

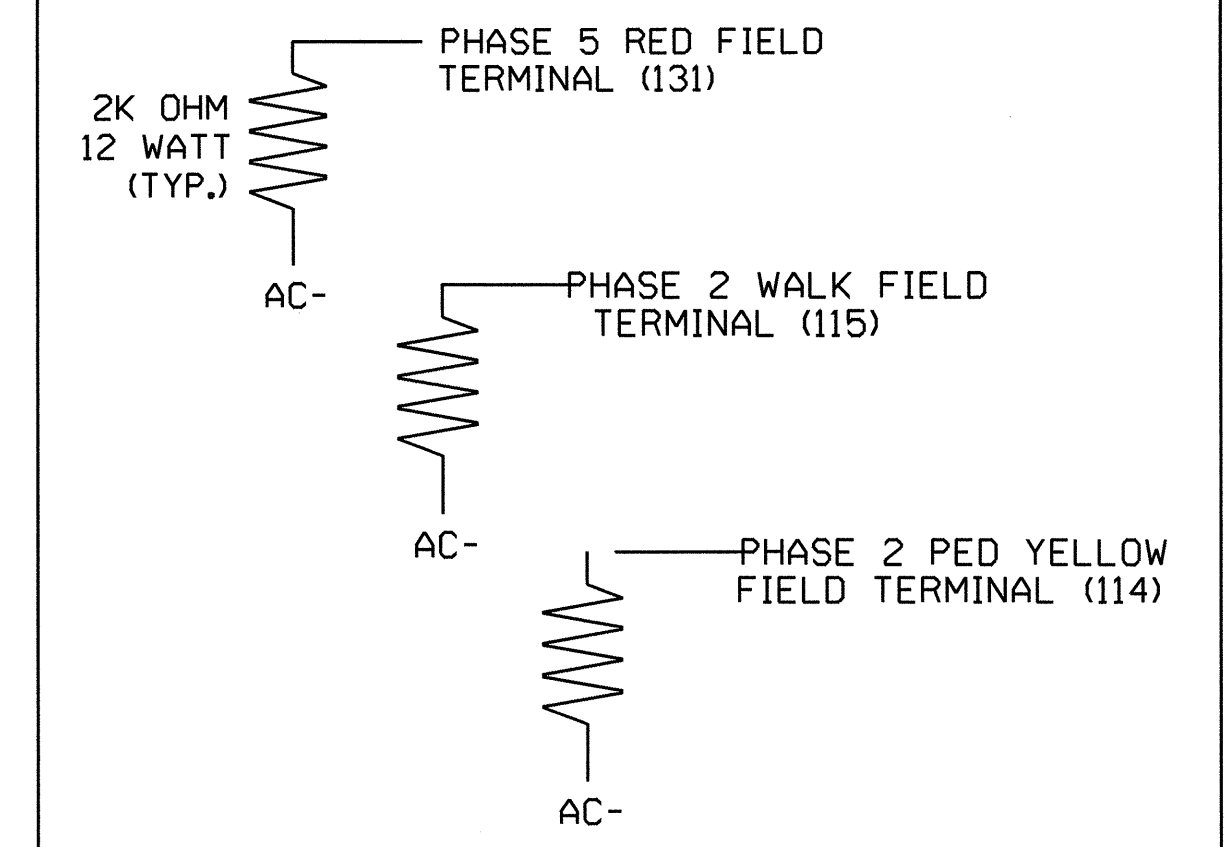

THIS ELECTRICAL DETAIL IS FOR THE SIGNAL DESIGN: 13-0284T2
DESIGNED: 04/14/2003
SEALED: 02/26/2004
REVISED: TBD

TEMPORARY SIGNAL 2 - PHASE II - TCP 29
PAGE 1 OF 2



PLANS PREPARED BY :
RUMMEL KLEPPER & KAHL, LLP
consulting engineers
5800 FARINGDON PLACE SUITE 105
RALEIGH, NORTH CAROLINA 27609-3960
FOR
DIVISION OF HIGHWAYS

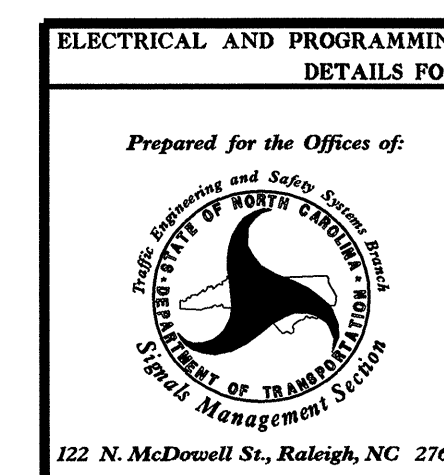

US 25 (HENDERSONVILLE ROAD)
AT
NC 146 (LONG SHOALS ROAD)

DIVISION 13 BUNCOMBE COUNTY ASHEVILLE
PLAN DATE: JULY 2003 REVIEWED BY: J O DEATON
PREPARED BY: M W YALCH REVIEWED BY:

REVISIONS	INIT.	DATE

SEAL
NORTH CAROLINA PROFESSIONAL ENGINEER
JAMES O. DEATON
07438
DATE: 2/26/04