

AT DAM IN OPEN JOINT
(THIS IS TO BE USED ONLY
WHEN SLIP FORM IS USED)

1/2" EXP. JT. MAT'L HELD IN PLACE WITH GALVANIZED NAILS.
(NOTE: OMIT EXP. JT. MAT'L WHEN SLIP FORM IS USED.)

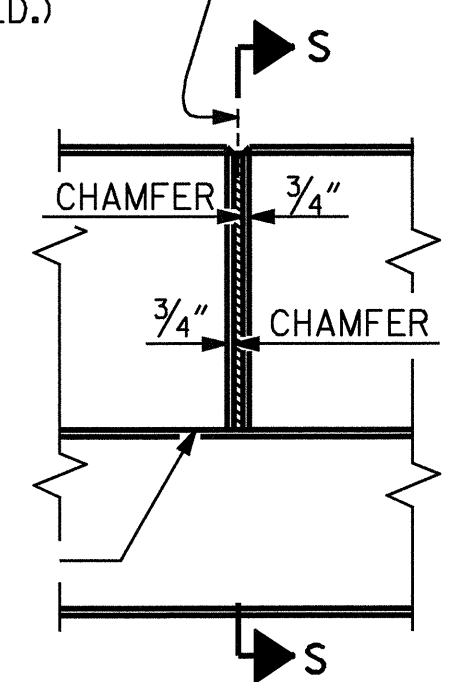

ELEVATION AT EXPANSION JOINTS
BARRIER RAIL DETAILS

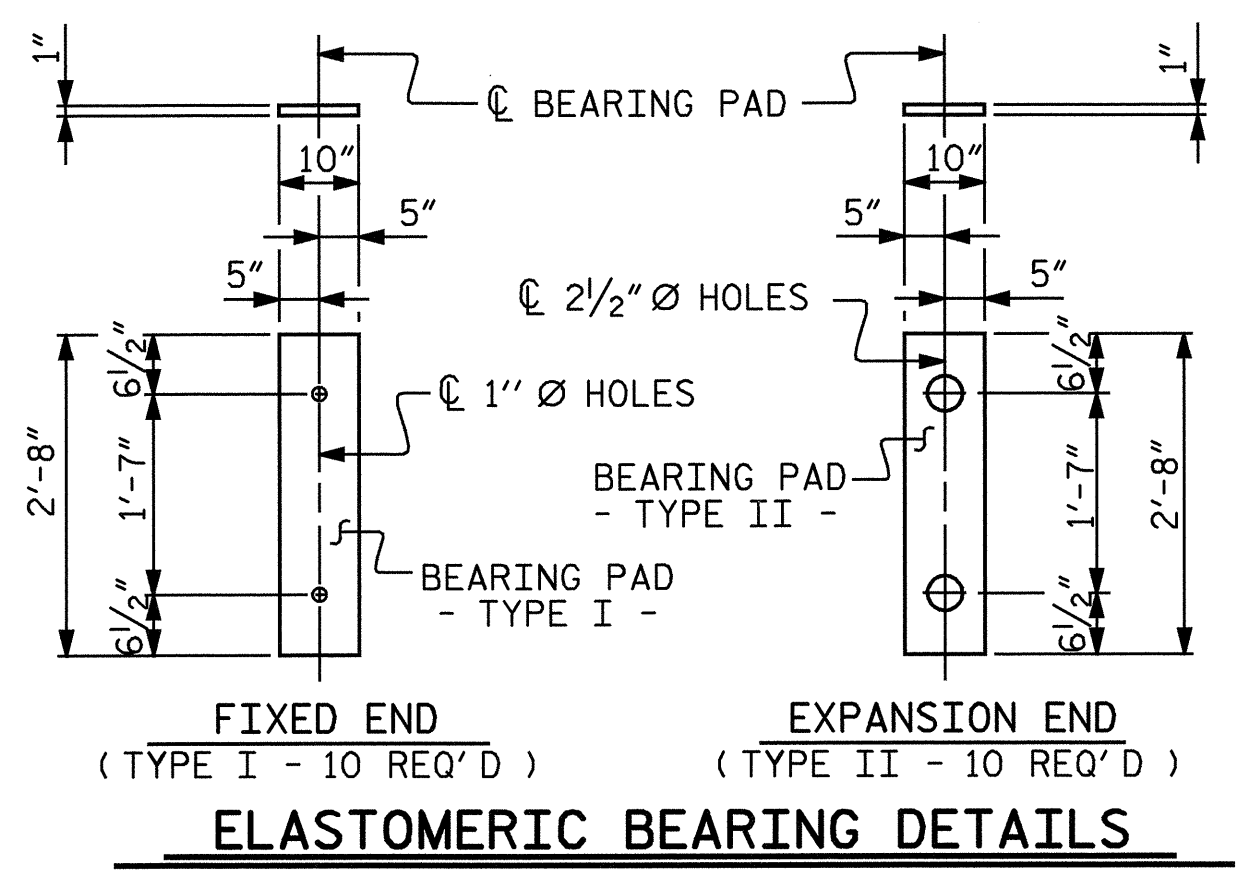

FIXED END (TYPE I - 10 REQ'D) EXPANSION END (TYPE II - 10 REQ'D)
ELASTOMERIC BEARING DETAILS

BAR TYPES

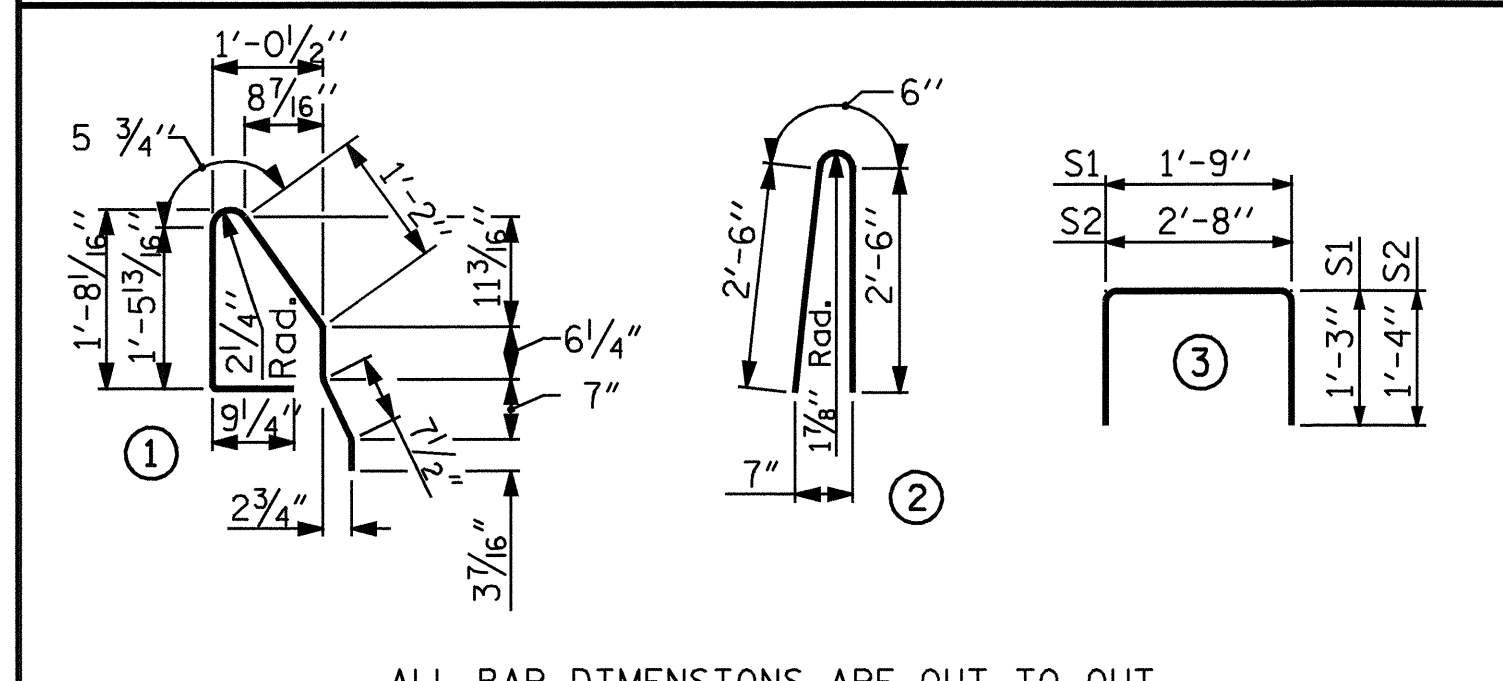

ALL BAR DIMENSIONS ARE OUT TO OUT

BILL OF MATERIAL FOR ONE CORED SLAB SECTION

BAR	NUMBER	SIZE	TYPE	EXTERIOR UNIT		INTERIOR UNIT	
				LENGTH	WEIGHT	LENGTH	WEIGHT
B1	4	#4	STR	25'-9"	69	25'-9"	69
S1	8	#4	3	4'-3"	23	4'-3"	23
S2	98	#4	3	5'-4"	349	5'-4"	349
*S3	51	#5	1	5'-4"	284		
REINFORCING STEEL				LBS.	441		441
*EPOXY COATED REINFORCING STEEL				LBS.	284		
5,000 P.S.I. CONCRETE				CU. YDS.	7.0		7.0
1/2" Ø L.R. STRANDS				No.	19		19

BILL OF MATERIAL FOR CONCRETE BARRIER RAIL

SPAN A					
BAR	NO.	SIZE	TYPE	LENGTH	WEIGHT
*B2	14	#5	STR	25'-0"	365
*B3	14	#5	STR	24'-0"	350
*S4	102	#5	2	5'-6"	585
*EPOXY COATED REINFORCING STEEL				LBS.	1300
CLASS AA CONCRETE				CU. YDS.	11.1
TOTAL LENGTH OF CONCRETE BARRIER RAIL				LIN. FT.	99.5

DEAD LOAD DEFLECTION AND CAMBER

	INTERIOR UNIT	EXTERIOR UNIT
	3'-0" x 1'-9"	3'-0" x 1'-9"
	1/2" Ø L.R. STRAND	1/2" Ø L.R. STRAND
CAMBER (SLAB ALONE IN PLACE)	↑ 1 5/16"	↑ 1 5/16"
DEFLECTION DUE TO SUPERIMPOSED DEAD LOAD**	↓ 1/4"	↓ 1/4"
FINAL CAMBER	↑ 1 5/16"	↑ 1 5/16"

** INCLUDES FUTURE WEARING SURFACE

GRADE 270 STRANDS

AREA (SQUARE INCHES)	0.153
ULTIMATE STRENGTH (LBS. PER STRAND)	41,300
APPLIED PRESTRESS (LBS. PER STRAND)	30,980

CORED SLABS REQUIRED

SPAN A			
	NUMBER	LENGTH	TOTAL LENGTH
INTERIOR C.S.	8	49'-9"	398'-0"
EXTERIOR C.S.	2	49'-9"	99'-6"
TOTAL	10	49'-9"	497'-6"

NOTES

ALL PRESTRESSING STRANDS SHALL BE 7-WIRE LOW RELAXATION GRADE 270 STRANDS AND SHALL CONFORM TO AASHTO M203 EXCEPT FOR SAMPLING REQUIREMENTS WHICH SHALL BE IN ACCORDANCE WITH THE STANDARD SPECIFICATIONS.

ALL REINFORCING STEEL CAST WITH THE CORED SLAB SECTIONS SHALL BE GRADE 60 AND SHALL BE INCLUDED IN THE UNIT PRICE BID FOR PRESTRESSED CONCRETE CORED SLABS.

RECESSES FOR TRANSVERSE STRANDS SHALL BE GROUTED AFTER THE TENSIONING OF THE STRANDS.

THE 2 1/2" Ø DOWEL HOLES AT FIXED ENDS OF SLAB SECTIONS SHALL BE FILLED WITH GROUT. THE 2 1/2" Ø DOWEL HOLES AT EXPANSION ENDS OF SLAB SECTIONS SHALL BE FILLED WITH JOINT SEALER MATERIAL TO 1/2" ABOVE THE TOP OF DOWELS AND THEN FILLED WITH GROUT.

THE JOINT SEALER MATERIAL SHALL CONFORM TO THE REQUIREMENTS OF TYPE B LOW MODULUS SILICONE SEALANT. THE 2" Ø BACKER ROD SHALL CONFORM TO THE REQUIREMENTS OF TYPE M BOND BREAKER. SEE SECTION 1028 OF THE STANDARD SPECIFICATIONS.

WHEN CORED SLABS ARE CAST, A POSITIVE HOLD-DOWN SYSTEM SHALL BE EMPLOYED TO PREVENT VOIDS FROM RISING OR MOVING SIDWAYS. THIS SYSTEM SHALL BE DESIGNED TO BE LEFT IN PLACE UNTIL THE CONCRETE HAS REACHED RELEASE STRENGTH. AT LEAST THREE WEEKS PRIOR TO CASTING CORED SLABS, THE CONTRACTOR SHALL SUBMIT TO THE ENGINEER FOR REVIEW AND COMMENT, DETAILED DRAWINGS OF THE PROPOSED HOLD-DOWN SYSTEM. IN ADDITION TO STRUCTURAL DETAILS, LOCATION AND SPACING OF THE HOLD-DOWNS SHALL BE INDICATED.

THE TRANSFER OF LOAD FROM THE ANCHORAGES TO THE CORED SLAB UNIT SHALL BE DONE WHEN THE CONCRETE HAS REACHED A COMPRESSIVE STRENGTH OF NOT LESS THAN 4000 PSI.

ALL REINFORCING STEEL IN BARRIER RAILS SHALL BE EPOXY COATED.

PRESTRESSING STRANDS SHALL BE CUT FLUSH WITH THE CORED SLAB UNIT ENDS.

APPLY EPOXY PROTECTIVE COATING TO CORED SLAB UNIT ENDS. FOR EPOXY PROTECTIVE COATING, SEE SPECIAL PROVISIONS.

VERTICAL GROOVED CONTRACTION JOINTS, 1/2" IN DEPTH, SHALL BE TOOLED IN ALL EXPOSED FACES OF THE BARRIER RAIL AND IN ACCORDANCE WITH ARTICLE 825-10(B) OF THE STANDARD SPECIFICATIONS. A VERTICAL CONTRACTION JOINT SHALL BE LOCATED AT EACH THIRD POINT BETWEEN BARRIER RAIL EXPANSION JOINTS. ONLY ONE CONTRACTION JOINT IS REQUIRED AT MIDPOINT OF BARRIER RAIL SEGMENTS LESS THAN 20 FEET IN LENGTH AND NO CONTRACTION JOINTS ARE REQUIRED FOR THOSE SEGMENTS LESS THAN 10 FEET IN LENGTH.

FOR ELASTOMERIC BEARINGS, SEE SPECIAL PROVISIONS.

FOR PRESTRESSED CONCRETE MEMBERS, SEE SPECIAL PROVISIONS.

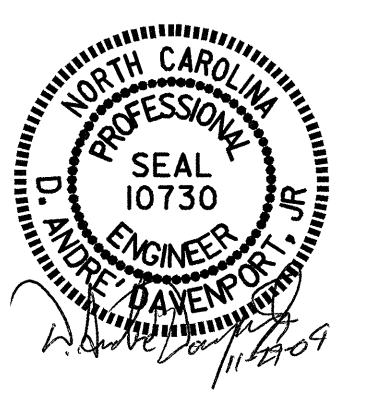

PROJECT NO. B-3670
JOHNSTON COUNTY
STATION: 15+41.00-L-

SHEET 4 OF 4

STATE OF NORTH CAROLINA
DEPARTMENT OF TRANSPORTATION
RALEIGH

3'-0" X 1'-9"
PRESTRESSED
CONCRETE CORED
SLAB UNIT

REVISIONS						SHEET NO.
NO.	BY:	DATE:	NO.	BY:	DATE:	S-7
1			3			TOTAL SHEETS
2			4			17

ASSEMBLED BY : D. G. ELY/DAD	DATE : 4-04
CHECKED BY : H. T. BARBOUR	DATE : 6-03
DRAWN BY : WJH 4/89	REV. 8/16/99 RWW/LES
CHECKED BY : FCJ 5/89	REV. 10/17/00 RWW/LES
	REV. 7/10/01R RWW/LES