

040397

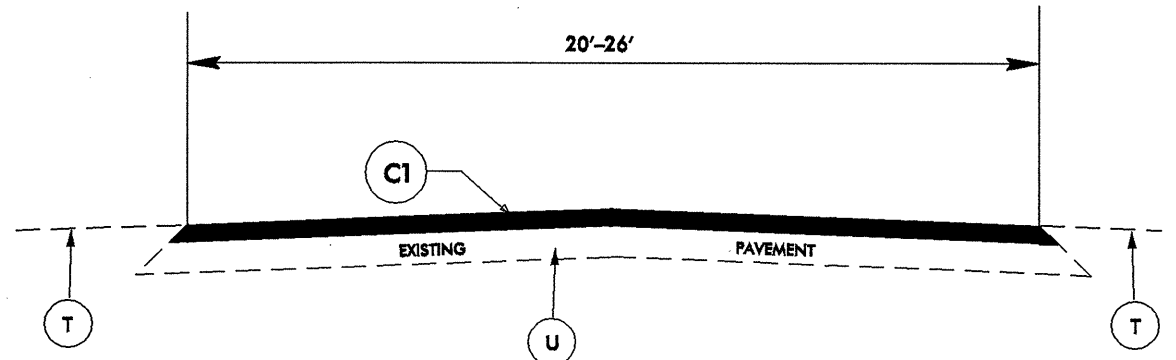

TYPICAL SECTION NO.1

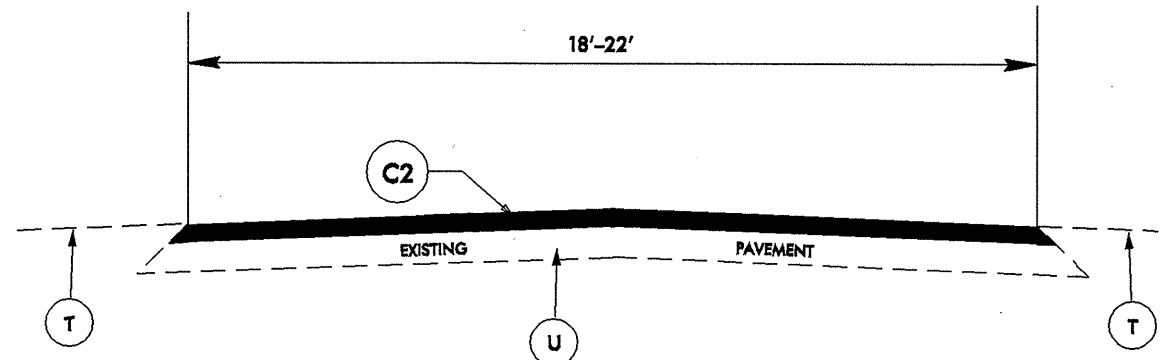

TYPICAL SECTION NO.2

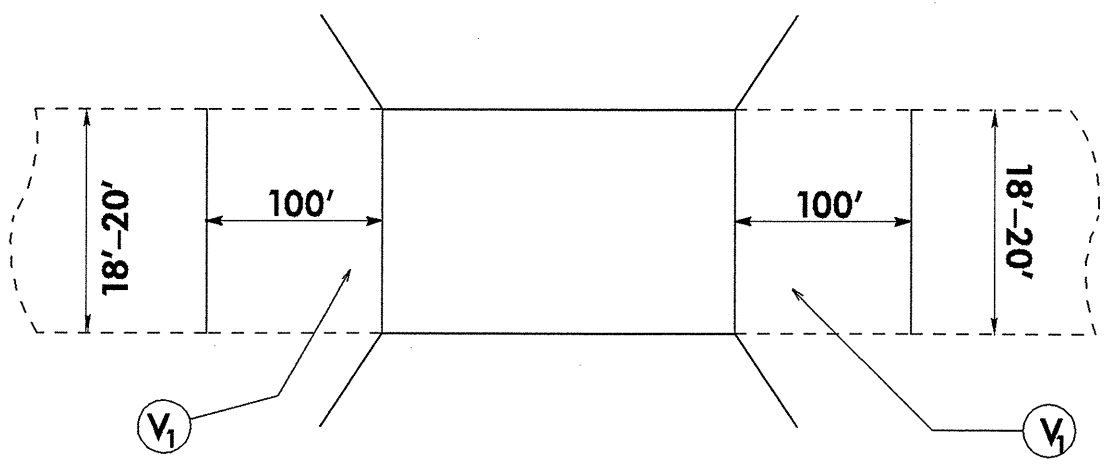

TYPICAL SECTION NO.3

PAVEMENT SCHEDULE	
C1	PROP. APPROX. 1.5" ASPHALT CONC. SURFACE COURSE, TYPE S9.5C, AT AN AVERAGE RATE OF 168 LBS. PER SQ. YD.
C2	PROP. APPROX. 1.5" ASPHALT CONC. SURFACE COURSE, TYPE S9.5B, AT AN AVERAGE RATE OF 168 LBS. PER SQ. YD.
T	EARTH MATERIAL
U	EXISTING PAVEMENT
V1	MILLING ASPHALT PAVEMENT AT BRIDGE TO AN ELEV. 1.5" BELOW CONCRETE BRIDGEDECK, TAPERING IN 100' TO PAVEMENT SURFACE

02-DEC-2004 15:33
 c:\p1\10191\3\chethem.typ-rev.dgn
 15213566