

NOTE : REINFORCING STEEL SHOULD BE FIELD CUT TO MAINTAIN A 2 INCH MINIMUM CLEARANCE TO THE DROP INLET. SEE ROADWAY PLANS.

AT END BENT #1

PLAN

AT END BENT #2

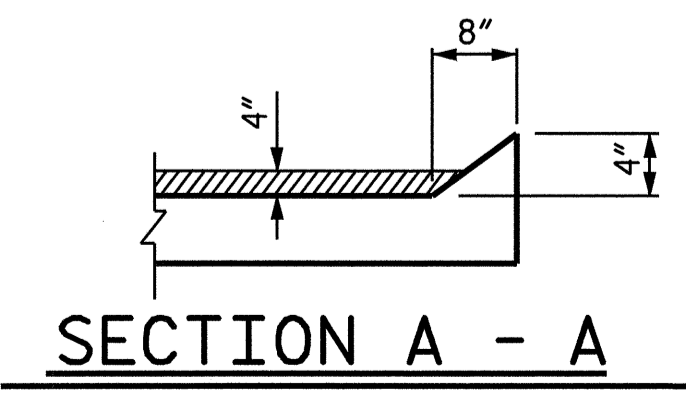

SECTION A - A

DRAWN BY : J.B. WILSON DATE : 5/04
 CHECKED BY : M.G. SHAIKH DATE : 6/04

24-JUN-2004 14:10
 W:\squad\B3504\jwilson\microstation\B-3504.sd.AS.01.dgn
 jwilson

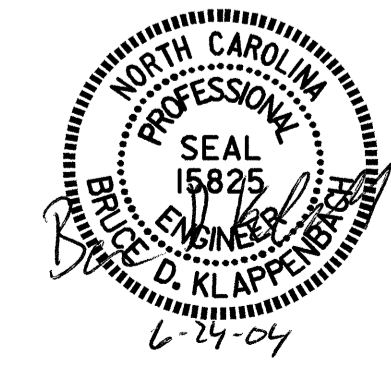

PROJECT NO. B-3504
 RANDOLPH COUNTY
 STATION: 18+70.50 -L-

SHEET 2 OF 5

STATE OF NORTH CAROLINA DEPARTMENT OF TRANSPORTATION RALEIGH					
BRIDGE APPROACH SLAB FOR PRESTRESSED CONCRETE CORED SLAB WITH BARRIER RAIL					
REVISIONS					
NO.	BY:	DATE:	NO.	BY:	DATE:
1			3		
2			4		
SHEET NO.					S-27
TOTAL SHEETS					27

STR. #1