

SECTION THRU RAIL

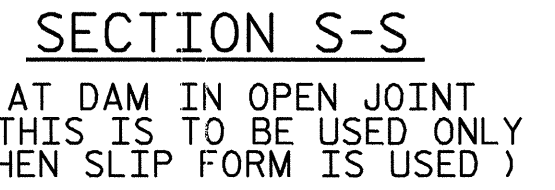

SECTION S-S
AT DAM IN OPEN JOINT
(THIS IS TO BE USED ONLY
WHEN SLIP FORM IS USED)

① 1/2" EXP. JT. MAT'L. HELD IN PLACE WITH GALVANIZED NAILS. (NOTE: OMIT EXP. JT. MAT'L. WHEN SLIP FORM IS USED.)

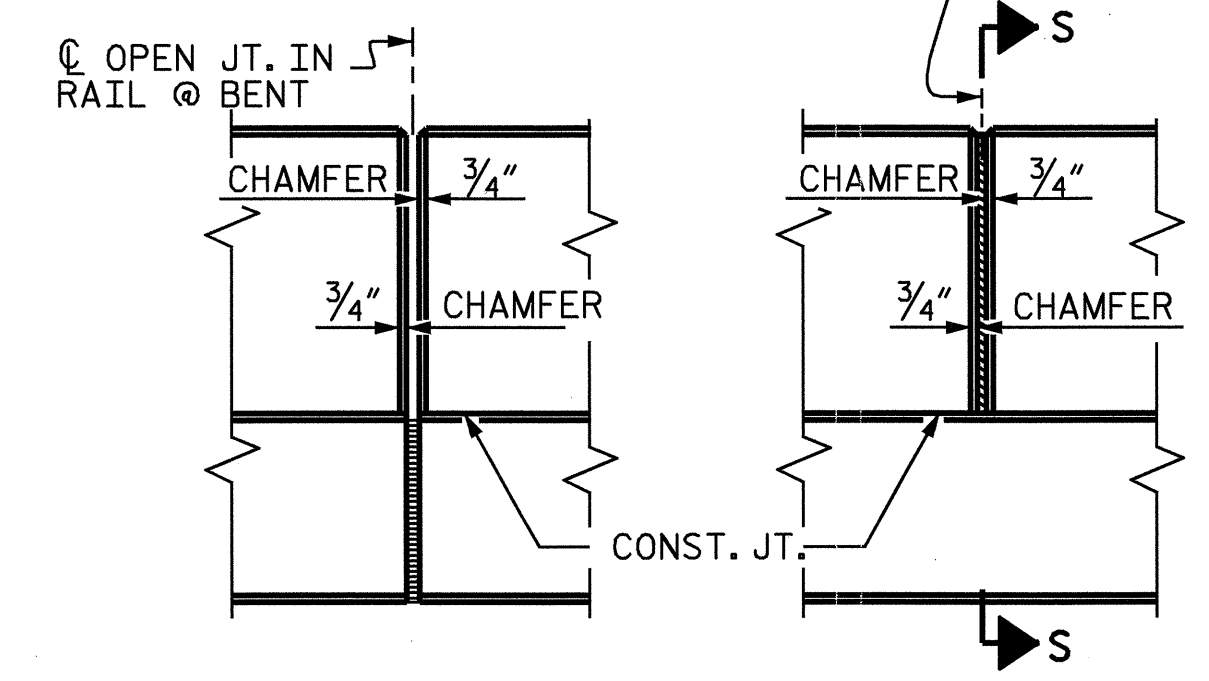

ELEVATION AT EXPANSION JOINTS

BARRIER RAIL DETAILS

DEAD LOAD DEFLECTION AND CAMBER		
	SPAN A	SPAN B
	1/2" Ø L.R. STRAND	1/2" Ø L.R. STRAND
CAMBER (SLAB ALONE IN PLACE)	2 3/8" ↑	2 1/8" ↑
DEFLECTION DUE TO SUPERIMPOSED DEAD LOAD**	7/16" ↓	5/16" ↓
FINAL CAMBER	1 5/16" ↑	1 13/16" ↑

** INCLUDES FUTURE WEARING SURFACE

CORED SLABS REQUIRED				
		NUMBER	LENGTH	TOTAL LENGTH
SPAN A	EXTERIOR C.S.	2	48'-9 3/4"	97'-7 1/2"
	INTERIOR C.S.	12	48'-9 3/4"	585'-9"
SPAN B	EXTERIOR C.S.	2	43'-9 3/4"	87'-7 1/2"
	INTERIOR C.S.	12	43'-9 3/4"	525'-9"
TOTAL		28		1296.75

GRADE 270 STRANDS	
	1/2" Ø L.R.
AREA (SQUARE INCHES)	0.153
ULTIMATE STRENGTH (LBS. PER STRAND)	41,300
APPLIED PRESTRESS (LBS. PER STRAND)	30,980

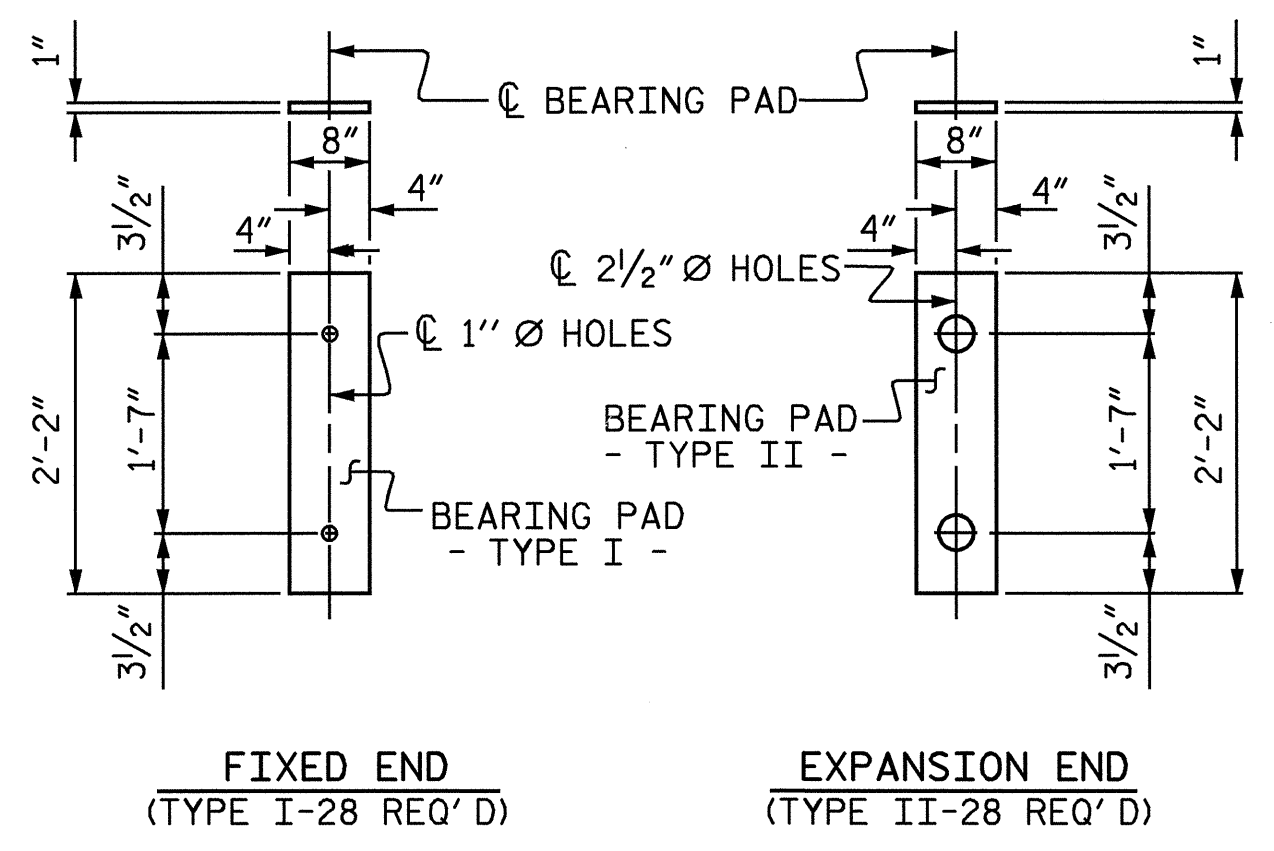

ELASTOMERIC BEARING DETAILS
(60 DUROMETER HARDNESS)

BAR TYPES

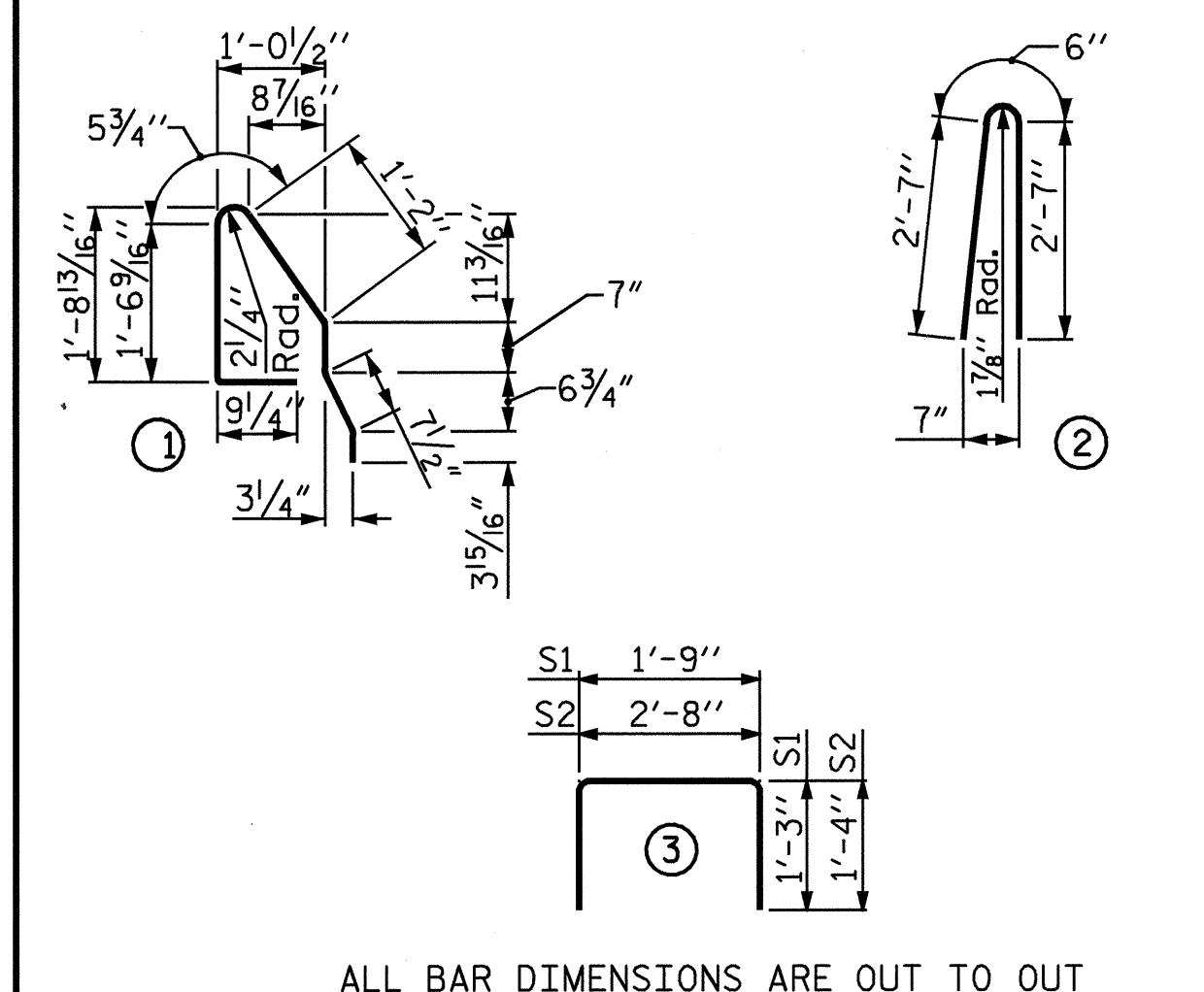

ALL BAR DIMENSIONS ARE OUT TO OUT

BILL OF MATERIAL FOR ONE CORED SLAB SECTION - SPAN A

BAR	NUMBER	SIZE	TYPE	EXTERIOR UNIT		INTERIOR UNIT	
				LENGTH	WEIGHT	LENGTH	WEIGHT
B1	4	# 4	STR	25'-6"	68	25'-6"	68
S1	8	# 5	3	4'-3"	35	4'-3"	35
S2	96	# 4	3	5'-4"	342		
S2	76	# 4	3			5'-4"	271
* S3	50	# 5	1	5'-6"	287		
REINFORCING STEEL				LBS.	445		374
* EPOXY COATED REINFORCING STEEL				LBS.	287		
5,000 P.S.I. CONCRETE				CU. YDS.	6.8		6.8
1/2" Ø L.R. STRANDS				No.	24		24

BILL OF MATERIAL FOR ONE CORED SLAB SECTION - SPAN B

BAR	NUMBER	SIZE	TYPE	EXTERIOR UNIT		INTERIOR UNIT	
				LENGTH	WEIGHT	LENGTH	WEIGHT
B3	4	# 4	STR	23'-0"	61	23'-0"	61
S1	8	# 5	3	4'-3"	35	4'-3"	35
S2	86	# 4	3	5'-4"	306		
S2	68	# 4	3			5'-4"	242
* S3	45	# 5	1	5'-6"	258		
REINFORCING STEEL				LBS.	402		338
* EPOXY COATED REINFORCING STEEL				LBS.	258		
5,000 P.S.I. CONCRETE				CU. YDS.	6.1		6.1
1/2" Ø L.R. STRANDS				No.	24		24

BILL OF MATERIAL FOR CONCRETE BARRIER RAIL

BAR	BARS PER SPAN		TOTAL NO.	SIZE	TYPE	LENGTH	WEIGHT
	SPAN A	SPAN B					
* B2	28		28	#5	STR	24'-0"	701
* B4		28	28	#5	STR	21'-6"	628
* S4	100	90	190	#5	2	5'-8"	1123
* EPOXY COATED REINFORCING STEEL				LBS.			2452
CLASS AA CONCRETE				CU. YDS.			21.4
TOTAL LIN. FT. OF CONCRETE BARRIER RAIL							185.25

NOTES

ALL PRESTRESSING STRANDS SHALL BE 7-WIRE LOW RELAXATION GRADE 270 STRANDS AND SHALL CONFORM TO AASHTO M203 EXCEPT FOR SAMPLING REQUIREMENTS WHICH SHALL BE IN ACCORDANCE WITH THE STANDARD SPECIFICATIONS.

ALL REINFORCING STEEL CAST WITH THE CORED SLAB SECTIONS SHALL BE GRADE 60 AND SHALL BE INCLUDED IN THE UNIT PRICE BID FOR PRESTRESSED CONCRETE CORED SLABS.

RECESSES FOR TRANSVERSE STRANDS SHALL BE GROUTED AFTER THE TENSIONING OF THE STRANDS.

THE 2 1/2" Ø DOWEL HOLES AT FIXED ENDS OF SLAB SECTIONS SHALL BE FILLED WITH GROUT. THE 2 1/2" Ø DOWEL HOLES AT EXPANSION ENDS OF SLAB SECTIONS SHALL BE FILLED WITH JOINT SEALER MATERIAL TO 1/2" ABOVE THE TOP OF DOWELS AND THEN FILLED WITH GROUT.

THE JOINT SEALER MATERIAL SHALL CONFORM TO THE REQUIREMENTS OF TYPE B LOW MODULUS SILICONE SEALANT. THE 2" Ø BACKER ROD SHALL CONFORM TO THE REQUIREMENTS OF TYPE M BOND BREAKER. THE 12" WIDE BOND BREAKING TAPE SHALL BE CENTERED OVER THE JOINT AND CONFORM TO THE REQUIREMENTS OF TYPE N BOND BREAKER. SEE SECTION 1028 OF THE STANDARD SPECIFICATIONS.

WHEN CORED SLABS ARE CAST, A POSITIVE HOLD-DOWN SYSTEM SHALL BE EMPLOYED TO PREVENT VOIDS FROM RISING OR MOVING SIDEWAYS. THIS SYSTEM SHALL BE DESIGNED TO BE LEFT IN PLACE UNTIL THE CONCRETE HAS REACHED RELEASE STRENGTH. AT LEAST THREE WEEKS PRIOR TO CASTING CORED SLABS, THE CONTRACTOR SHALL SUBMIT TO THE ENGINEER FOR REVIEW AND COMMENT, DETAILED DRAWINGS OF THE PROPOSED HOLD-DOWN SYSTEM. IN ADDITION TO STRUCTURAL DETAILS, LOCATION AND SPACING OF THE HOLD-DOWNS SHALL BE INDICATED.

THE TRANSFER OF LOAD FROM THE ANCHORAGES TO THE CORED SLAB UNIT SHALL BE DONE WHEN THE CONCRETE HAS REACHED A COMPRESSIVE STRENGTH OF NOT LESS THAN 4000 PSI.

ALL REINFORCING STEEL IN BARRIER RAILS SHALL BE EPOXY COATED.

PRESTRESSING STRANDS SHALL BE CUT FLUSH WITH THE CORED SLAB UNIT ENDS.

APPLY EPOXY PROTECTIVE COATING TO CORED SLAB UNIT ENDS. FOR EPOXY PROTECTIVE COATING, SEE SPECIAL PROVISIONS.

VERTICAL GROOVED CONTRACTION JOINTS, 1/2" IN DEPTH, SHALL BE TOOLED IN ALL EXPOSED FACES OF THE BARRIER RAIL AND IN ACCORDANCE WITH ARTICLE 825-10(B) OF THE STANDARD SPECIFICATIONS. A VERTICAL CONTRACTION JOINT SHALL BE LOCATED AT EACH THIRD POINT BETWEEN BARRIER RAIL EXPANSION JOINTS. ONLY ONE CONTRACTION JOINT IS REQUIRED AT MIDPOINT OF BARRIER RAIL SEGMENTS LESS THAN 20 FEET IN LENGTH AND NO CONTRACTION JOINTS ARE REQUIRED FOR THOSE SEGMENTS LESS THAN 10 FEET IN LENGTH.

FOR ELASTOMERIC BEARINGS, SEE SPECIAL PROVISIONS.

ALL ELASTOMERIC BEARING PADS SHALL BE 60 DUROMETER HARDNESS.

PROJECT NO. B-3871
MARTIN COUNTY
STATION: 16+67.50 -L-

SHEET 4 OF 4

STATE OF NORTH CAROLINA
DEPARTMENT OF TRANSPORTATION
RALEIGH

STANDARD
3'-0" X 1'-9"
PRESTRESSED
CONCRETE CORED
SLAB UNIT

OCTOBER 1981

NO.		BY:		DATE:		NO.		BY:		DATE:		SHEET NO.	
1						3						S-7	
2						4						TOTAL SHEETS 16	

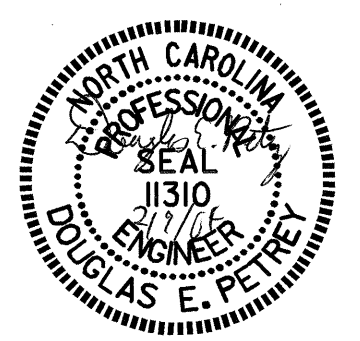

ASSEMBLED BY: R. G. EMERSON DATE: 7/03
CHECKED BY: P. C. BREWER DATE: 8/03
DRAWN BY: WJH 4/89 REV. 10/17/00 RWW/LES
CHECKED BY: FCJ 5/89 REV. 7/10/01 RWW/LES
REV. 5/7/03 RWW/JTE