

NOTES

ALL PRESTRESSING STRANDS SHALL BE 7-WIRE LOW-RELAXATION GRADE 270 STRANDS AND SHALL CONFORM TO AASHTO M203 EXCEPT FOR SAMPLING REQUIREMENTS WHICH SHALL BE IN ACCORDANCE WITH THE STANDARD SPECIFICATIONS.

TIE ROD ASSEMBLY SHALL BE AASHTO M270 GRADE 36 STRUCTURAL STEEL.

ALL REINFORCING STEEL SHALL BE GRADE 60.

APPLY EPOXY PROTECTIVE COATING TO END OF GIRDER SURFACES INDICATED IN ELEVATION VIEW. FOR EPOXY PROTECTIVE COATING, SEE SPECIAL PROVISIONS.

EMBEDDED PLATE "B-1" SHALL BE GALVANIZED IN ACCORDANCE WITH THE STANDARD SPECIFICATIONS. BEVEL EDGES OF PLATE "B-1" TO GIVE CLOSE FIT BUT NOT TIGHT FIT TO STEEL CASTING FORM.

ANCHOR STUDS SHALL CONFORM TO AASHTO M169 GRADES 1010 THROUGH 1020 OR APPROVED EQUAL, AND SHALL MEET THE TYPE "B" REQUIREMENTS OF SUBSECTION 7.3 OF THE ANSI/AASHTO/AWS D1.5 BRIDGE WELDING CODE.

AT ENDS OF GIRDERS TO BE EMBEDDED IN CONCRETE DIAPHRAGMS OR END WALLS, PRESTRESSING STRANDS MAY EXTEND A MAXIMUM OF 2" BEYOND THE GIRDER ENDS. OTHERWISE, PRESTRESSING STRANDS SHALL BE CUT FLUSH WITH THE GIRDER ENDS.

THE TRANSFER OF LOAD FROM THE ANCHORAGES TO THE GIRDER SHALL BE DONE WHEN CONCRETE HAS REACHED A COMPRESSIVE STRENGTH OF NOT LESS THAN 4000 PSI FOR SPAN A AND 4800 PSI FOR SPANS B THROUGH SPAN D.

DEPENDING ON THE TYPE OF SYSTEM USED TO SUPPORT THE DECK SLAB FORMS, PRESET ANCHORS MAY BE NECESSARY IN THE PRESTRESSED CONCRETE GIRDER.

THE TOP SURFACE OF THE GIRDER, EXCLUDING THE OUTSIDE 4", SHALL BE RAKED TO A DEPTH OF 1/4".

WHEN DRAPED STRANDS ARE DETAILED, THE LONGITUDINAL LOCATION OF THE HOLD DOWN DEVICES SHALL BE WITHIN 6" OF THE LOCATION SHOWN AND THE CENTER OF GRAVITY OF THE GROUP OF DRAPED STRANDS SHALL BE LOCATED WITHIN 1/2" OF THE THEORETICAL LOCATION SHOWN.

FOR VERTICAL CRACKS IN PRESTRESSED CONCRETE GIRDERS PRIOR TO DETENSIONING, SEE SPECIAL PROVISIONS.

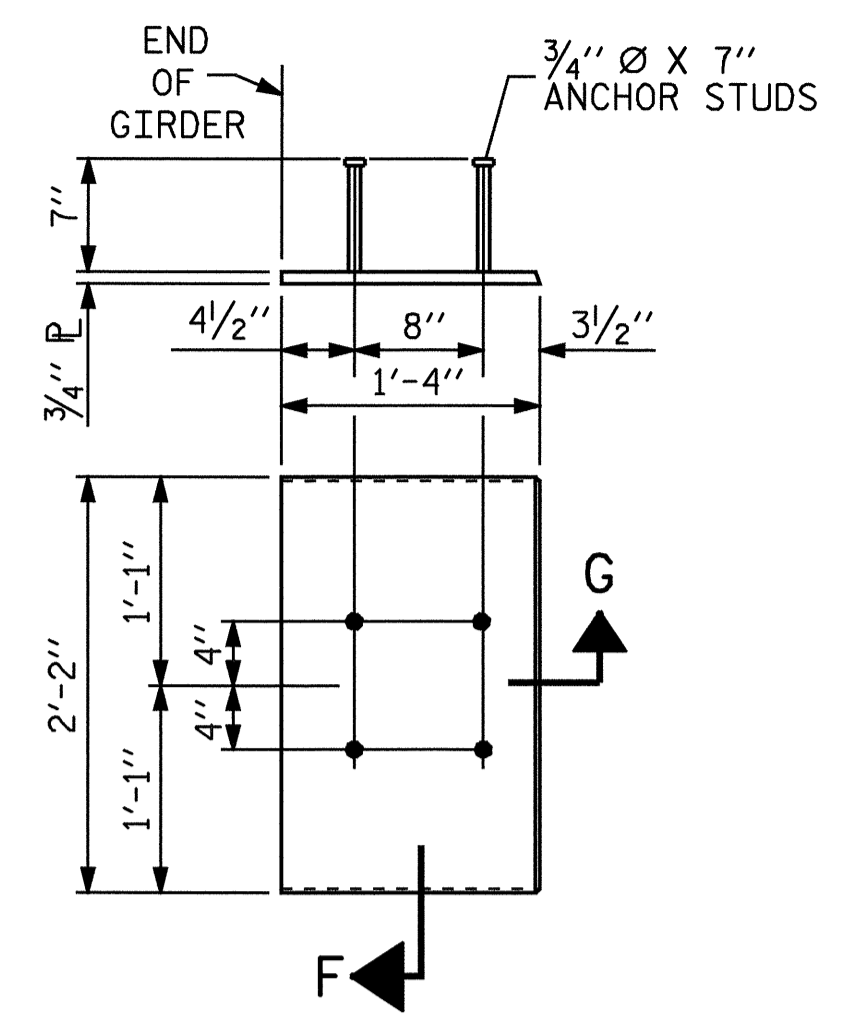

EMBEDDED PLATE "B-1" DETAILS FOR AASHTO TYPE IV GIRDER
(2 REQ'D PER GIRDER)

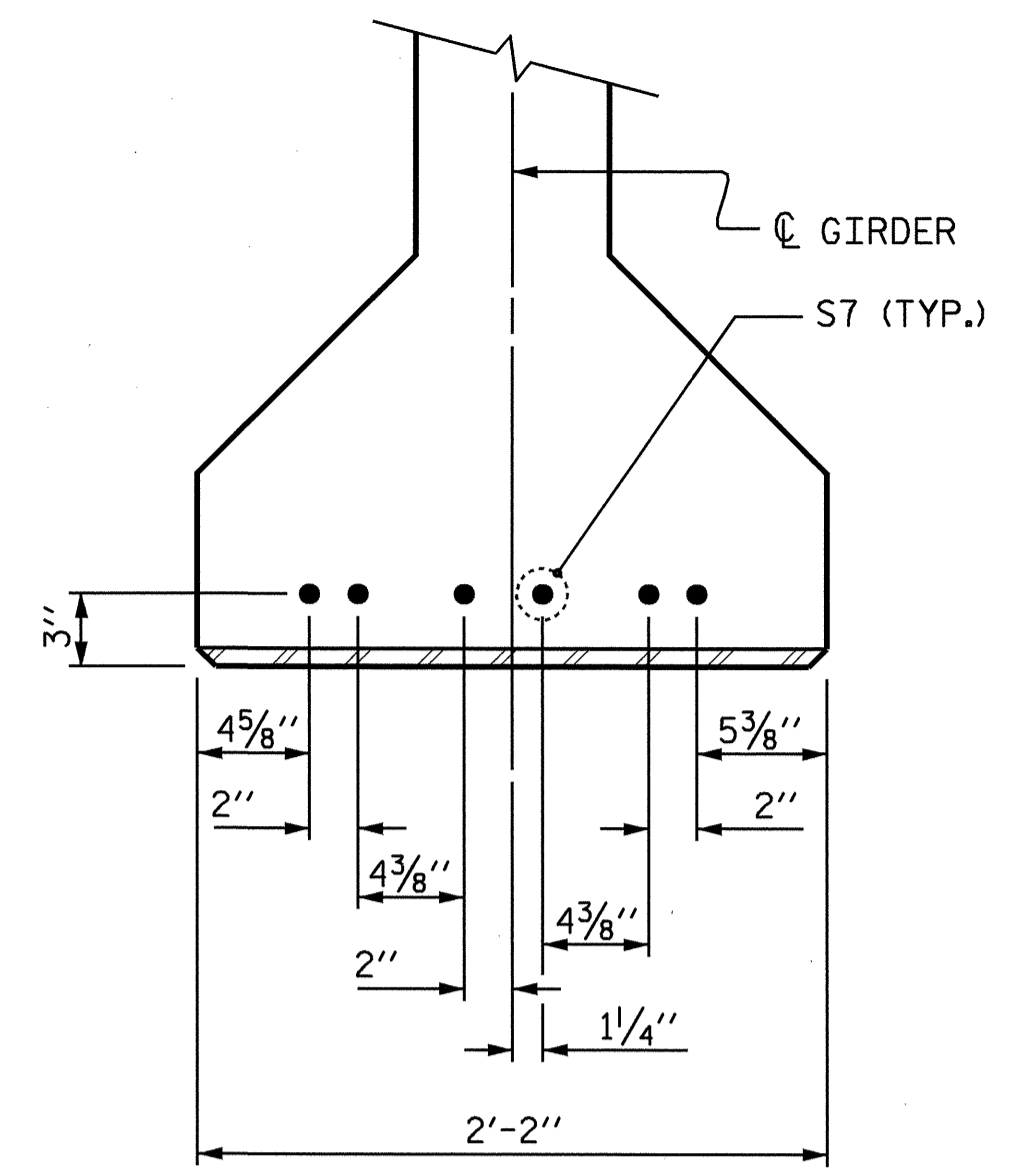

DETAIL "A"
(FOR AASHTO TYPE IV GIRDERS)

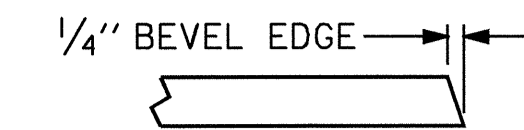

SECTION "G"

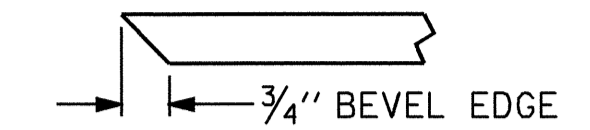

SECTION "F"
(SEE NOTES)

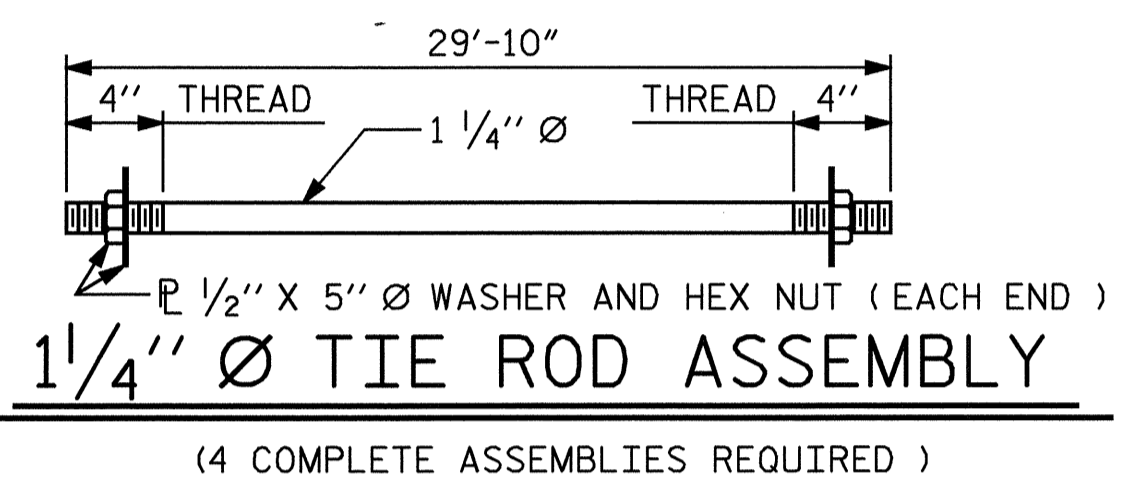

1 1/4" Ø TIE ROD ASSEMBLY
(4 COMPLETE ASSEMBLIES REQUIRED)

DEAD LOAD DEFLECTION TABLE FOR SPAN A																																	
1/2" LOW RELAXATION TENTH POINTS	GIRDER 1											GIRDER 2 & 3								GIRDER 4													
	0	.1	.2	.3	.4	.5	.6	.7	.8	.9	0	0	.1	.2	.3	.4	.5	.6	.7	.8	.9	0	0	.1	.2	.3	.4	.5	.6	.7	.8	.9	0
CAMBER (GIRDER ALONE IN PLACE)	0.0	0.017	0.033	0.045	0.052	0.055	0.052	0.045	0.033	0.017	0.0	0.0	0.017	0.033	0.045	0.052	0.055	0.052	0.045	0.033	0.017	0.0	0.0	0.017	0.033	0.045	0.052	0.055	0.052	0.045	0.033	0.017	0.0
* DEFLECTION DUE TO SUPERIMPOSED D.L.	0.0	0.008	0.015	0.020	0.023	0.025	0.023	0.020	0.015	0.008	0.0	0.0	0.009	0.016	0.022	0.026	0.027	0.026	0.022	0.016	0.009	0.0	0.0	0.008	0.015	0.020	0.023	0.025	0.023	0.020	0.015	0.008	0.0
FINAL CAMBER	0.0	1/8"	3/16"	5/16"	3/8"	3/8"	3/8"	5/16"	3/16"	1/8"	0.0	0.0	1/8"	3/16"	1/4"	5/16"	5/16"	5/16"	1/4"	3/16"	1/8"	0.0	0.0	1/8"	3/16"	5/16"	3/8"	3/8"	3/8"	5/16"	3/16"	1/8"	0.0

DEAD LOAD DEFLECTION TABLE FOR SPAN B,C & D																																	
1/2" LOW RELAXATION TENTH POINTS	GIRDER 1											GIRDER 2 & 3								GIRDER 4													
	0	.1	.2	.3	.4	.5	.6	.7	.8	.9	0	0	.1	.2	.3	.4	.5	.6	.7	.8	.9	0	0	.1	.2	.3	.4	.5	.6	.7	.8	.9	0
CAMBER (GIRDER ALONE IN PLACE)	0.0	0.093	0.176	0.241	0.282	0.296	0.282	0.241	0.176	0.093	0.0	0.0	0.093	0.176	0.241	0.282	0.296	0.282	0.241	0.176	0.093	0.0	0.0	0.093	0.176	0.241	0.282	0.296	0.282	0.241	0.176	0.093	0.0
* DEFLECTION DUE TO SUPERIMPOSED D.L.	0.0	0.036	0.069	0.094	0.111	0.116	0.111	0.094	0.069	0.036	0.0	0.0	0.041	0.077	0.106	0.124	0.130	0.124	0.106	0.077	0.041	0.0	0.0	0.036	0.069	0.094	0.111	0.116	0.111	0.094	0.069	0.036	0.0
FINAL CAMBER	0.0	1 1/16"	1 5/16"	1 3/4"	2 1/16"	2 3/8"	2 1/16"	1 3/4"	1 5/16"	1 1/16"	0.0	0.0	5/8"	1 3/16"	1 5/8"	1 15/16"	2 "	1 15/16"	1 5/8"	1 3/16"	5/8"	0.0	0.0	1 1/16"	1 5/16"	1 3/4"	2 1/16"	2 3/16"	2 1/16"	1 3/4"	1 5/16"	1 1/16"	0.0

* INCLUDES FUTURE WEARING SURFACE
ALL VALUES ARE SHOWN IN FEET (DECIMAL FORM), EXCEPT "FINAL CAMBER", WHICH IS GIVEN IN INCHES (FRACTION FORM).

PROJECT NO. B-3865
JOHNSTON COUNTY
STATION: 21+48.00 -L-

SHEET 4 OF 4

STATE OF NORTH CAROLINA
DEPARTMENT OF TRANSPORTATION
RALEIGH
STANDARD
PRESTRESSED CONCRETE GIRDER
CONTINUOUS FOR LIVE LOAD
DETAILS

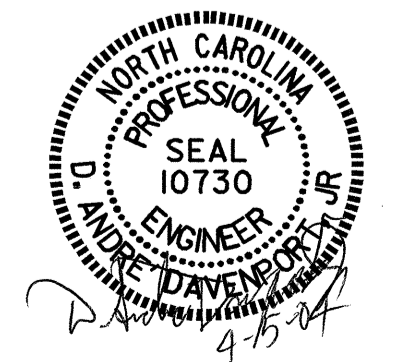

REVISIONS						SHEET NO. S-14
NO.	BY:	DATE:	NO.	BY:	DATE:	
1			3			TOTAL SHEETS 33
2			4			

ASSEMBLED BY : H. TOM BARBOUR	DATE : 3-26-03
CHECKED BY : D. G. ELY	DATE : 5-03
DRAWN BY : ELR 11/91	REV. 8/16/99 MAB/LES
CHECKED BY : GRP 11/91	REV. 10/17/00 RWW/LES
	REV. 7/10/01 LES/RDR