

SECTION N-N

SEE SHEET 1 OF 4 FOR SECTION LOCATIONS

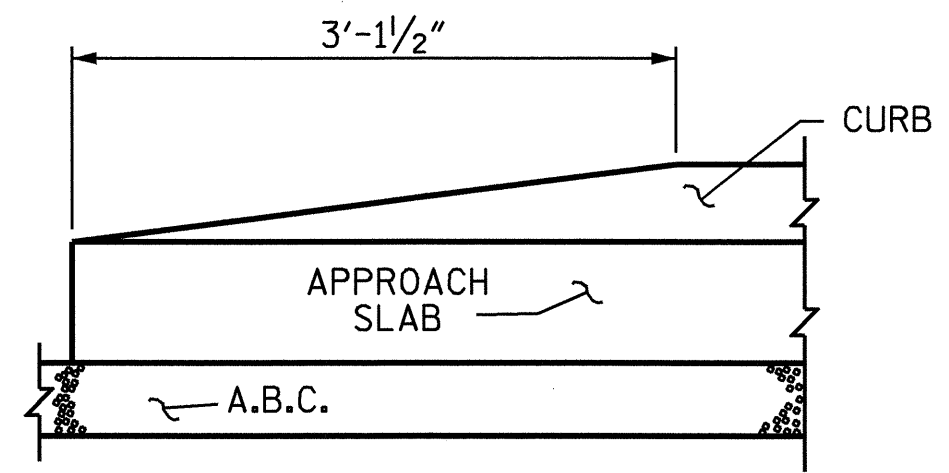

END OF CURB WITHOUT SHOULDER BERM GUTTER

CURB DETAILS

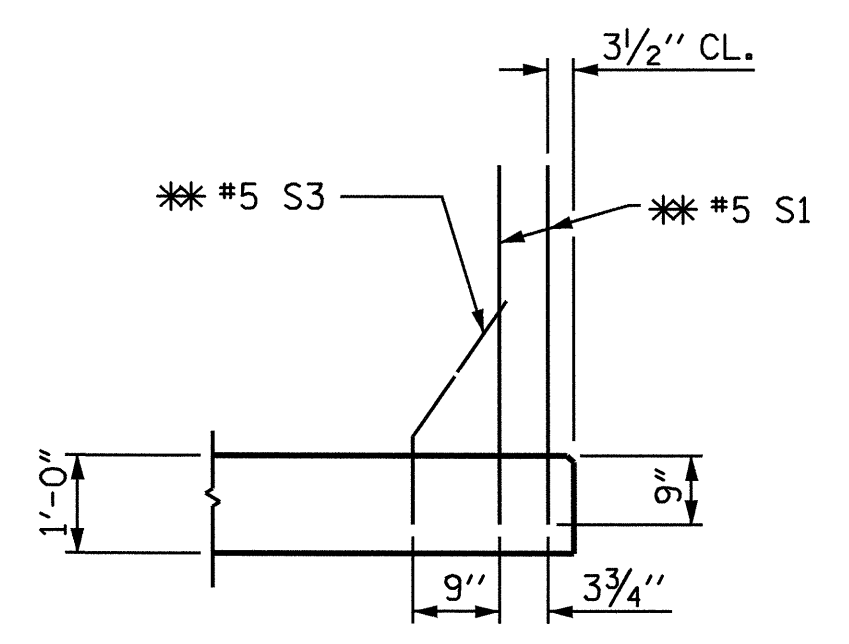

SECTION K-K
** ADHESIVELY ANCHORED

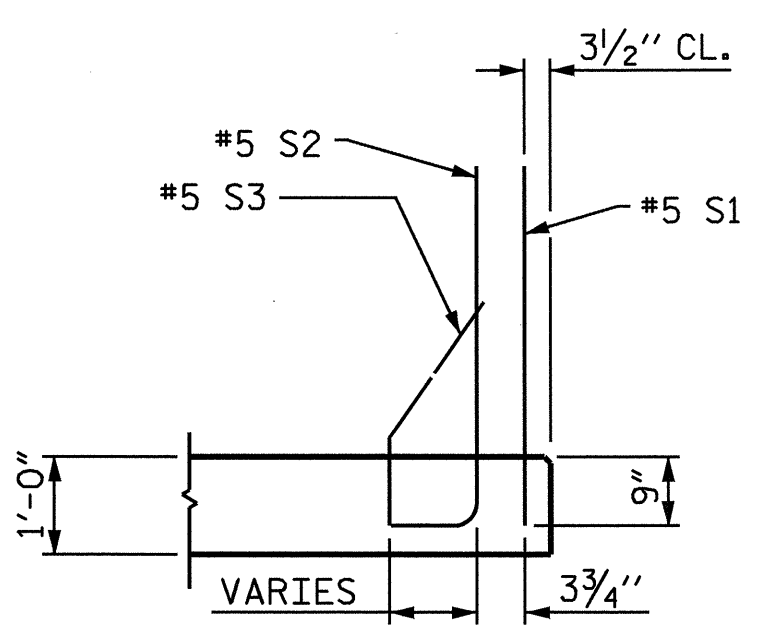

SECTION L-L

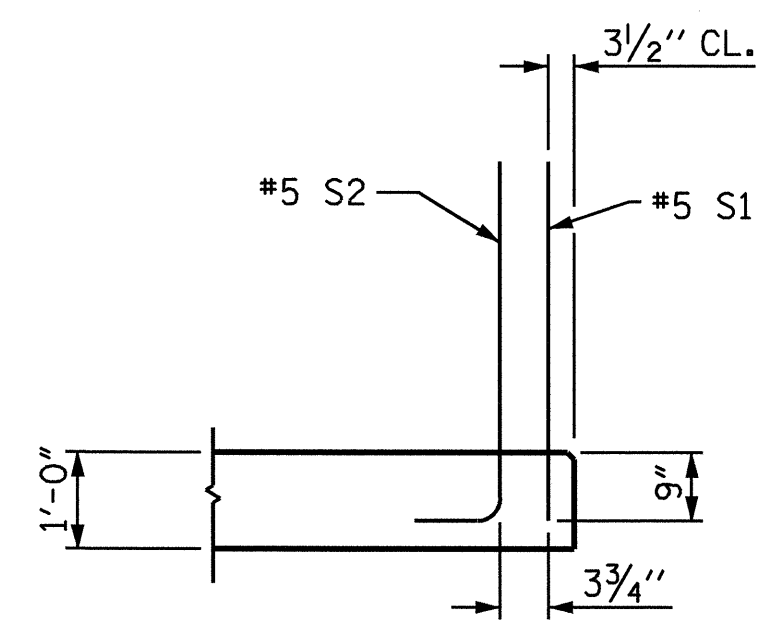

SECTION M-M

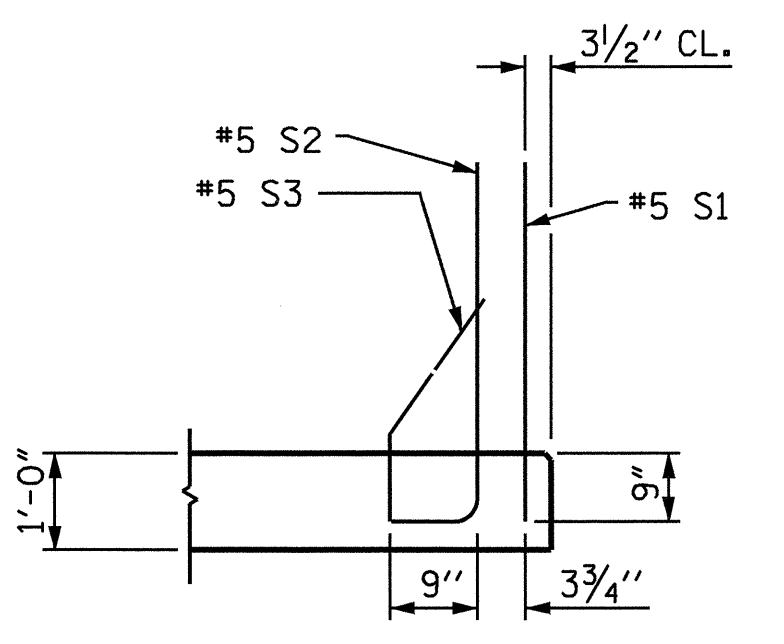

SECTION P-P

NOTES

THE COST OF THE BARRIER RAIL ON THE APPROACH SLAB SHALL BE INCLUDED IN THE LUMP SUM CONTRACT PRICE BID FOR BRIDGE APPROACH SLABS.

APPROACH SLAB SHALL NOT BE CONSTRUCTED PRIOR TO COMPLETION OF THE BRIDGE DECK.

FOR REINFORCED BRIDGE APPROACH FILL INCLUDING FABRIC, IMPERMEABLE GEOMEMBRANE, 4" Ø DRAINAGE PIPE, #78M STONE, AND SELECT MATERIAL, SEE ROADWAY PLANS.

TEMPORARY DRAINAGE AND TEMPORARY BERM AND SLOPE DRAINS WILL BE PAID FOR UNDER THE LUMP SUM PRICE FOR BRIDGE APPROACH SLAB.

AREA BETWEEN THE WINGWALL AND APPROACH SLAB SHALL BE GRADED TO DRAIN THE WATER AWAY FROM THE FILL FACE OF THE BRIDGE.

THE 6" COMP. A.B.C. SHALL EXTEND 10'-0" BEYOND THE END OF THE APPROACH SLAB AND 1'-0" OUTSIDE OF EACH EDGE OF THE SLAB.

THE CONTRACTOR MAY USE 4" TYPE B-25.0B ASPHALT CONCRETE BASE COURSE IN LIEU OF 6" COMP. A.B.C. IF THIS OPTION IS USED, THE BASE COURSE SHALL EXTEND 1'-0" BEYOND THE END OF THE APPROACH SLAB AND THE WIDTH SHALL BE THE SAME AS THAT OF THE APPROACH SLAB.

THE CONTRACTOR MAY USE 5" CLASS "A" CONCRETE BASE IN LIEU OF 6" COMP. A.B.C. IF THIS OPTION IS USED, THE CONCRETE BASE SHALL EXTEND 1'-0" BEYOND THE END OF THE APPROACH SLAB AND THE WIDTH SHALL BE THE SAME AS THAT OF THE APPROACH SLAB. THE CONCRETE SHALL BE FINISHED TO A SMOOTH SURFACE AND A LAYER OF 30 LB ROOFING FELT SHALL BE PLACED BETWEEN THE CONCRETE BASE AND THE APPROACH SLAB TO PREVENT BOND. THE APPROACH SLAB SHALL NOT BE CAST UNTIL THE CONCRETE BASE HAS REACHED AN AGE OF THREE CURING DAYS.

THE JOINT SHALL BE SAWED PRIOR TO THE CASTING OF THE BARRIER RAIL.

WITH EVAZOTE JOINT SEAL

FOR EVAZOTE JOINT SEALS, SEE SPECIAL PROVISIONS.

THE NOMINAL UNCOMPRESSED SEAL WIDTH OF THE EVAZOTE JOINT SEAL SHALL BE 2 13/16".

BILL OF MATERIAL

FOR ONE APPROACH SLAB (2 REQ'D)

BAR	NO.	SIZE	TYPE	LENGTH	WEIGHT
*A1	25	#5	STR	53'-2"	1386
*A2	24	#5	STR	53'-5"	1337
A3	98	#4	STR	27'-7"	1806
*B1	107	#6	STR	24'-3"	3897
B2	107	#8	STR	24'-8"	7047
*B3	8	#5	STR	24'-8"	206
*B4	7	#5	STR	11'-8"	85
*B5	1	#5	3	6'-4"	7
*S1	58	#5	STR	3'-3"	197
*S2	42	#5	1	4'-1"	179
*S3	36	#5	2	2'-3"	84

REINFORCING STEEL	LBS.	8853
*EPOXY COATED REINFORCING STEEL	LBS.	7378

CLASS AA CONCRETE BREAKDOWN

POUR 1 SLAB & CURB	C. Y.	50.1
POUR 2 RAIL	C. Y.	3.6

CLASS AA CONCRETE	C. Y.	53.7
-------------------	-------	------

BAR TYPES

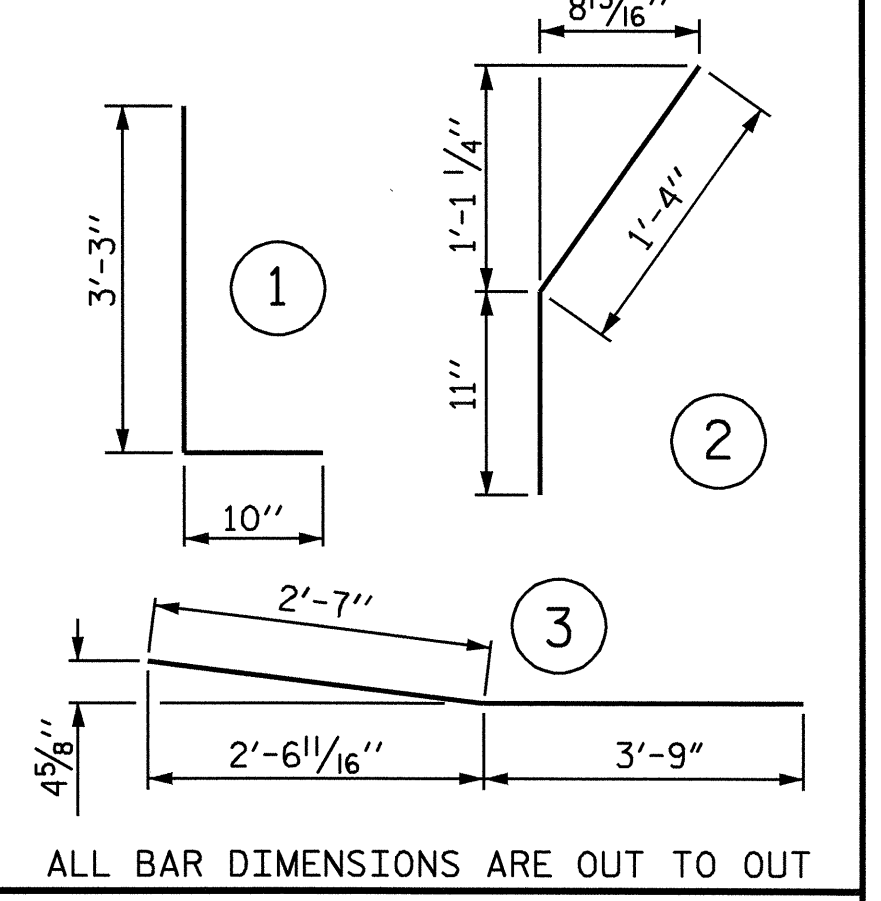

ALL BAR DIMENSIONS ARE OUT TO OUT

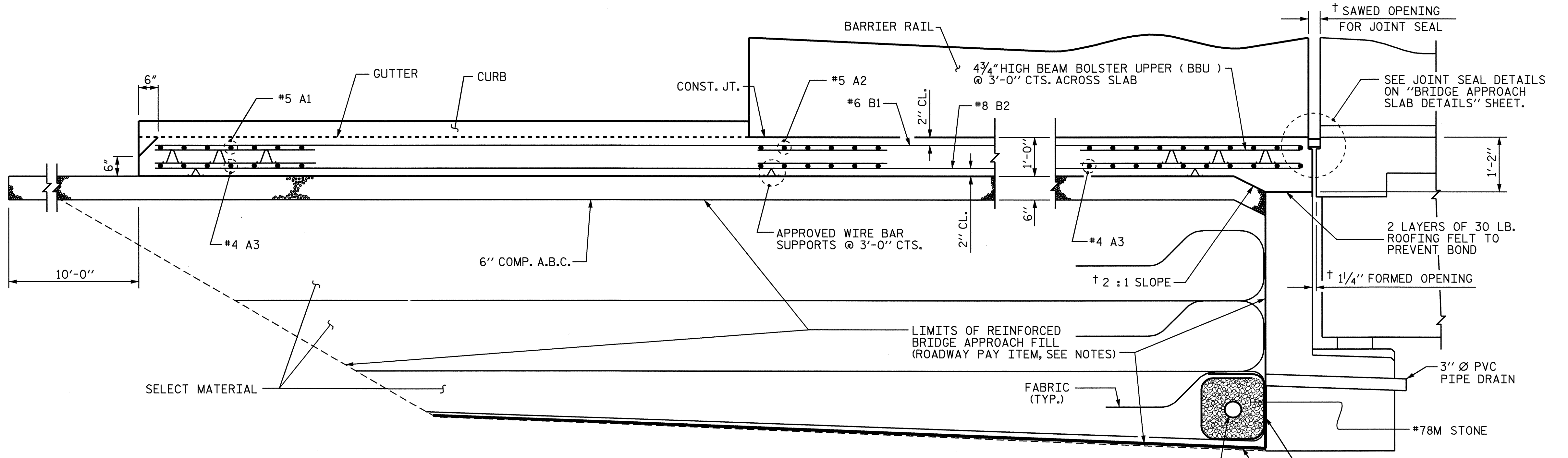

SECTION THRU SLAB

RIGHT SIDE OF RAIL NOT SHOWN

PROJECT NO. B-3157
DAVIDSON COUNTY
STATION: 29+25.37 -L-

SHEET 2 OF 4

STATE OF NORTH CAROLINA
DEPARTMENT OF TRANSPORTATION
RALEIGH
BRIDGE APPROACH SLAB
FOR RIGID PAVEMENT
WITH BARRIER RAIL
LEFT LANE



REVISIONS				SHEET NO.
NO.	BY:	DATE:	NO.	DATE:
1			3	
2			4	

ASSEMBLED BY : T.L. AVERETTE	DATE : 06-04
CHECKED BY : P. ADKINS	DATE : 06-04
DRAWN BY : LES 8/01	REV. 5/7/03 RWW/JTE
CHECKED BY : RDR 8/01	