

NOTES

THE BARRIER RAIL IN EACH SPAN SHALL NOT BE CAST UNTIL ALL SLAB CONCRETE IN THAT SPAN HAS BEEN CAST AND HAS REACHED A MINIMUM COMPRESSIVE STRENGTH OF 3,000 PSI.

WHEN COMPRESSION JOINT SEAL OR EVAZOTE JOINT SEAL IS REQUIRED, THE JOINT IN THE DECK SHALL BE SAWED PRIOR TO THE CASTING OF BARRIER RAIL.

ALL REINFORCING STEEL IN BARRIER RAILS SHALL BE EPOXY COATED.

THE #5 S3 AND #5 S4 BARS SHALL BE INSTALLED, USING AN ADHESIVE ANCHORING SYSTEM, AFTER SAWING THE JOINT. FOR ADHESIVELY ANCHORED ANCHOR BOLTS OR DOWELS, SEE SPECIAL PROVISIONS. THE YIELD LOAD FOR THE #5 S3 AND #5 S4 BARS IS 18.6 KIPS. FIELD TESTING FOR THE ADHESIVE BONDING SYSTEM IS NOT REQUIRED.

VERTICAL GROOVED CONTRACTION JOINTS, 1/2" IN DEPTH, SHALL BE TOOLED IN ALL EXPOSED FACES OF THE BARRIER RAIL AND IN ACCORDANCE WITH ARTICLE 825-10(B) OF THE STANDARD SPECIFICATIONS. THE CONTRACTION JOINT SHALL BE LOCATED AT EACH THIRD POINT BETWEEN BARRIER RAIL EXPANSION JOINTS. ONLY ONE CONTRACTION JOINT IS REQUIRED AT MIDPOINT OF BARRIER RAIL SEGMENTS LESS THAN 20 FEET IN LENGTH AND NO CONTRACTION JOINTS ARE REQUIRED FOR THOSE SEGMENTS LESS THAN 10 FEET IN LENGTH.

BAR TYPES

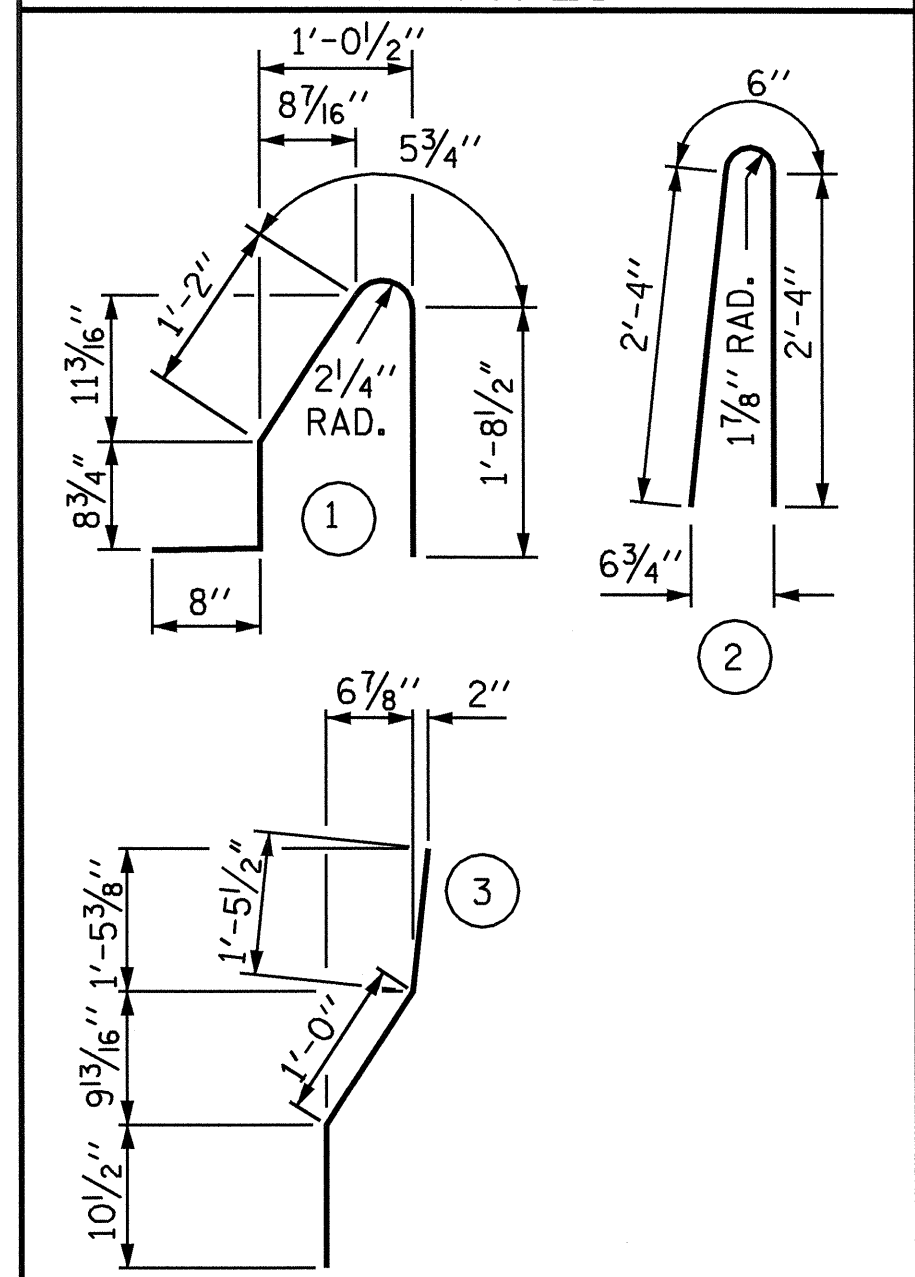

ALL BAR DIMENSIONS ARE OUT TO OUT

BILL OF MATERIAL

FOR CONCRETE BARRIER RAIL ONLY

BAR NO.	NO.	SIZE	TYPE	LENGTH	WEIGHT
* B1	70	#5	STR	26'-9"	1953
* S1	262	#5	1	4'-9"	1298
* S2	262	#5	2	5'-2"	1412
* S3	12	#5	3	3'-4"	42
* S4	12	#5	STR	3'-2"	40
* EPOXY COATED REINFORCING STEEL					4745 LBS.
CLASS AA CONCRETE					27.2 CU. YDS.
CONCRETE BARRIER RAIL					271.98 LIN. FT.

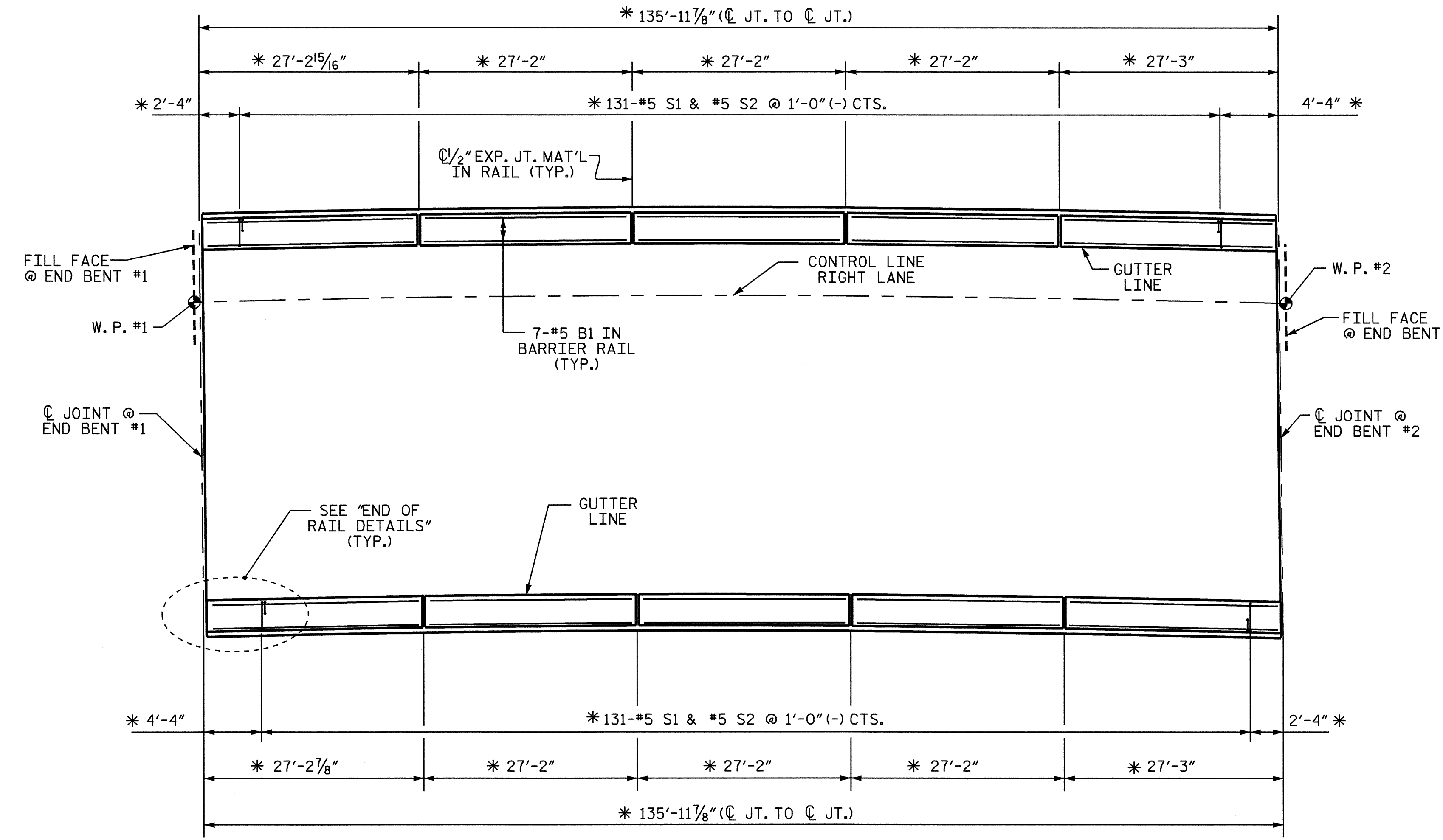

PLAN OF BARRIER RAIL

* ARC DIMENSION ALONG OUTSIDE EDGE OF SUPERSTRUCTURE

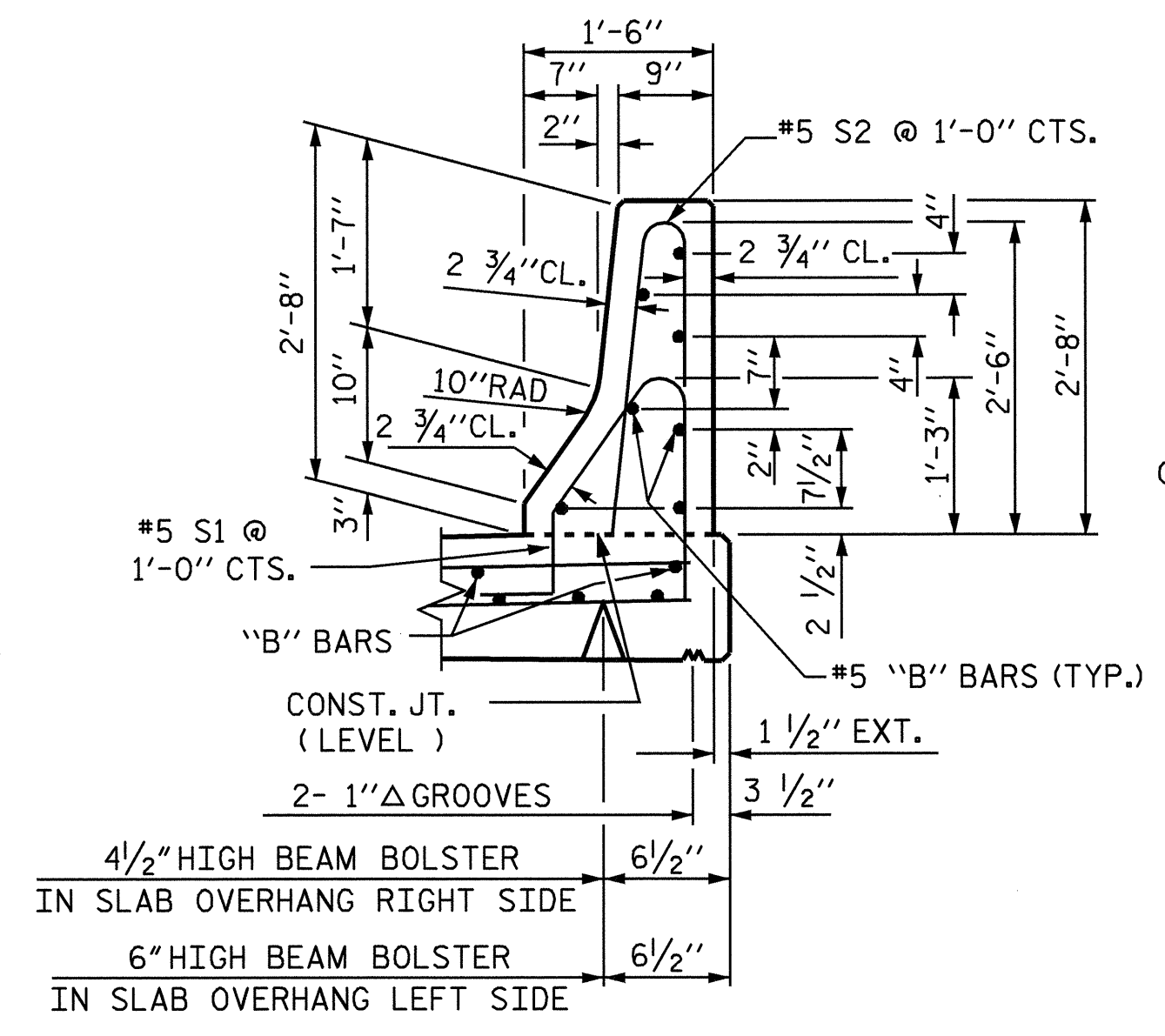

SECTION THRU RAIL

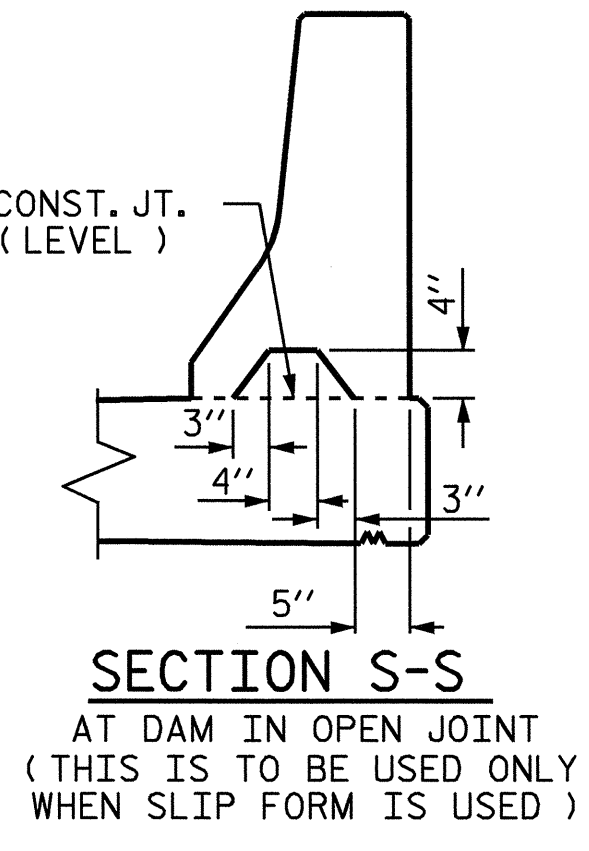

SECTION S-S

AT DAM IN OPEN JOINT (THIS IS TO BE USED ONLY WHEN SLIP FORM IS USED)

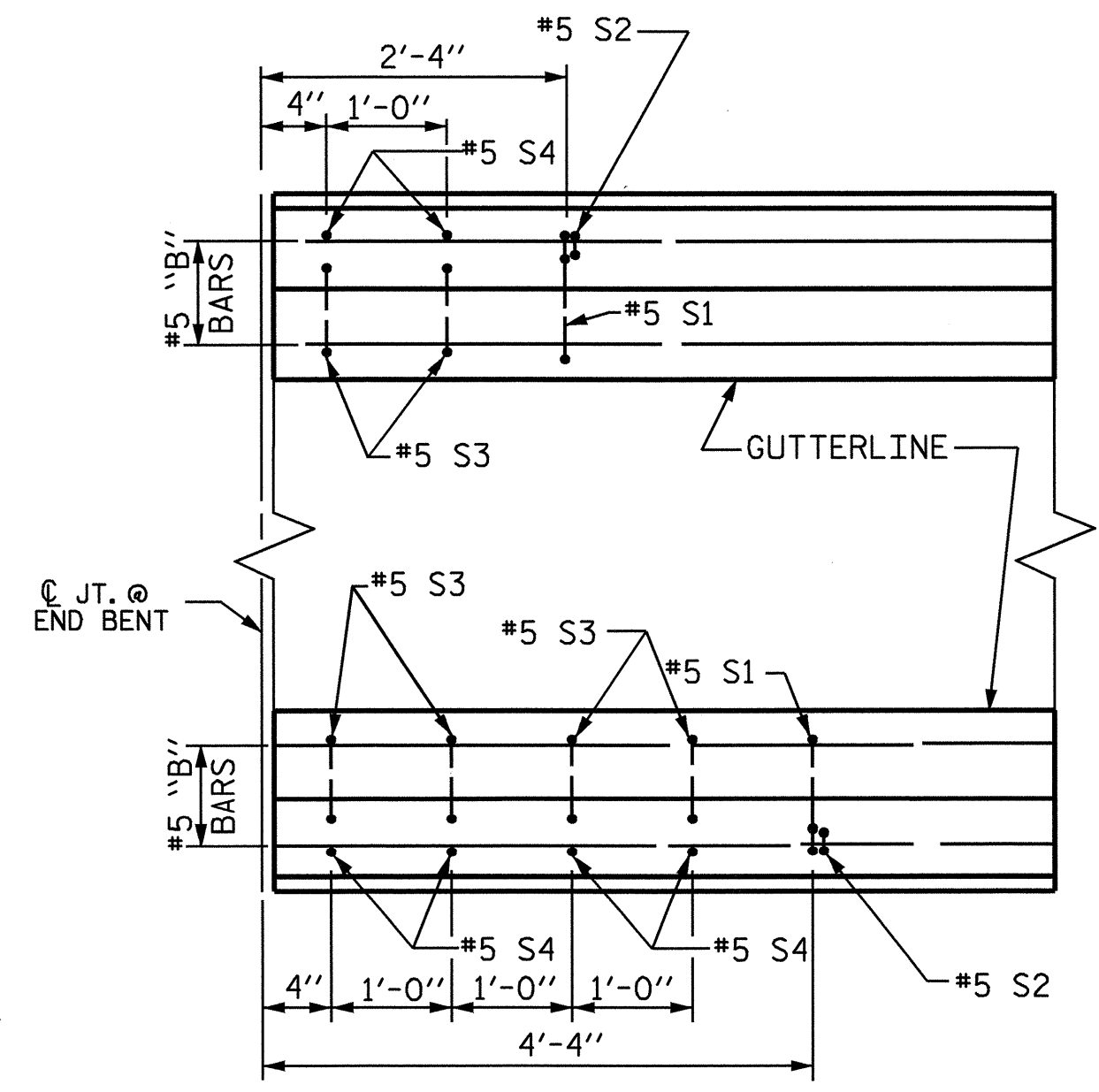

PLAN

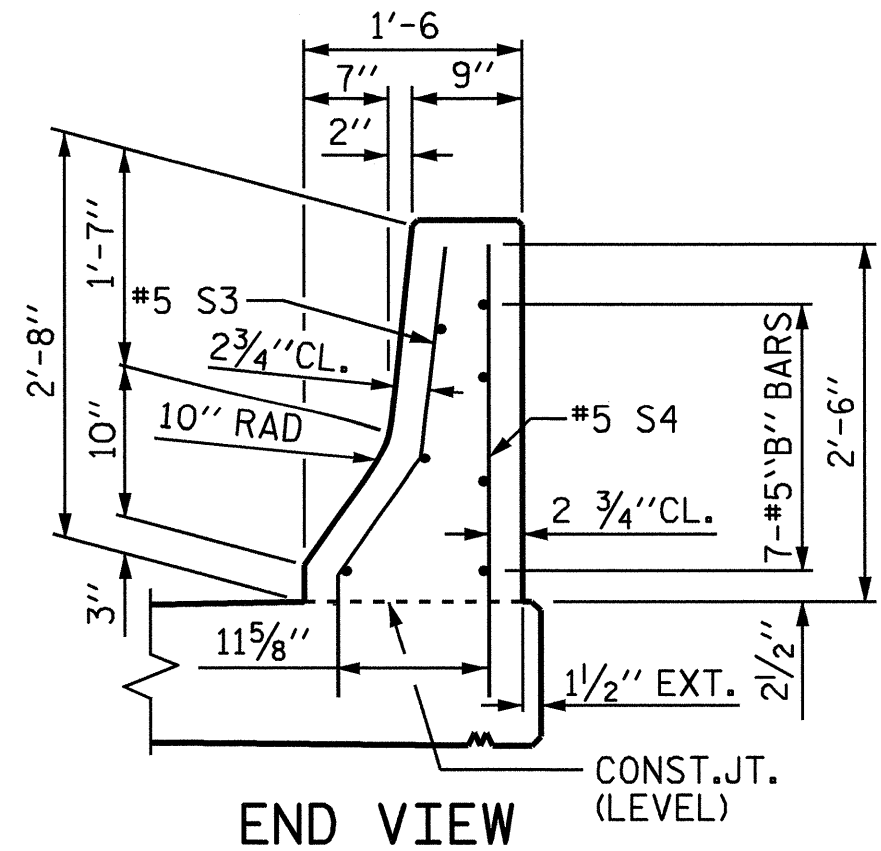

END VIEW

1/2" EXP. JT. MAT'L HELD IN PLACE WITH GALVANIZED NAILS.
 (NOTE: OMIT EXP. JT. MAT'L. WHEN SLIP FORM IS USED.)

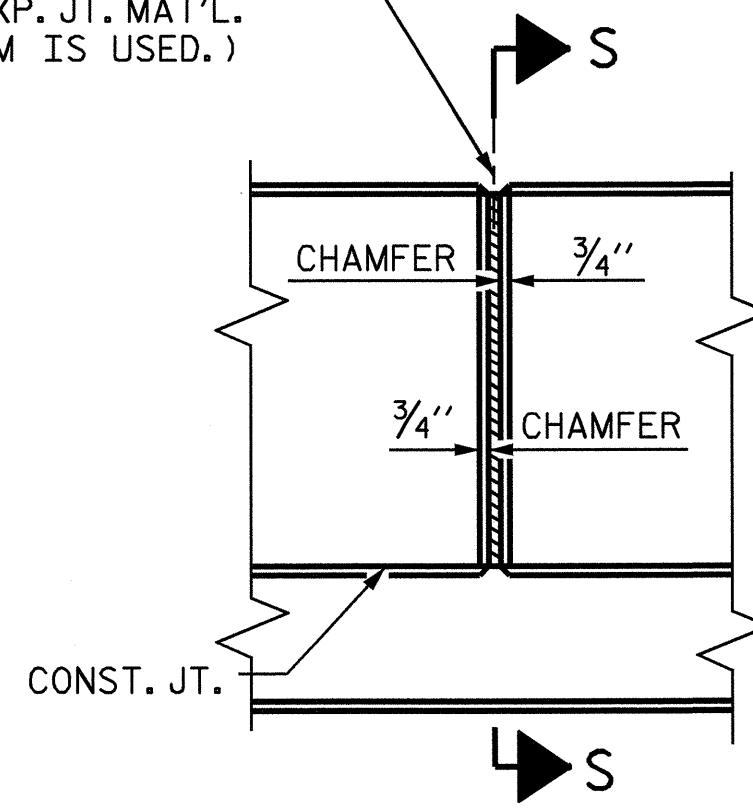

ELEVATION AT EXPANSION JOINTS

BARRIER RAIL DETAILS



Emily E. Murrey
 6/29/04

PROJECT NO. B-3157
DAVIDSON COUNTY
 STATION: 29+25.37 -L-

STATE OF NORTH CAROLINA
 DEPARTMENT OF TRANSPORTATION
 RALEIGH

STANDARD CONCRETE BARRIER RAIL

OCTOBER RIGHT LANE 1987

REVISIONS						SHEET NO.	
NO.	BY:	DATE:	NO.	BY:	DATE:	S-44	
1			3			TOTAL SHEETS 56	
2			4				

ASSEMBLED BY : PEGGY ADKINS DATE : 4-03
 CHECKED BY : M. M. PARSONS DATE : 5-03

DRAWN BY : ARB 5/87 REV. 8/16/99 RWW/LES
 CHECKED BY : SJD 9/87 REV. 10/17/00 RWW/LES
 REV. 5/7/03R RWW/JTE

END OF RAIL DETAILS

FOR ADHESIVE ANCHORING AT SAWED JOINTS