

NOTES

STIRRUPS IN CAP MAY BE SHIFTED AS NECESSARY TO CLEAR ANCHOR BOLTS.

FOR EPOXY PROTECTIVE COATING, SEE SPECIAL PROVISIONS.

PIPE DRAINS MAY BE SHIFTED SLIGHTLY AS NECESSARY TO CLEAR REINFORCING STEEL AND ANCHOR BOLTS.

BACKWALL SHALL BE PLACED BEFORE APPLYING THE EPOXY PROTECTIVE COATING.

THE TOP SURFACE AREAS OF THE END BENT CAPS SHALL BE CURED IN ACCORDANCE WITH THE STANDARD SPECIFICATIONS EXCEPT THAT THE MEMBRANE CURING COMPOUND METHOD SHALL NOT BE USED.

THE TOP SURFACE OF THE CAP EXCEPT THE BRIDGE SEAT BUILDUPS SHALL BE SLOPED TRANSVERSELY FROM THE FILL FACE TO THE BACK FACE AT THE RATE OF 2%.

REINFORCING STEEL SHOWN EXTENDING PAST CONSTRUCTION JOINT MUST EXTEND EXTRA LENGTH FOR SPLICE TO BE SKEWED. MATCHING BARS IN RIGHT LANE ARE MINIMUM LENGTH.

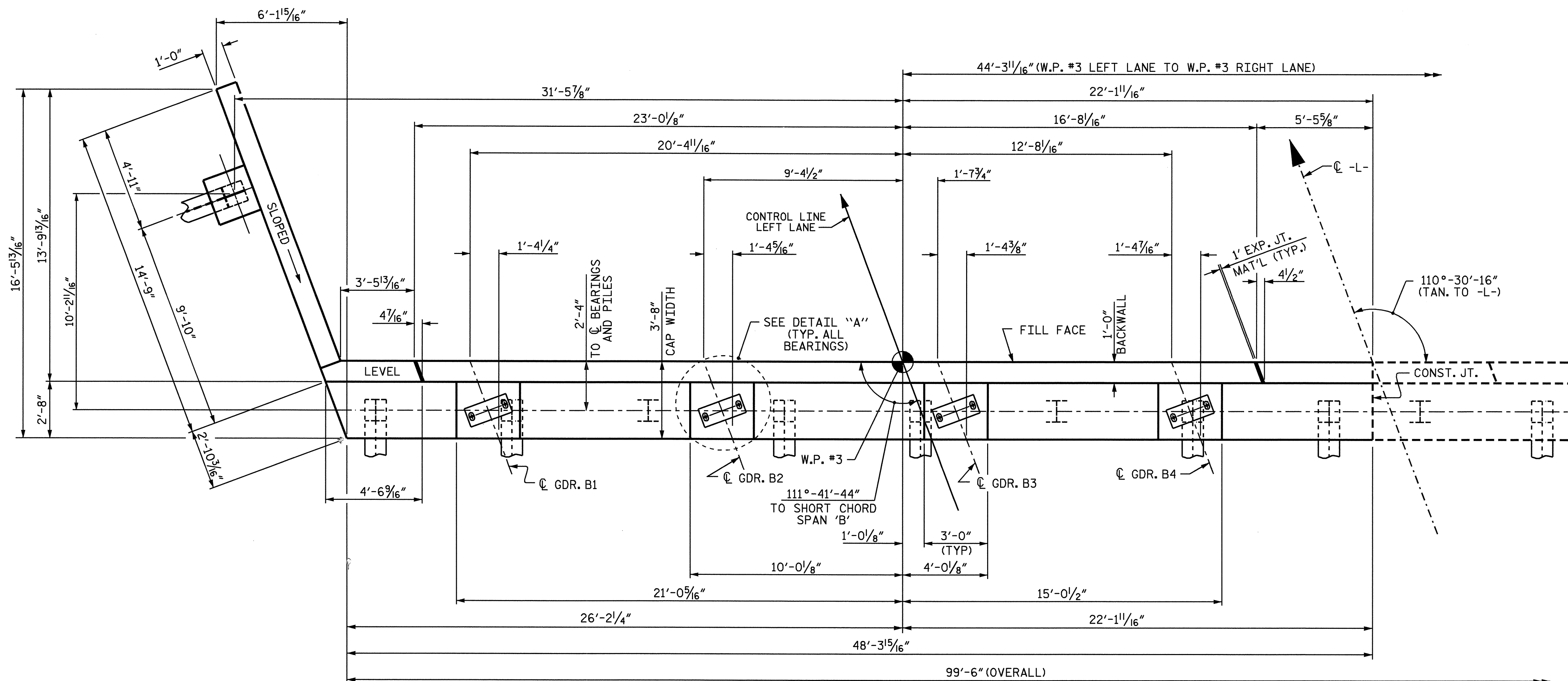

PLAN

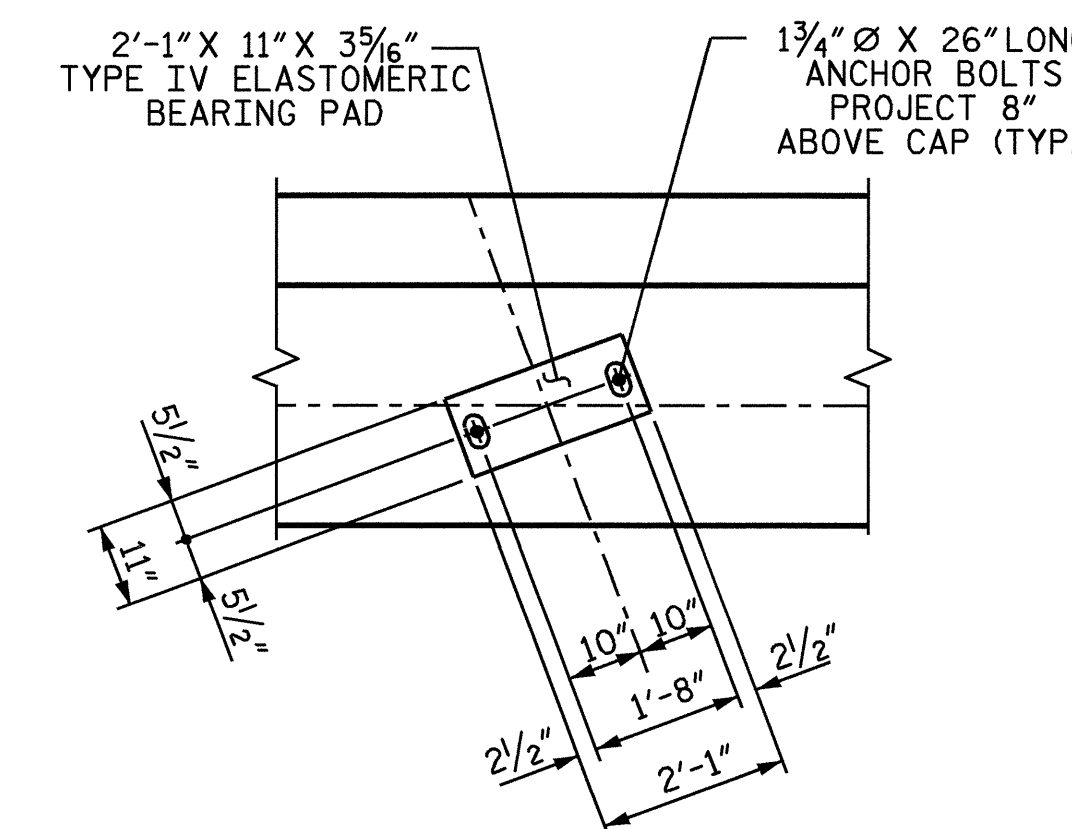

DETAIL "A"

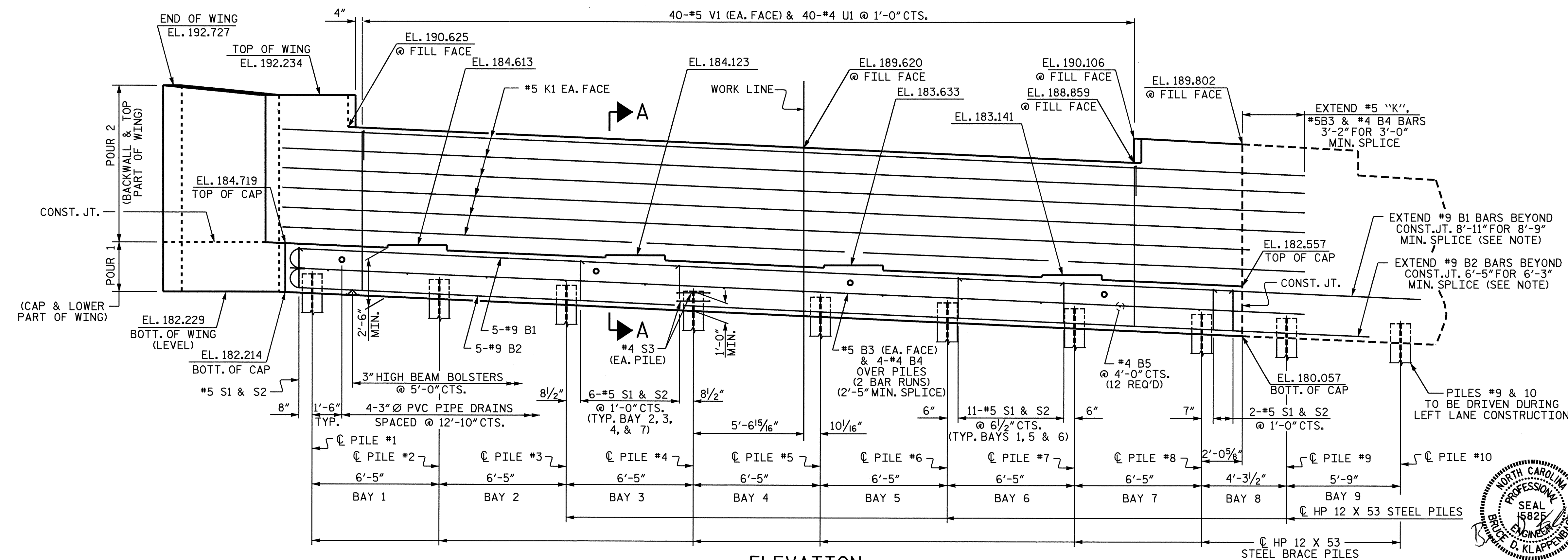

ELEVATION

TOP OF PILE ELEV.	
PILE No.	TOP OF PILE ELEV.
#1	183.156
#2	182.869
#3	182.582
#4	182.295
#5	182.007
#6	181.720
#7	181.433
#8	181.146
#9	180.958
#10	180.701

PROJECT NO. U-0620  
 CUMBERLAND COUNTY  
 STATION: 161+95.29 -L-

SHEET 1 OF 3

STATE OF NORTH CAROLINA  
 DEPARTMENT OF TRANSPORTATION  
 RALEIGH

SUBSTRUCTURE  
 END BENT 2  
 (LEFT LANE)

REVISIONS				SHEET NO.	
NO.	BY:	DATE:	NO.	BY:	DATE:
1			3		
2			4		

TOTAL SHEETS  
129

DRAWN BY: G.M.Patterson DATE: 11-05-03  
 CHECKED BY: D.A. GLADDEN DATE: 01-29-04

03-AUG-2004 11:36  
 W:\squad\U0620\Str2and3\mpatterson\Microstation\U0620.ed.e2.02.dgn  
 mpatterson

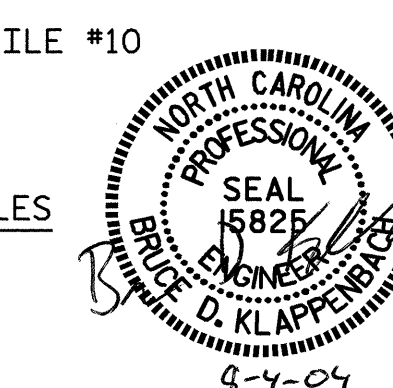

STR #2 NC006