



10/26/08

REVISIONS

|  |                       |           |
|--|-----------------------|-----------|
| <br><br>CONST. REV. | PROJECT REFERENCE NO. | SHEET NO. |
|  | R-2610B               | 2-H       |
| <br>R / W REV.  | R / W SHEET NO.       |           |
|  | 16-23-04              |           |

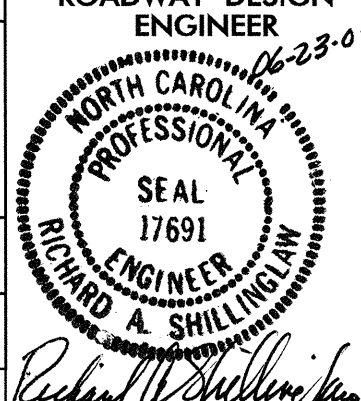
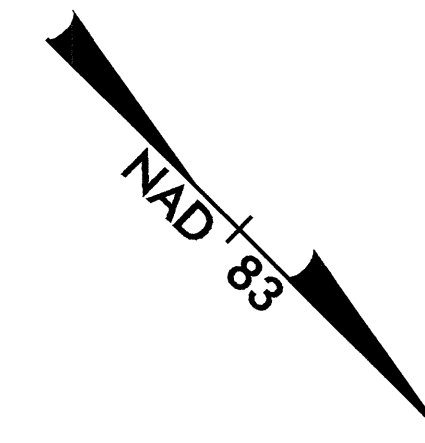

-L-  
 PI Sta. 87+10.370  
 $\Delta = 3^{\circ} 06' 53.4''$  (RT)  
 L = 190.456  
 T = 95.252  
 R = 3,503.352  
 SE = 02  
 RUNOFF = 18

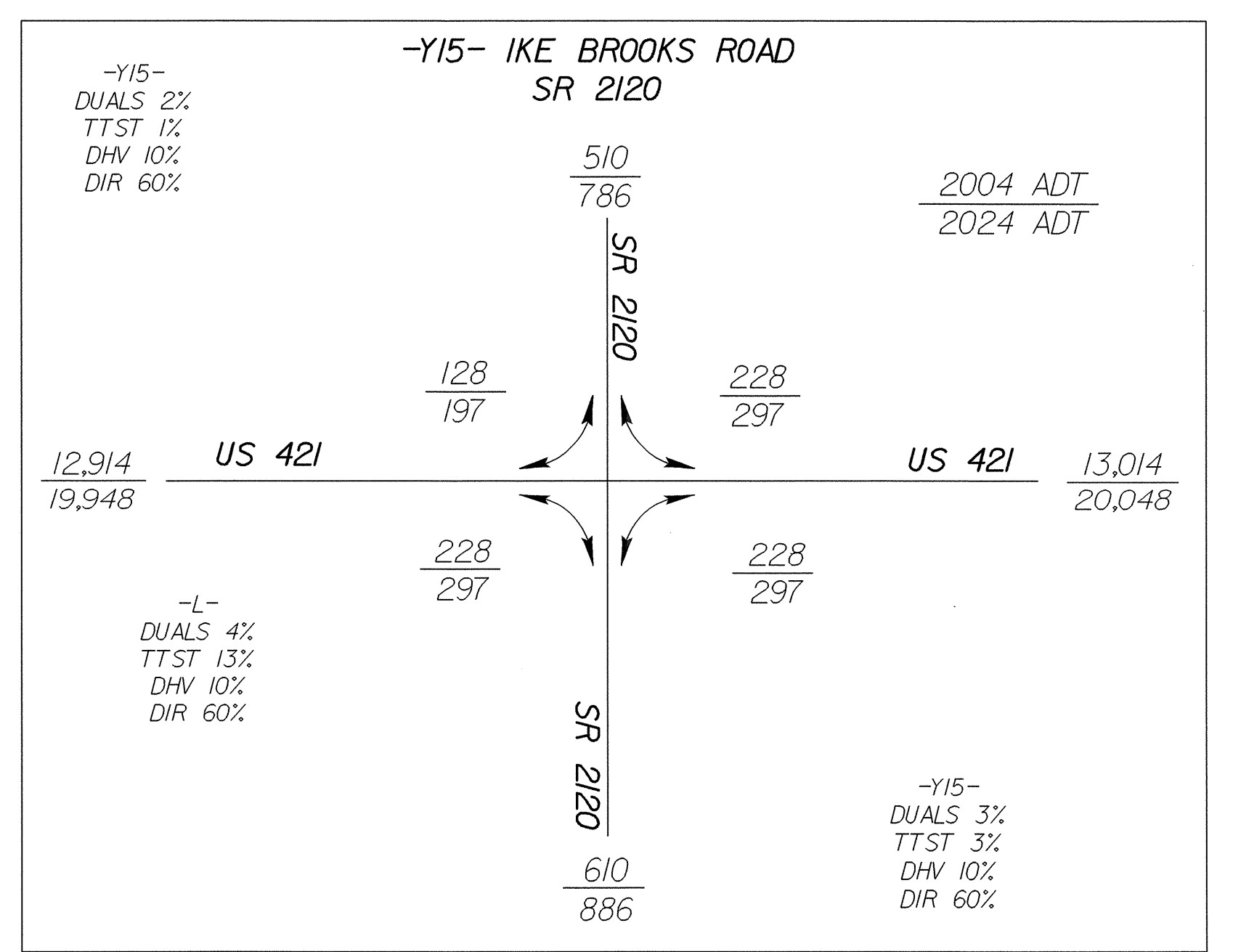
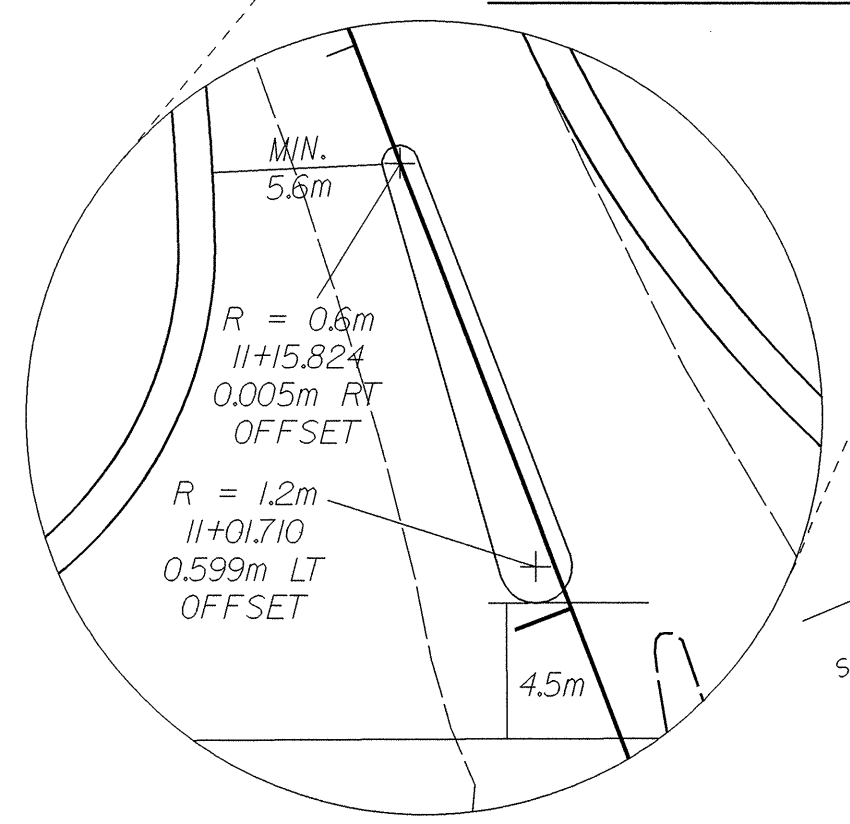
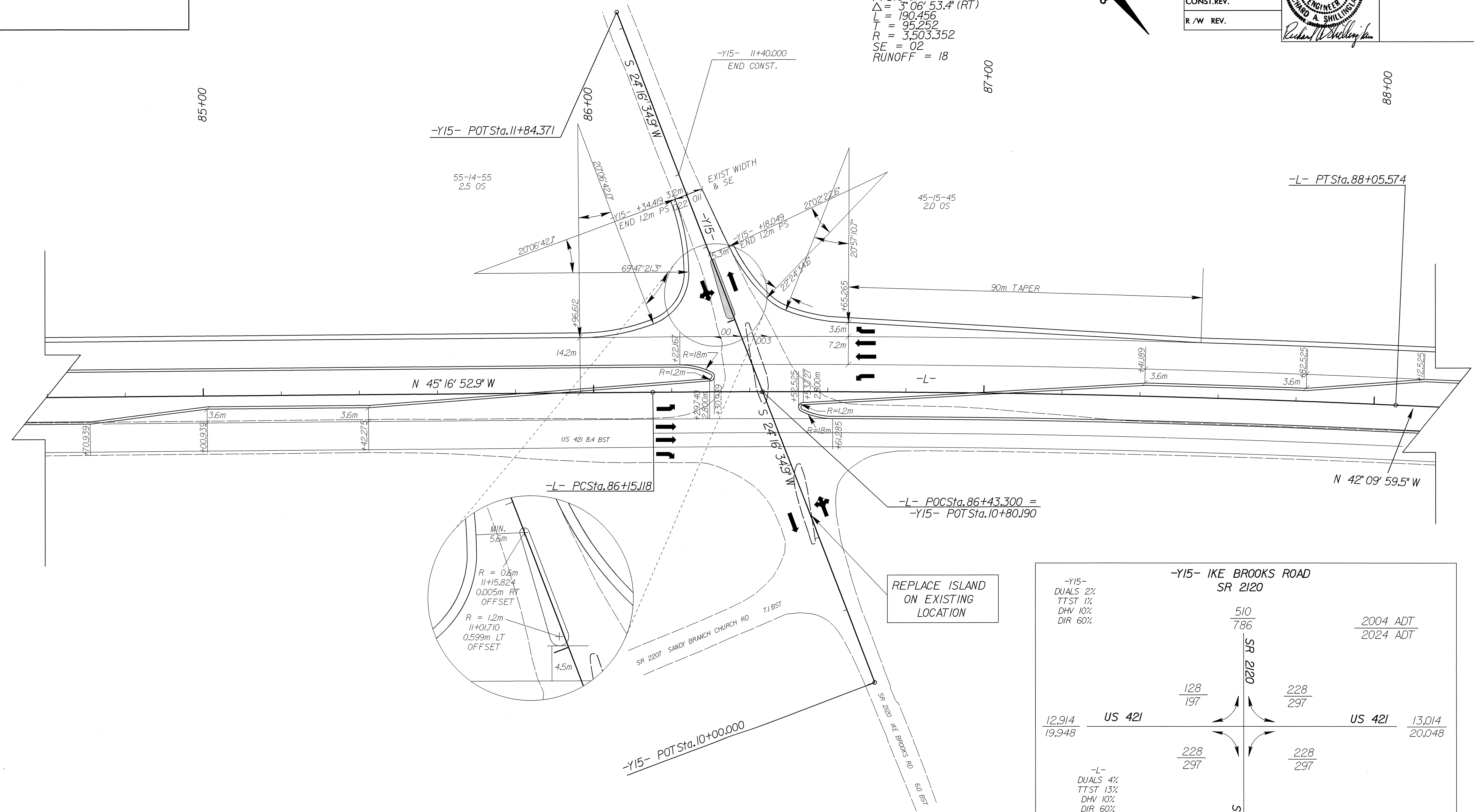

03-JUN-2004 13:46 R:\SHILLING\115\std.pdw