

NOTES

FOR ELASTOMERIC BEARINGS, SEE SPECIAL PROVISIONS.

AT ALL FIXED POINTS OF SUPPORT, NUTS FOR ANCHOR BOLTS ARE TO BE TIGHTENED FINGER TIGHT AND THEN BACKED OFF 1/2 TURN. THE THREAD OF THE NUT AND BOLT SHALL THEN BE BURRED WITH A SHARP POINTED TOOL.

THE 51mm Ø PIPE SLEEVE SHALL BE CUT FROM SCHEDULE 40 PVC PLASTIC PIPE. THE PVC PLASTIC PIPE SHALL MEET THE REQUIREMENTS OF ASTM D1785.

STEEL SOLE PLATES, ANCHOR BOLTS, NUTS, AND WASHERS SHALL BE GALVANIZED IN ACCORDANCE WITH THE STANDARD SPECIFICATIONS.

PRIOR TO WELDING, GRIND THE GALVANIZED SURFACE OF THE PORTION OF THE EMBEDDED PLATE AND SOLE PLATE THAT ARE TO BE WELDED. AFTER WELDING, DAMAGED GALVANIZED SURFACES SHALL BE REPAIRED IN ACCORDANCE WITH THE STANDARD SPECIFICATIONS.

WHEN WELDING THE SOLE PLATE TO THE EMBEDDED PLATE IN THE GIRDER, USE TEMPERATURE INDICATING WAX PENS, OR OTHER SUITABLE MEANS, TO ENSURE THAT THE TEMPERATURE OF THE SOLE PLATE DOES NOT EXCEED 149°C. TEMPERATURES ABOVE THIS MAY DAMAGE THE ELASTOMER.

SOLE PLATE "P", BOLTS, NUTS, WASHERS, AND PIPE SLEEVE SHALL BE INCLUDED IN THE PAY ITEM FOR PRESTRESSED CONCRETE GIRDERS.

ANCHOR BOLTS SHALL MEET THE REQUIREMENTS OF ASTM A449. NUTS SHALL MEET THE REQUIREMENTS OF AASHTO M291M-12 OR AASHTO M292M-2H. WASHERS SHALL MEET THE REQUIREMENTS OF AASHTO M293M. SHOP DRAWINGS ARE NOT REQUIRED FOR ANCHOR BOLTS, NUTS AND WASHERS. SHOP INSPECTION IS REQUIRED.

ALL SURFACES OF BEARING PLATES SHALL BE SMOOTH AND STRAIGHT.

— LOAD RATINGS —

	MAX.D.L.+L.L.
1372mm PCG -TYPE V	801 kN
1372mm PCG -TYPE VI	936 kN

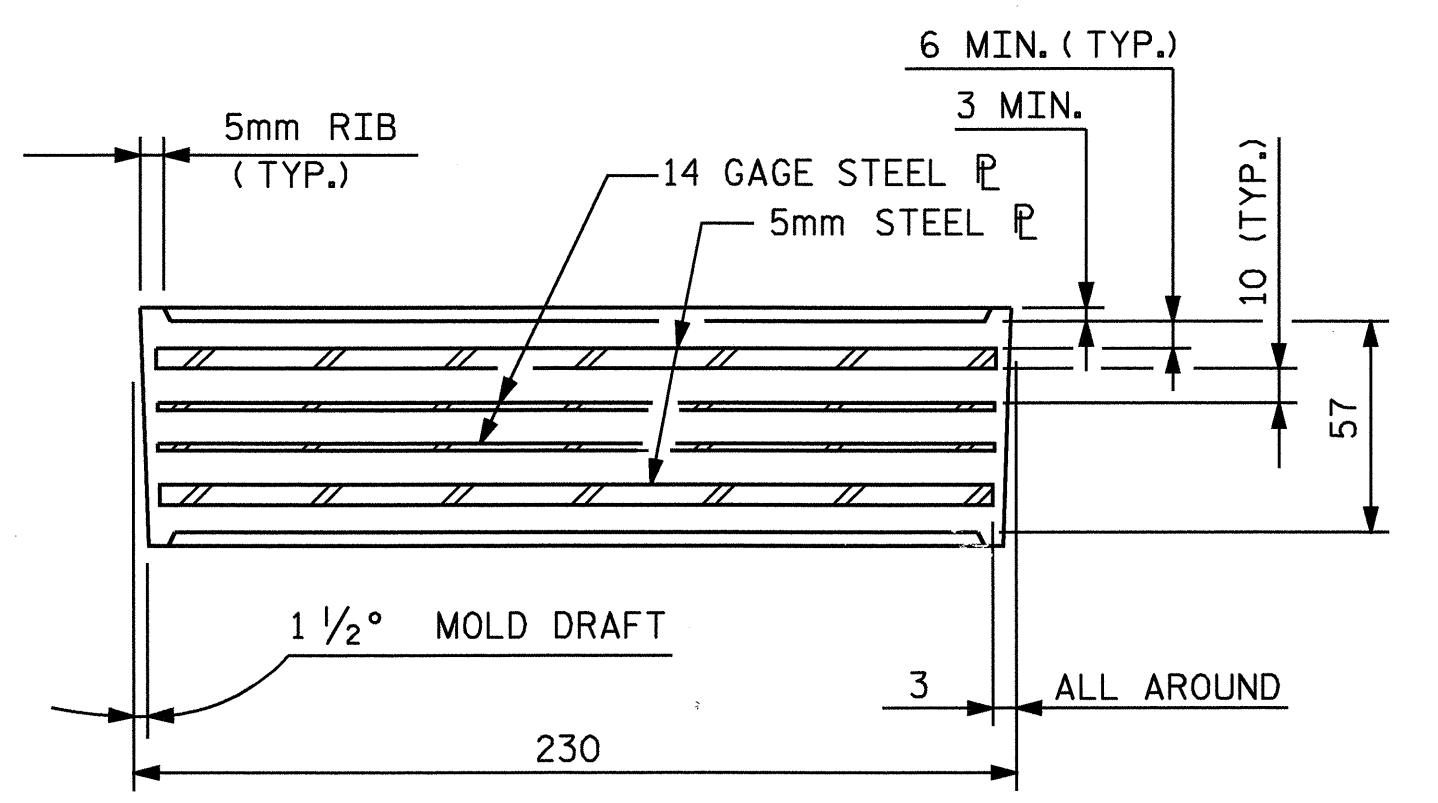
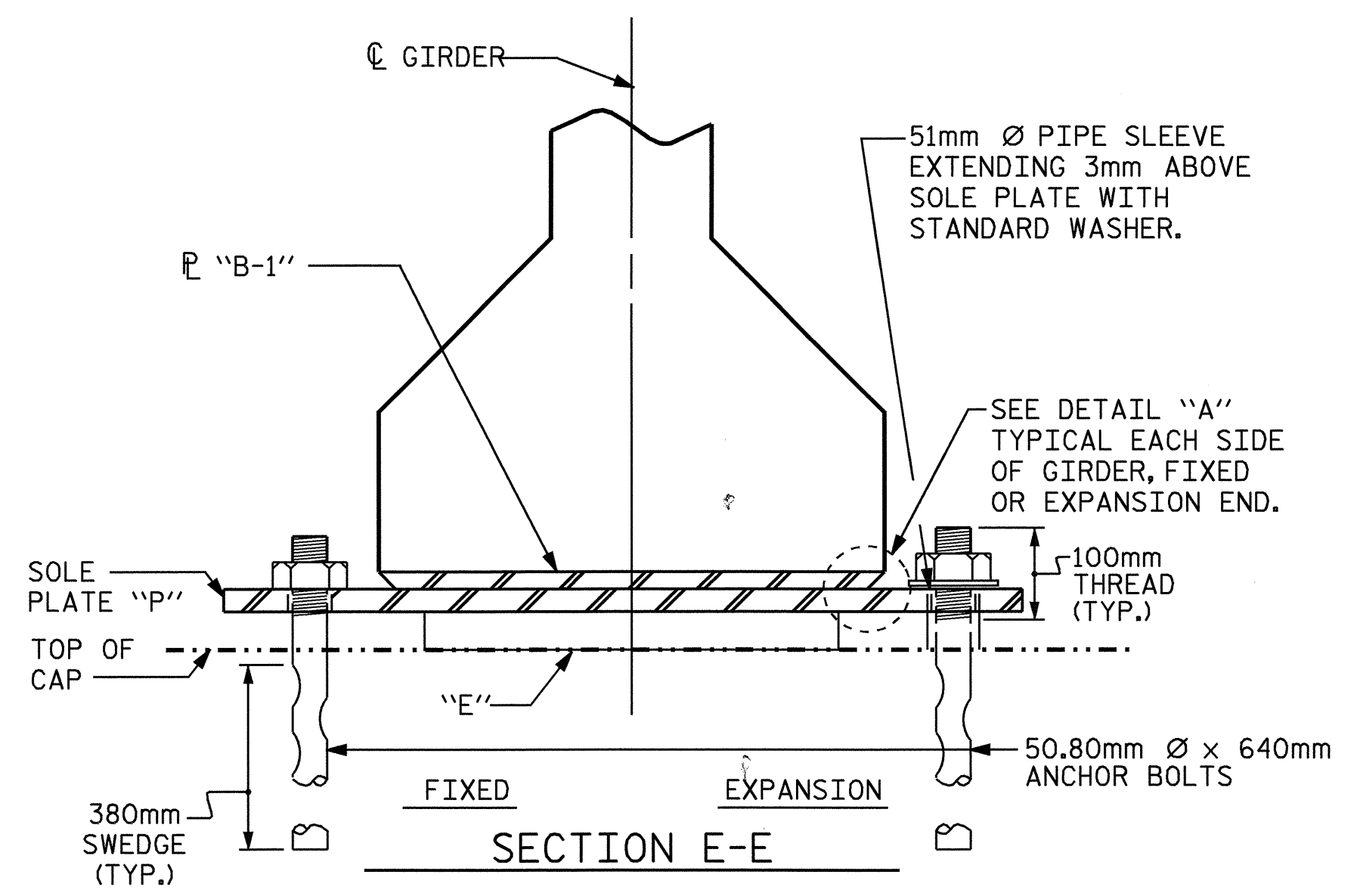

TYPICAL SECTION OF ELASTOMERIC BEARINGS

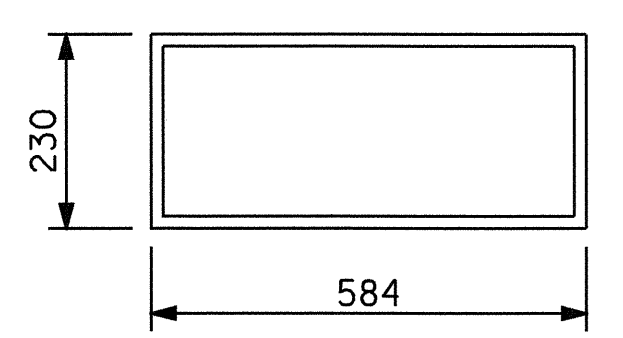

E1 (16 REQ'D)
PLAN VIEW OF ELASTOMERIC BEARING
TYPE V

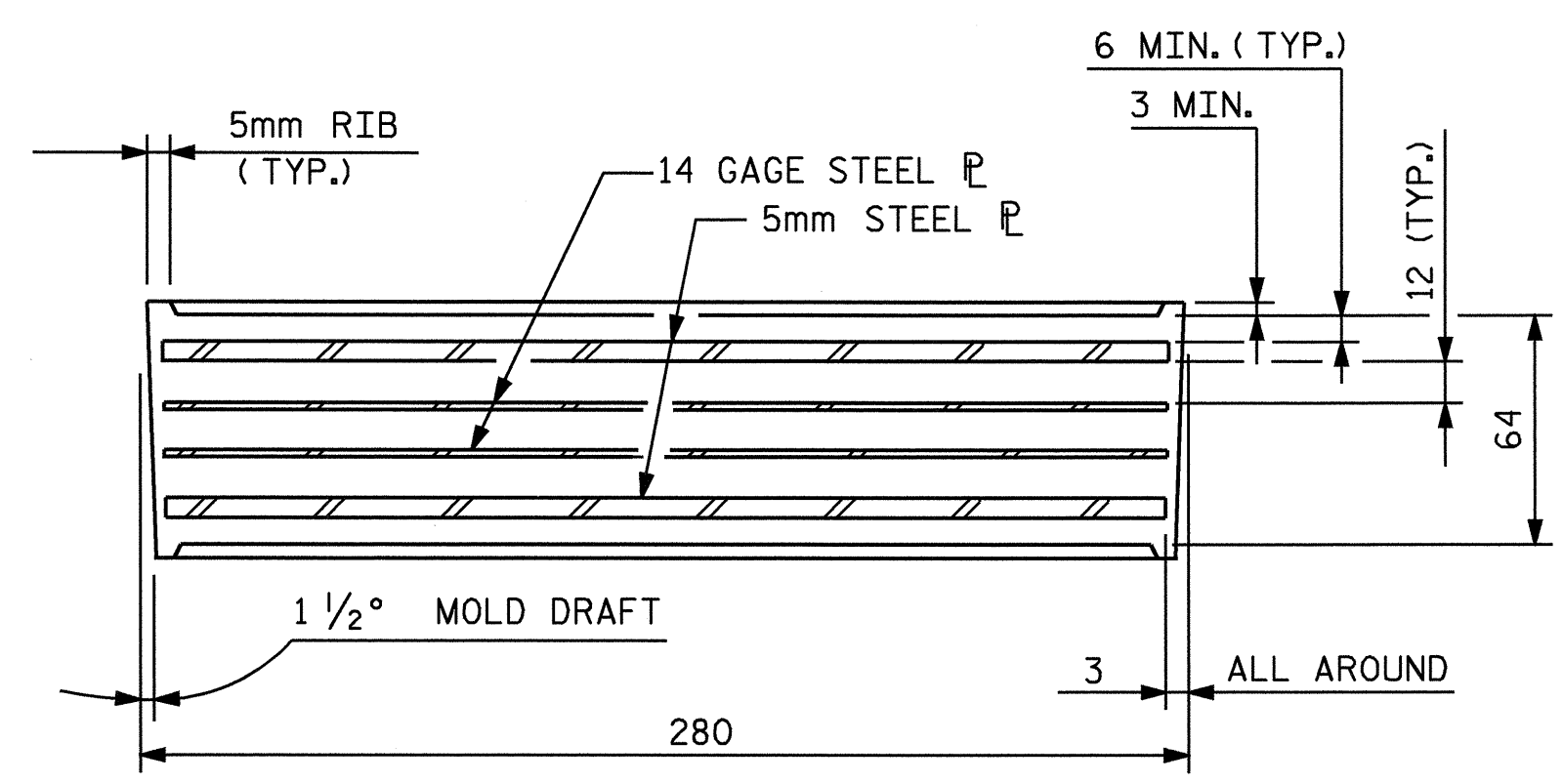

TYPICAL SECTION OF ELASTOMERIC BEARINGS

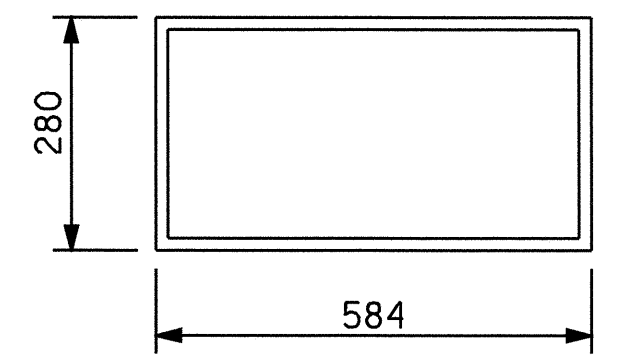

E2 (8 REQ'D)
PLAN VIEW OF ELASTOMERIC BEARING
TYPE VI

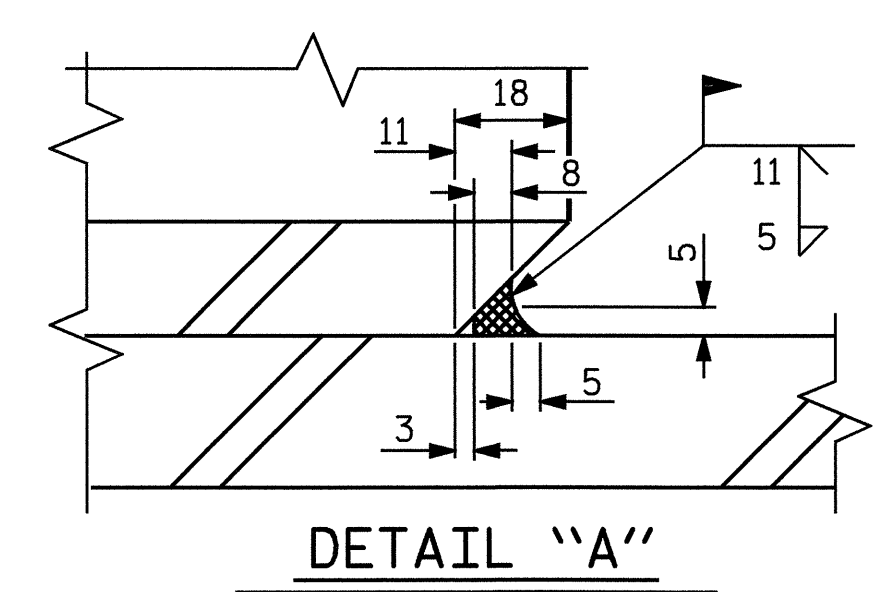

DETAIL "A"

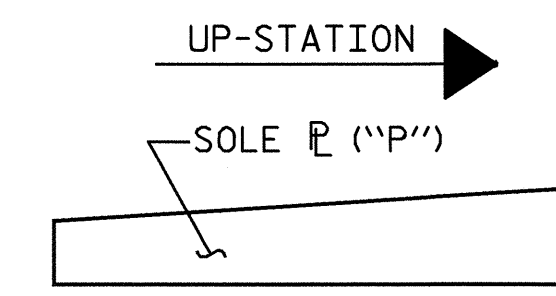

SOLE PLACEMENT DETAIL

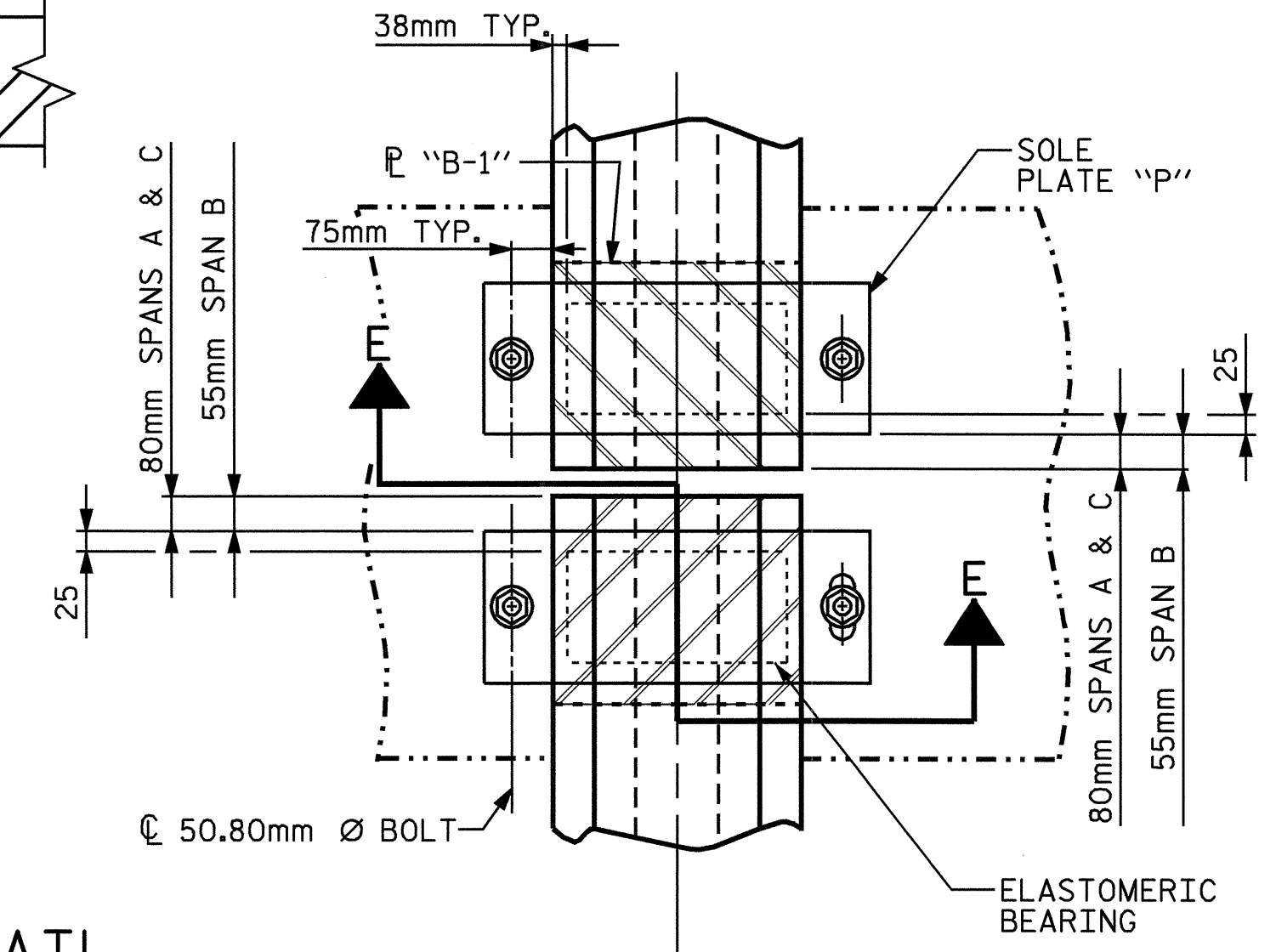

TYPICAL HALF-PLAN

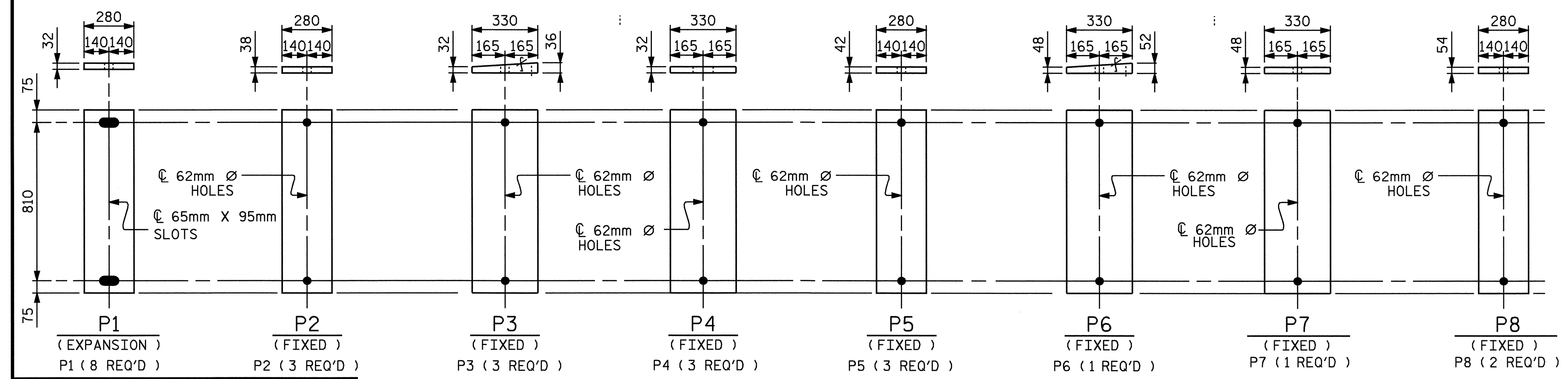

SOLE PLATE DETAILS ("P")

ASSEMBLED BY : H. T. BARBOUR DATE : 5-14-04
 CHECKED BY : D. A. DAVENPORT DATE : 5-04

DRAWN BY : WJH 8/89 REV. 8/16/99 RWW/LES
 CHECKED BY : CRK 8/89 REV. 10/17/00 RWW/LES
 REV. 7/10/01 RWW/LES

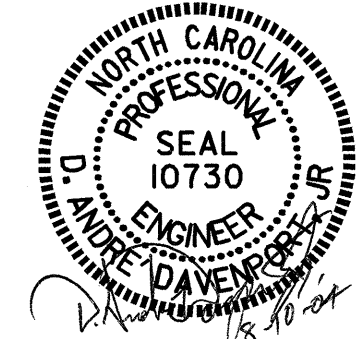

PROJECT NO. R-2610B
CHATHAM COUNTY
 STATION: 22+83.400-L-

STATE OF NORTH CAROLINA
 DEPARTMENT OF TRANSPORTATION
 RALEIGH

**ELASTOMERIC BEARING
 DETAILS**

PRESTRESSED CONCRETE GIRDER
 SUPERSTRUCTURE

REVISIONS						SHEET NO.
NO.	BY:	DATE:	NO.	BY:	DATE:	S-13
1			3			TOTAL SHEETS
2			4			60