

HALF SECTION @ INTERMEDIATE DIAPHRAGMS

HALF SECTION @ 1'-0" Ø VOIDS

**TYPICAL SECTION**

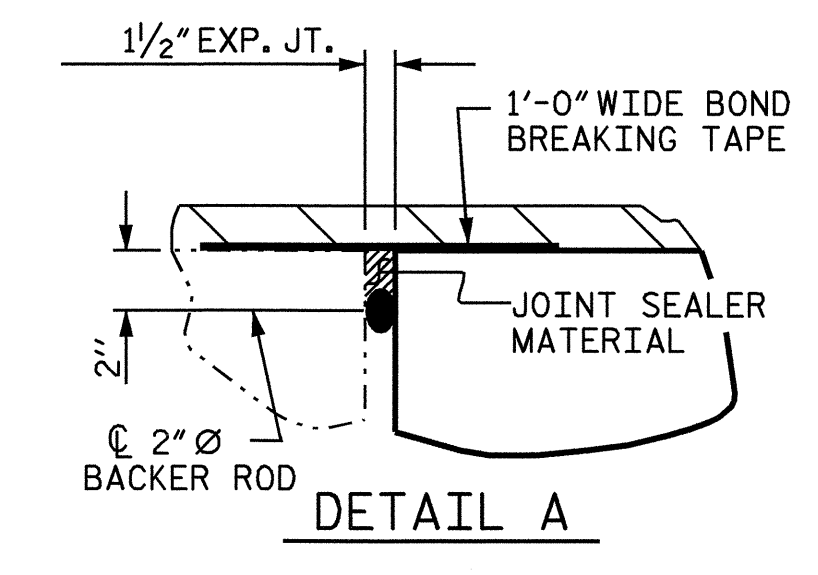

DETAIL A

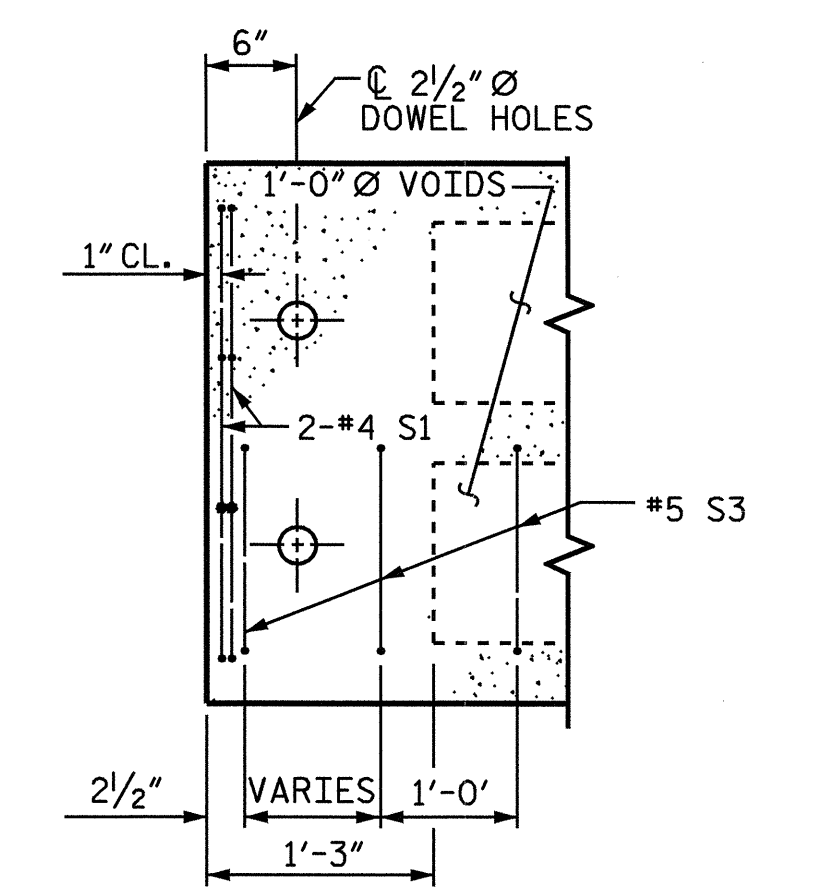

PART PLAN-EXTERIOR SECTION

NOTE: EXTERIOR SECTION SHOWN-INTERIOR SECTION SIMILAR EXCEPT OMIT S3 BARS. SEE PLAN OF SPAN

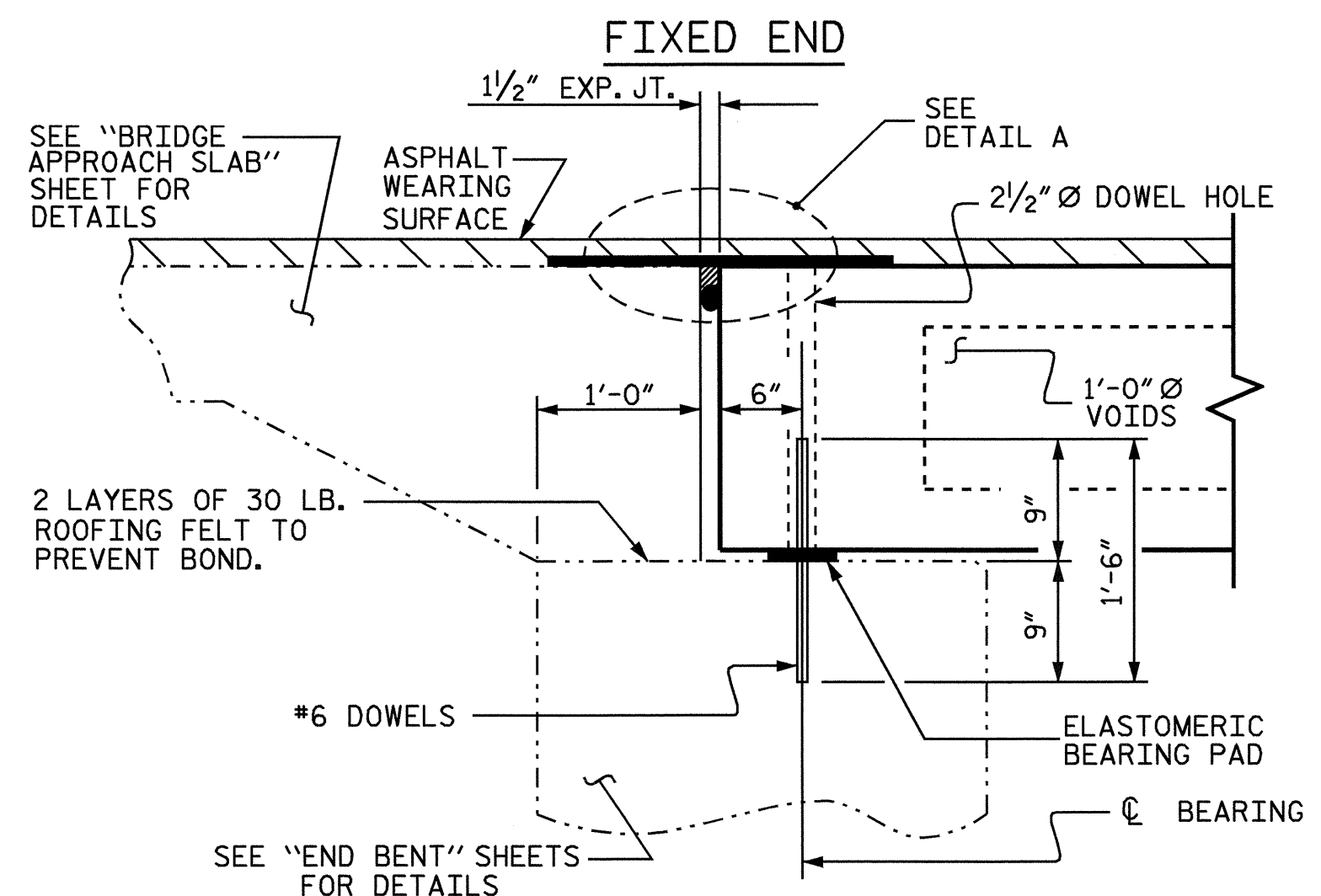

SECTION AT END BENT

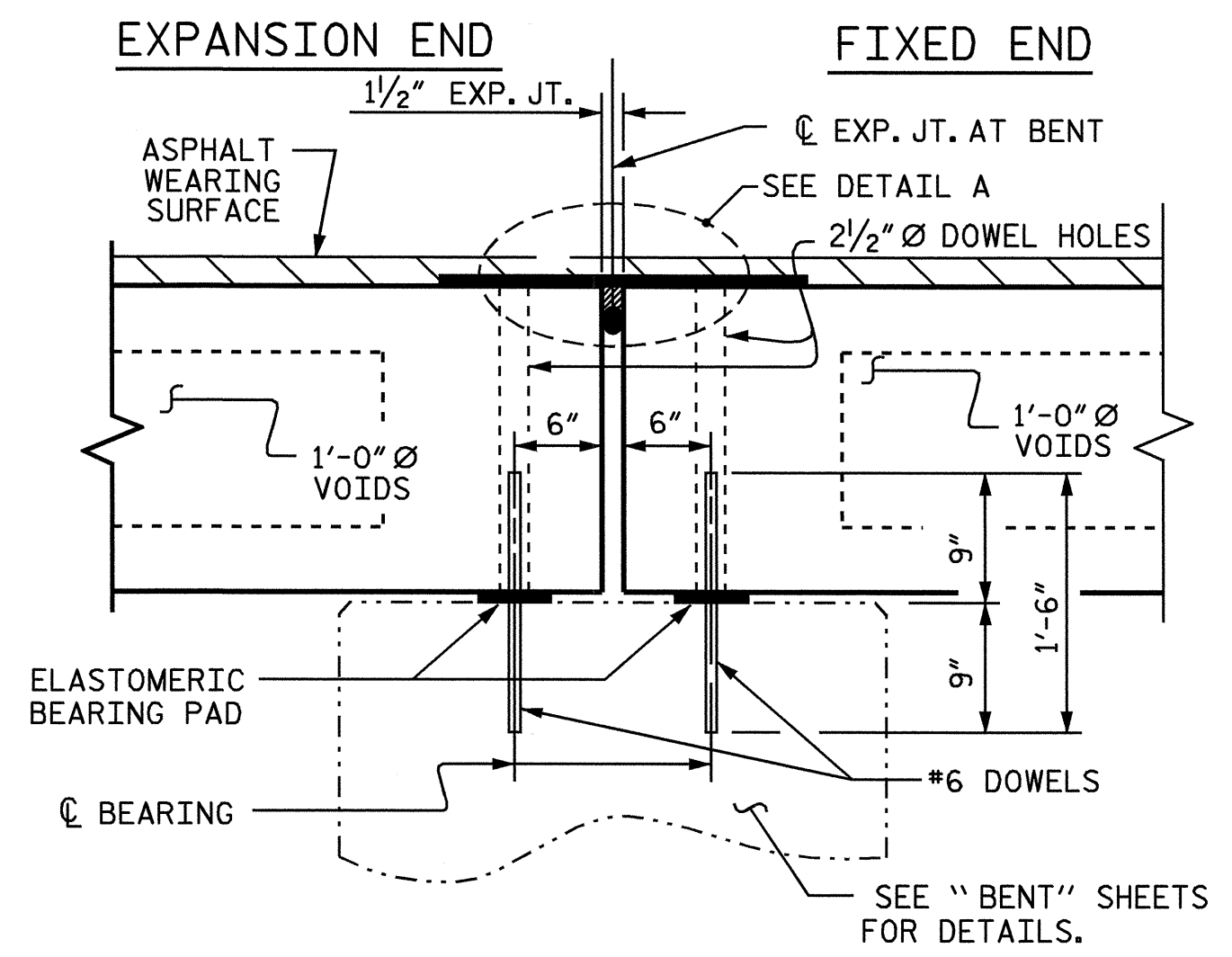

SECTION AT BENT

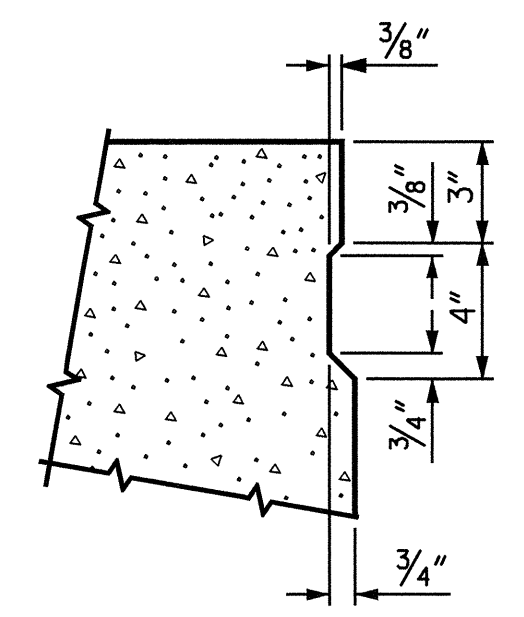

SHEAR KEY DETAIL  
NOTE: OMIT SHEAR KEY ON OUTSIDE FACE OF EXTERIOR CORED SLABS.

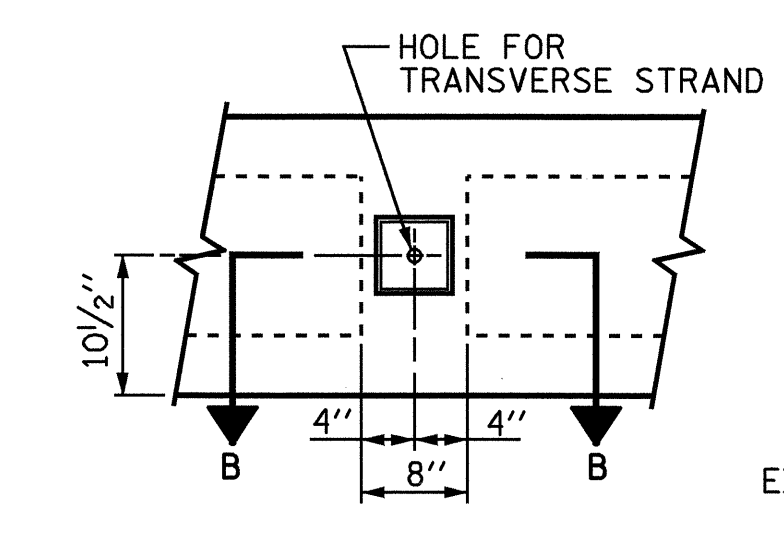

ELEVATION VIEW

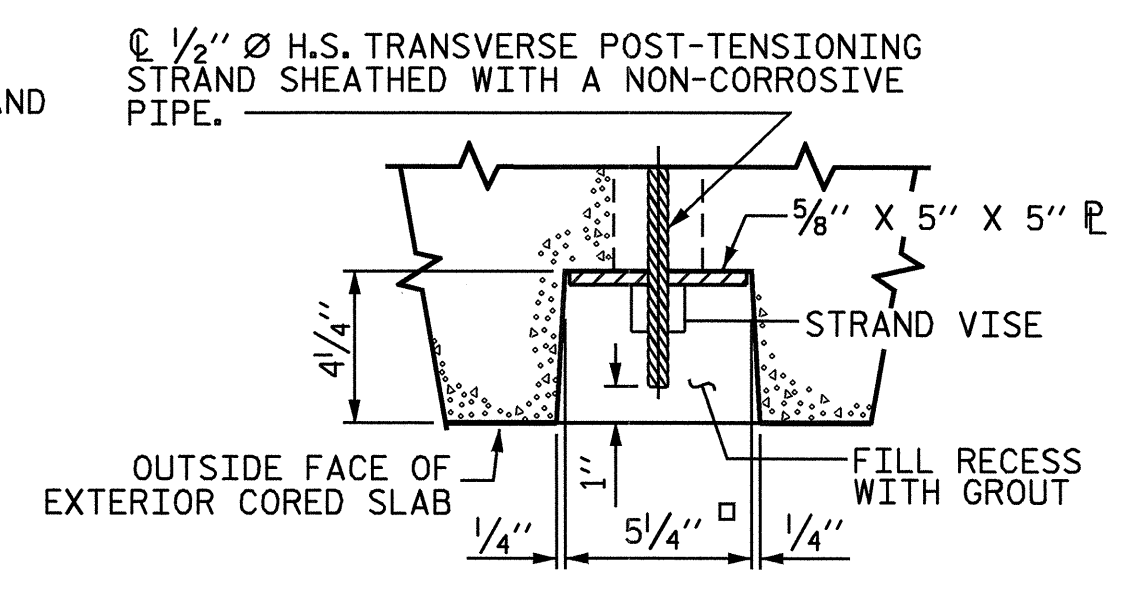

SECTION B-B

**GROUTED RECESS AT END OF POST-TENSIONED STRAND CORED SLABS**

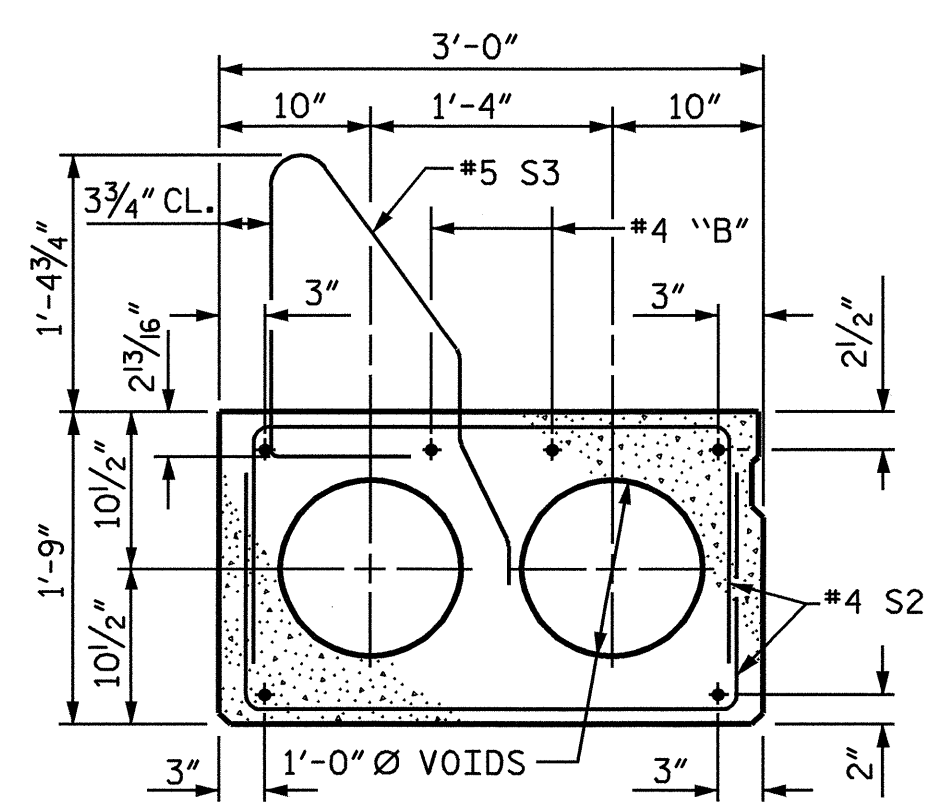

EXTERIOR SLAB SECTION  
(FOR PRESTRESSED STRAND LAYOUT, SEE INTERIOR SLAB SECTION.)

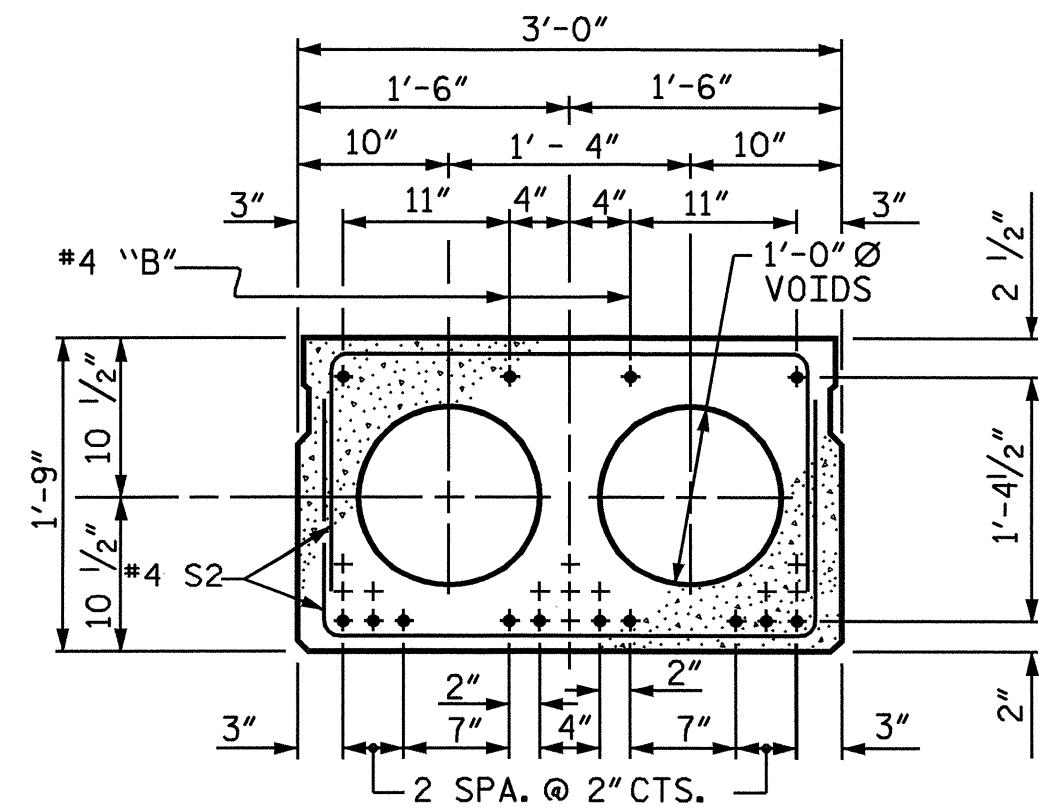

1/2" Ø LOW RELAXATION STRAND LAYOUT  
SPAN A OR E INTERIOR

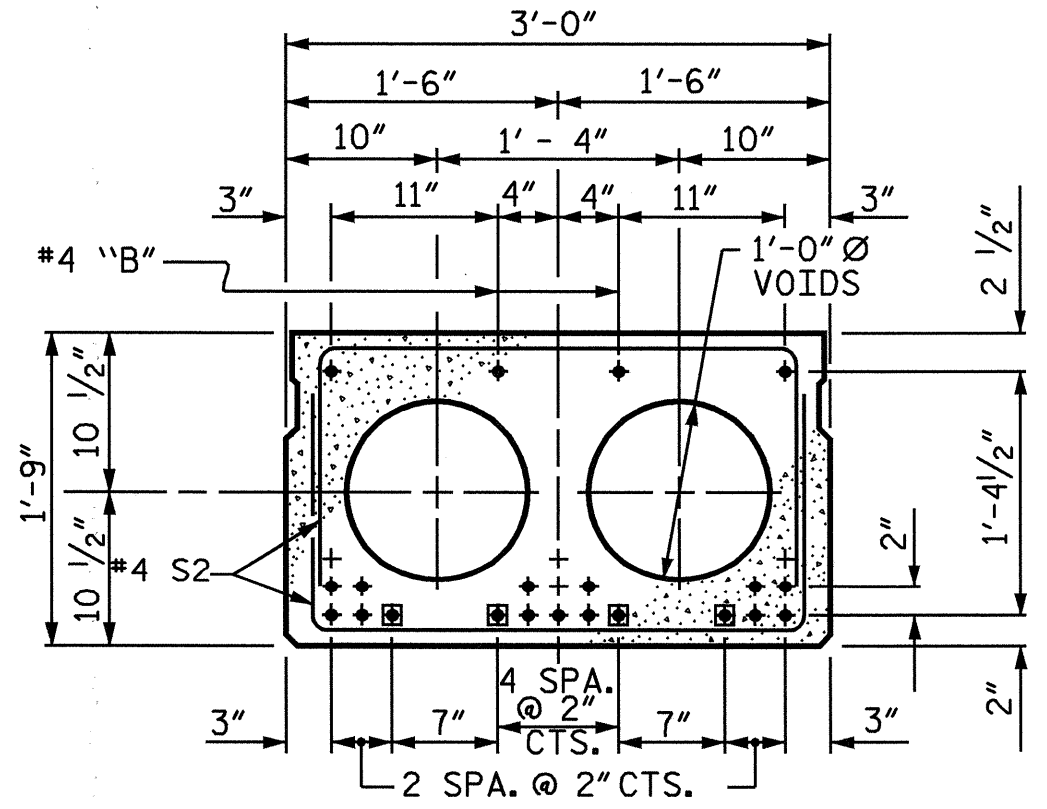

1/2" Ø LOW RELAXATION STRAND LAYOUT  
SPAN B THROUGH D INTERIOR

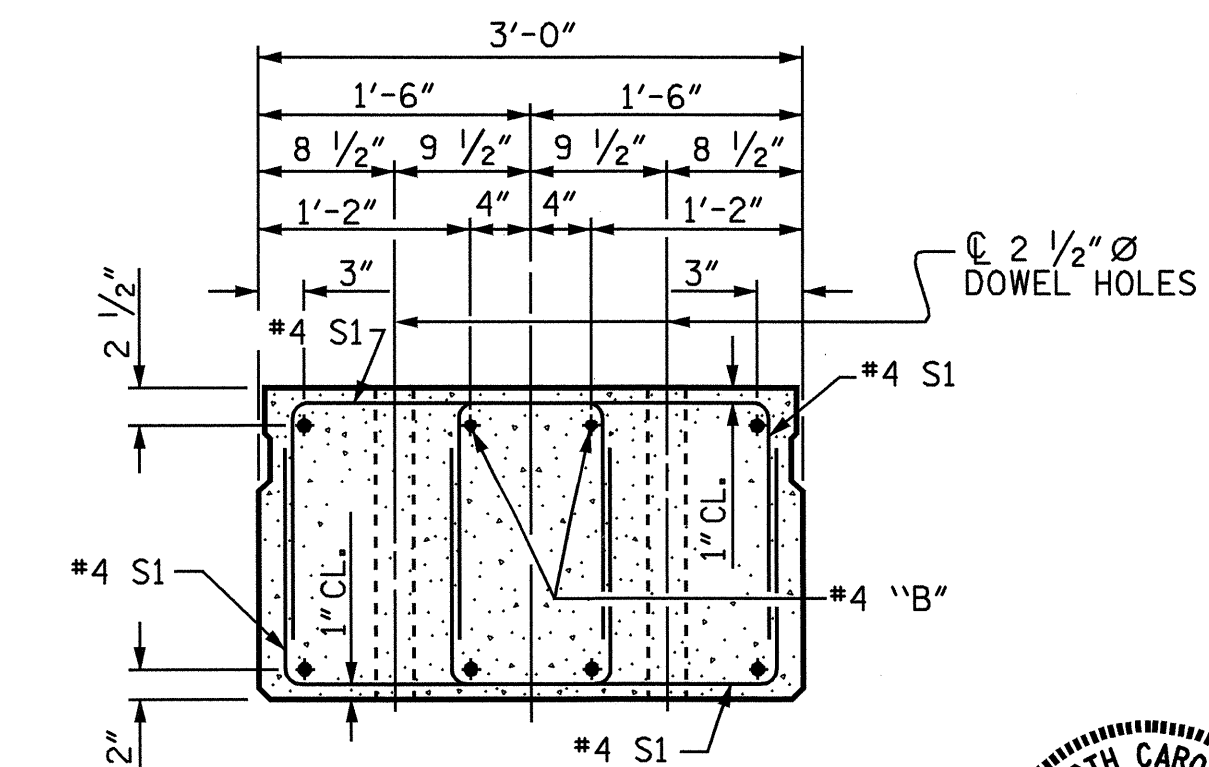

END ELEVATION

SHOWING PLACEMENT OF DOUBLE STIRRUPS AND LOCATION OF DOWEL HOLES. (STRAND LAYOUT NOT SHOWN.) INTERIOR SLAB SECTION SHOWN-EXTERIOR SLAB SECTION SIMILAR EXCEPT SHEAR KEY LOCATION.

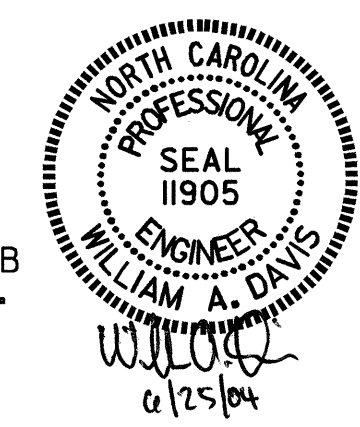

PROJECT NO. B-3629  
CASWELL COUNTY  
STATION: 26+65.00 -L-

SHEET 1 OF 5

STATE OF NORTH CAROLINA  
DEPARTMENT OF TRANSPORTATION  
RALEIGH

STANDARD  
3'-0" X 1'-9"  
PRESTRESSED CONCRETE  
CORED SLAB UNIT

REVISIONS						SHEET NO.
NO.	BY:	DATE:	NO.	BY:	DATE:	S-4
1			3			TOTAL SHEETS
2			4			26

ASSEMBLED BY: J.D. HAWK	DATE: 1/1/04
CHECKED BY: J.G. KHARVA	DATE: 1/15/04
DRAWN BY: WJH 4/89	REV. 8/16/99 RWW/LES
CHECKED BY: FCJ 5/89	REV. 10/17/00 RWW/LES
	REV. 7/10/01 RWW/LES