

SECTION A-A @ -L- 15+00

PROJ. REFERENCE NO.	SHEET NO.
B-3623	TCP-6

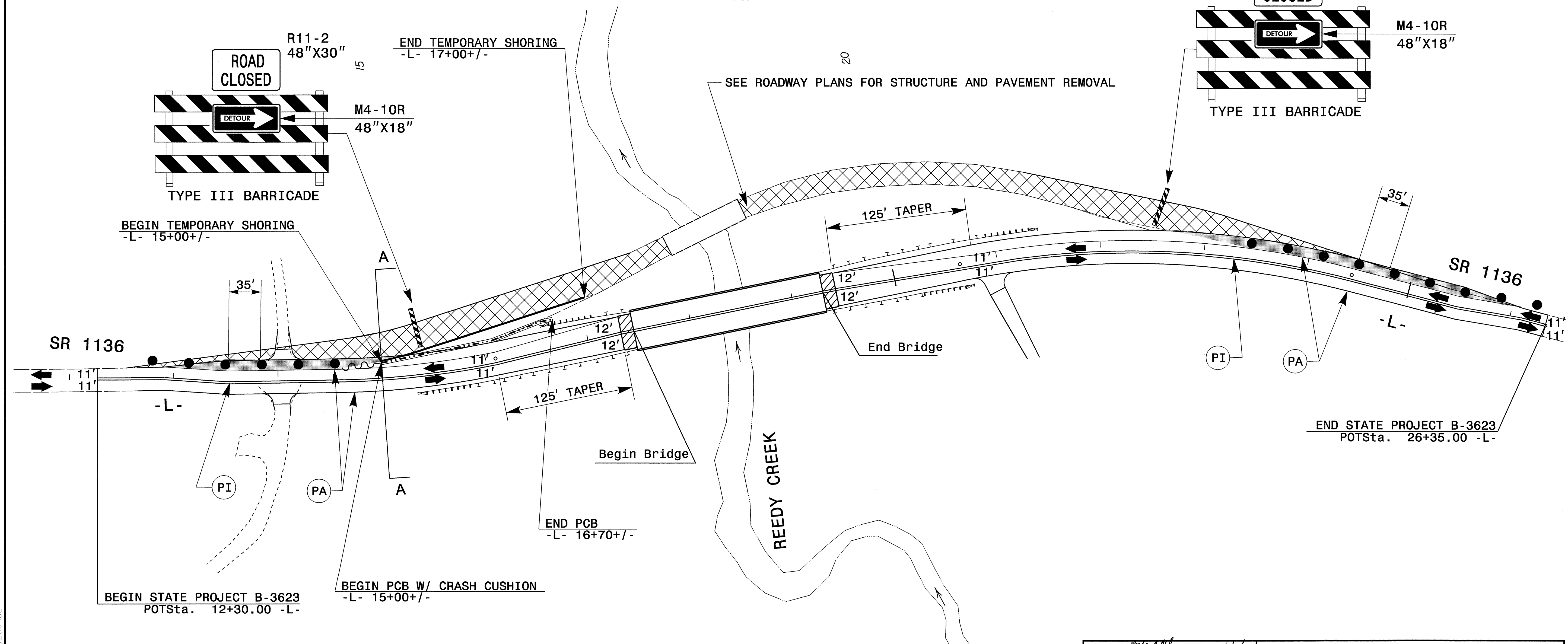
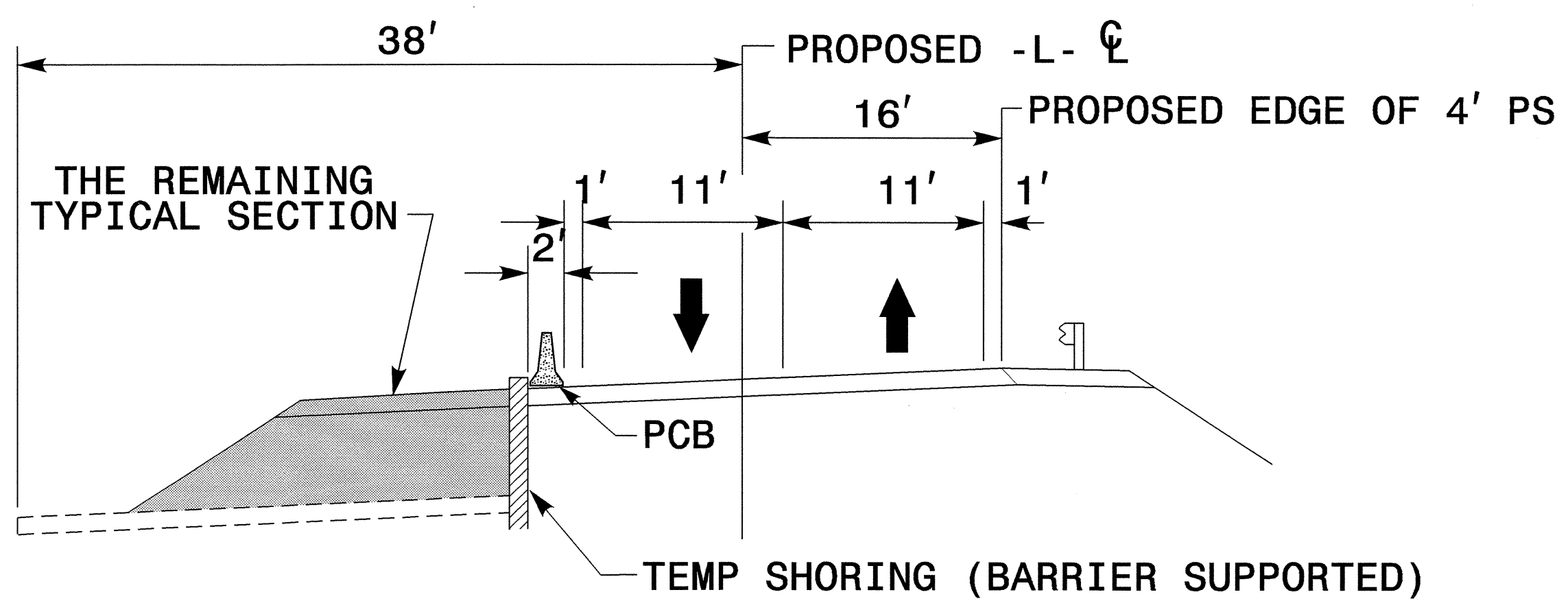

02-DEC-2003 10:50  
 G:\TCP\B3623-Fc-base01.dgn  
 DER\charleson AT TETC206432

TEMPORARY PAVEMENT TO BE REMOVED

APPROVED:	DATE: 12/2/03	<b>PHASE III</b>							
	SCALE: NONE								
	DATE: 04/03								
	DWG. BY: DER								
	DESIGN BY: DER								
REVIEWED BY: MJH		<table border="1"> <thead> <tr> <th colspan="2">REVISIONS</th> </tr> </thead> <tbody> <tr> <td> </td> <td> </td> </tr> <tr> <td> </td> <td> </td> </tr> </tbody> </table>		REVISIONS					
REVISIONS									
<table border="1"> <tr> <td>CADD FILE</td> <td>B3623_TC_BASE01.DGN</td> </tr> </table>		CADD FILE	B3623_TC_BASE01.DGN						
CADD FILE	B3623_TC_BASE01.DGN								