

**GRADE DATA**

(-)1.0000% (+)0.3000%  
 PI = 24+50.00 -L-  
 PI EL. = 2,791.26'  
 VC = 200'

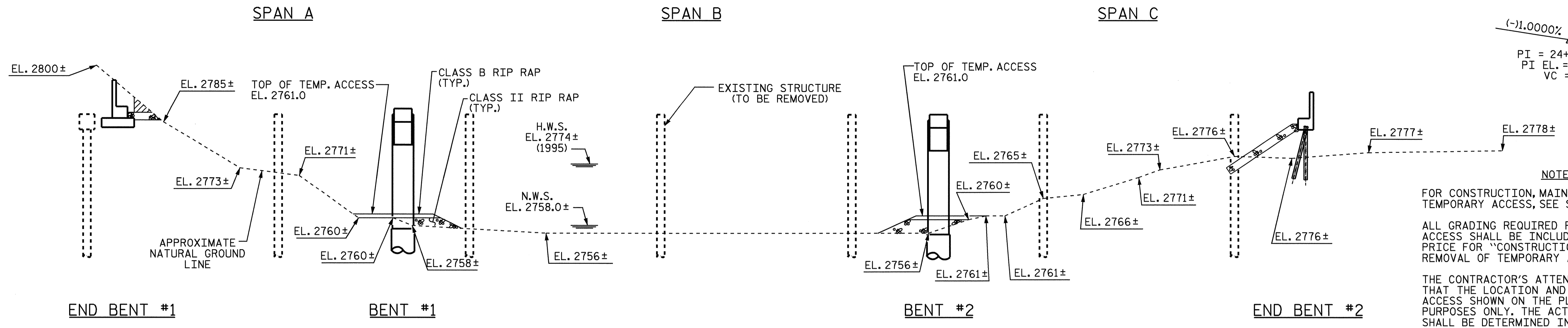

**NOTES**

FOR CONSTRUCTION, MAINTENANCE AND REMOVAL OF TEMPORARY ACCESS, SEE SPECIAL PROVISIONS.

ALL GRADING REQUIRED FOR ACCESS TO THE TEMPORARY ACCESS SHALL BE INCLUDED IN THE LUMP SUM BID PRICE FOR "CONSTRUCTION, MAINTENANCE, AND REMOVAL OF TEMPORARY ACCESS".

THE CONTRACTOR'S ATTENTION IS CALLED TO THE FACT THAT THE LOCATION AND PROFILE OF THE TEMPORARY ACCESS SHOWN ON THE PLANS IS FOR ESTIMATING PURPOSES ONLY. THE ACTUAL LOCATION AND PROFILE SHALL BE DETERMINED IN THE FIELD WITH THE APPROVAL OF THE ENGINEER.

FOR CLASS II RIP RAP AND CLASS B RIP RAP, SEE SPECIAL PROVISION, "CONSTRUCTION, MAINTENANCE, AND REMOVAL OF TEMPORARY ACCESS".

**SECTION ALONG C SURVEY -L-**  
 SECTION TAKEN AT RIGHT ANGLES TO BENTS AND END BENTS.

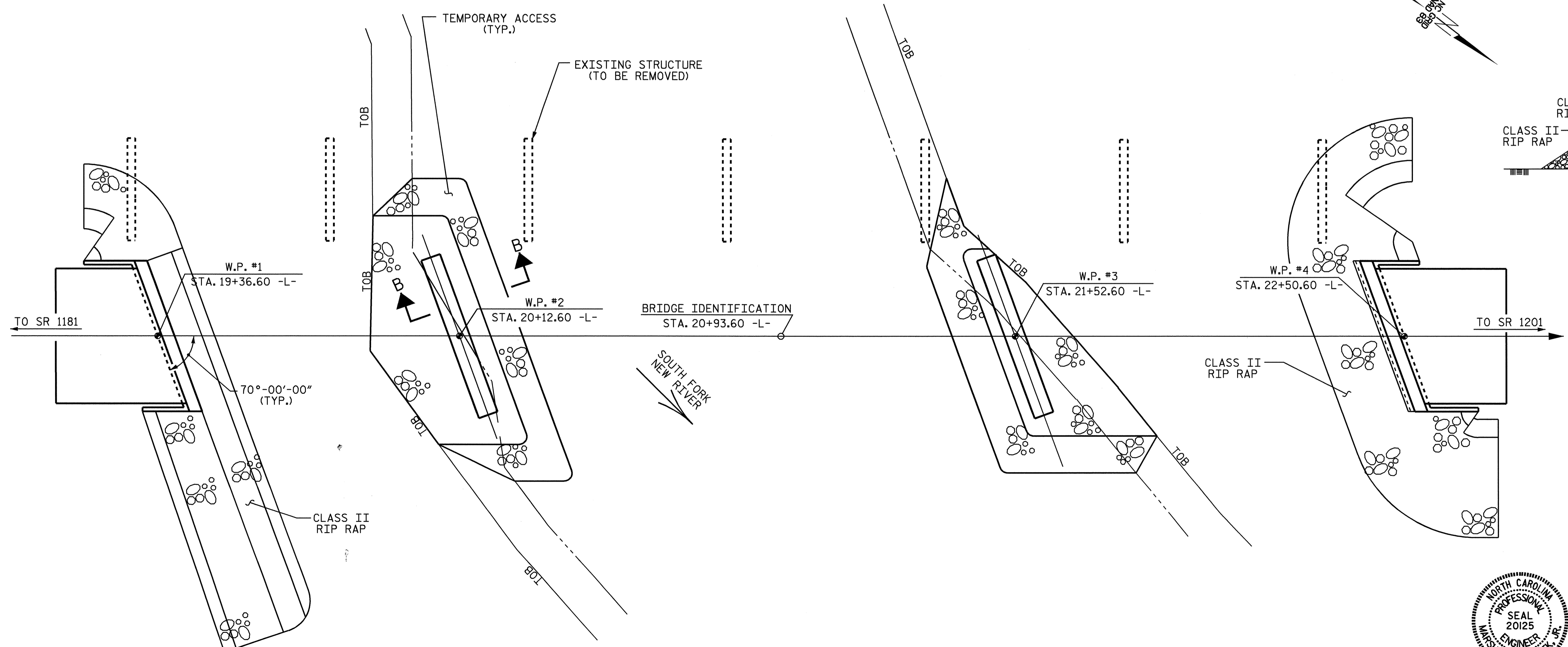

**PLAN**



PROJECT NO. B-4010  
ASHE COUNTY  
 STATION: 20+93.60 -L-  
 SHEET 1 OF 3

STATE OF NORTH CAROLINA  
 DEPARTMENT OF TRANSPORTATION  
 RALEIGH  
**TEMPORARY ACCESS  
 (PHASE I)**

REVISIONS						SHEET NO.
NO.	BY:	DATE:	NO.	BY:	DATE:	S-4
1			3			TOTAL SHEETS
2			4			37

DRAWN BY: CR LEWIS DATE: 06/04  
 CHECKED BY: MG CHEEK DATE: 07/04