

NOTES

STIRRUPS IN CAP MAY BE SHIFTED AS NECESSARY TO CLEAR DOWELS.

PIPE DRAINS MAY BE SHIFTED SLIGHTLY AS NECESSARY TO CLEAR REINFORCING STEEL AND DOWELS.

THE LATERAL GUIDE AT EACH END OF THE CAP IS NOT TO BE POURED UNTIL AFTER CORED SLAB UNITS ARE IN PLACE.

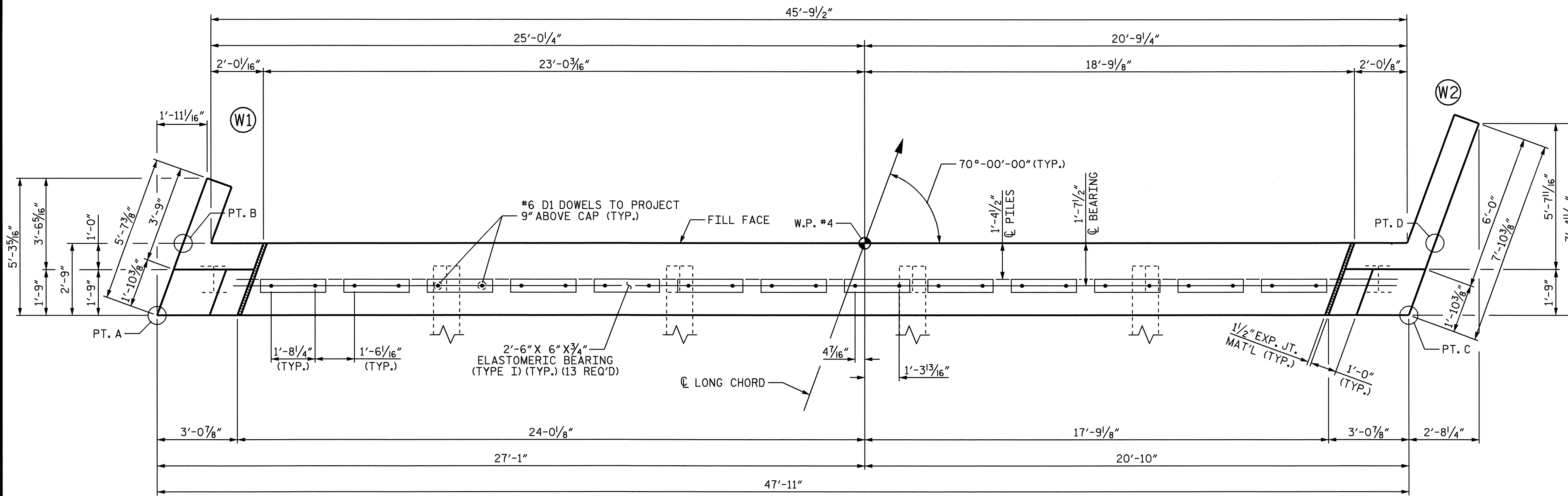

PLAN

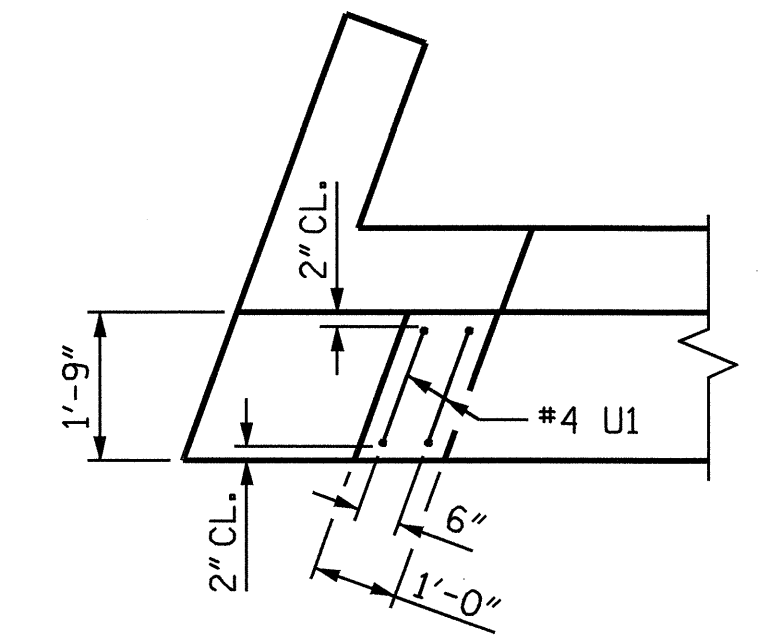

PLAN

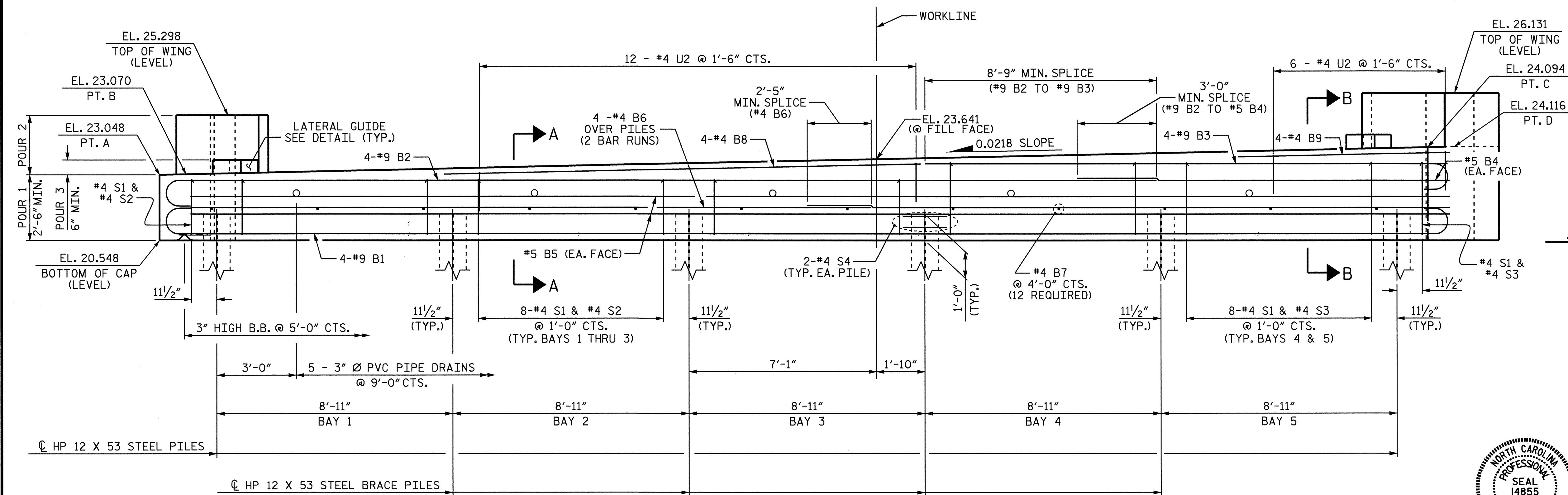

ELEVATION

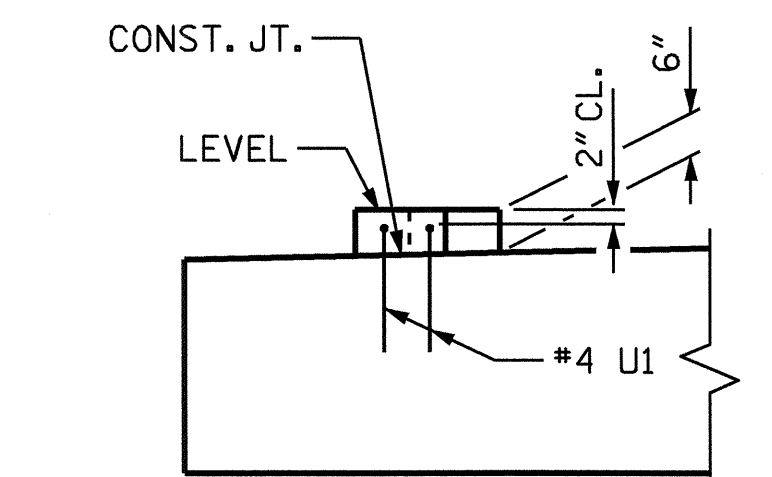

ELEVATION

LATERAL GUIDE DETAIL

PROJECT NO. B-3884

ONslow COUNTY

STATION: 14+89.75 -L-

SHEET 1 OF 3

STATE OF NORTH CAROLINA
DEPARTMENT OF TRANSPORTATION
RALEIGH

SUBSTRUCTURE
END BENT 2

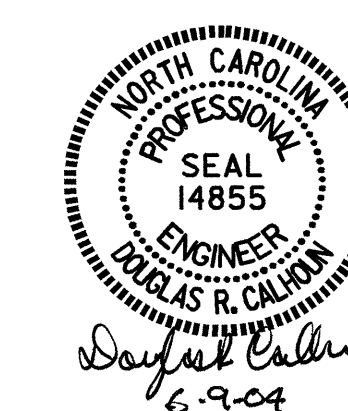

DRAWN BY: T.A. HARRIS DATE: 2/21/03
CHECKED BY: K. MCCAULEY DATE: 3/27/03

REVISIONS						SHEET NO.	
NO.	BY:	DATE:	NO.	BY:	DATE:	S-17	
1			3			TOTAL SHEETS	23
2			4				