

**IMPORTANT:**  
 THE POWER SHALL BE DELIVERED UNDER GROUND TO THE SIGN STRUCTURE'S VERTICAL UPRIGHT. NO SERVICE POLE SHALL BE INSTALLED UNLESS SPECIFICALLY APPROVED BY THE ENGINEER.  
 UTILITY COMPANY SHALL NOT INSTALL LINE POLES WITHIN NCDOT RIGHT OF WAY UNLESS APPROVED BY THE ENGINEER.  
 IF ELECTRICAL SERVICE IS TO BE DELIVERED OVERHEAD:  
 \* WEATHER HEAD TO BE INSTALLED 13' MINIMUM ABOVE GROUND LINE.  
 \* EYE BOLT OR EYE ATTACHMENT TO BE INSTALLED WITH STAINLESS STEEL STRAPS 12" ABOVE WEATHERHEAD FOR OVERHEAD SERVICE CONDUCTOR ATTACHMENT (NO DRILLING ALLOWED)

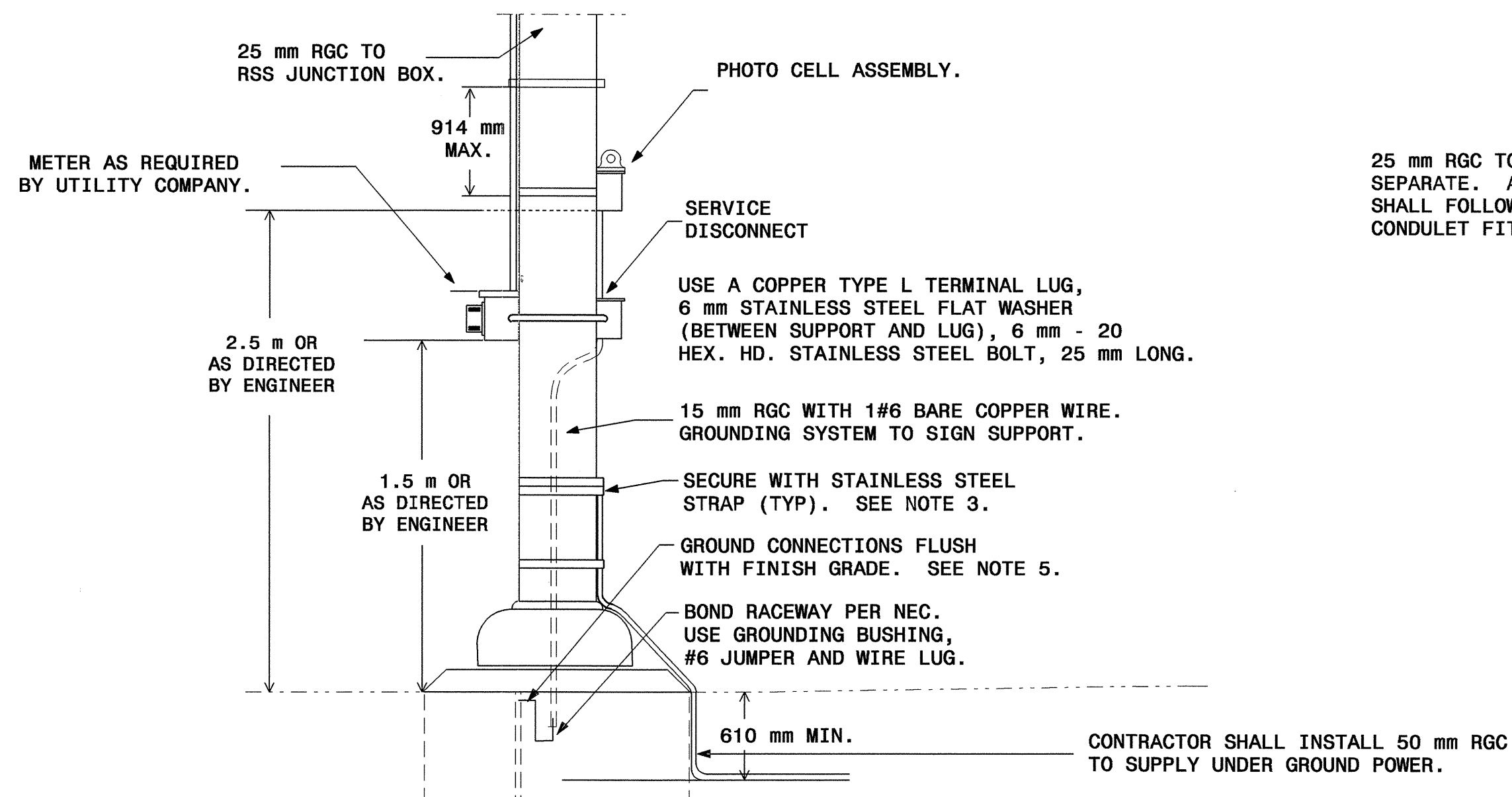

25 mm RGC TO RSS JUNCTION BOX WHERE CIRCUITS SEPARATE. ALL CONDUIT INSTALLED ON STRUCTURE SHALL FOLLOW STRUCTURAL MEMBERS USING 90 DEGREE CONDULET FITTINGS AT EACH 90 DEGREE DIRECTIONAL CHANGE.

NEMA 4X, PADLOCKABLE STAINLESS STEEL ENCLOSURE.

50 mm RGC WITH 3 #6 THWN

"ON-OFF" PHOTO CELL LIGHT CONTROLLER. CONTRACTOR SHALL ORIENT PHOTO CELL SUCH THAT FALSE SWITCHING IS PREVENTED. (SEE PROVISIONS FOR CHARACTERISTICS)

SERVICE DISCONNECT: NEMA 4X PADLOCKABLE STAINLESS STEEL ENCLOSURE WITH ONE 120/240 V DOUBLE POLE, BOLT IN BREAKER.

ELECTRICAL DUCT INSTALLED BY CONTRACTOR WHEN REQUIRED BY SIGNING PLANS.

15 mm RGC WITH 1#6 BARE COPPER WIRE. GROUNDING SYSTEM TO SIGN SUPPORT.

FINISH GROUND LEVEL  
610 mm

VERTICAL "S" PREVENTS DAMAGE FROM EARTH SETTLING.

CONTRACTOR SHALL INSTALL 50 mm RGC TO SUPPLY UNDER GROUND POWER.

VIEW B-B

- NOTES:
1. THE CONTRACTOR SHALL BE REQUIRED TO SUBMIT TO THE N.C.D.O.T. FOR APPROVAL, DETAIL DRAWINGS OF PROPOSED BRACKET(S) FOR SUPPORTING LIGHT FIXTURE(S).
  2. CAULK ALL ENDS OF CONDUIT UNDERGROUND WITH A CAULKING COMPOUND APPROVED BY THE ENGINEER.
  3. STRAPS SHALL BE STAINLESS STEEL MATERIAL UNLESS OTHERWISE SPECIFIED.
  4. ALL JUNCTION BOXES AND CONDULETS SHALL BE WATER TIGHT.
  5. ALL GROUNDING ELECTRODES SHALL BE 3M LONG AND 16 mm IN DIAMETER COPPER CLAD STEEL RODS DRIVEN A MINIMUM DEPTH OF 915 mm INTO UNDISTURBED EARTH.
  6. TEST GROUNDING SYSTEM USING AN APPROVED METHOD. SYSTEM SHOULD MEASURE LESS THAN TWENTY (20) OHMS. IF THE RESISTANCE MEASUREMENT IS GREATER THAN 20 OHMS, ADDITIONAL GROUND RODS SHALL BE INSTALLED AS DIRECTED BY THE ENGINEER TO FULFILL THIS REQUIREMENT.
  7. ALL UNDERGROUND BONDING OF GROUNDING ELECTRODES AND CONDUCTORS SHALL BE BY AN EXOTHERMIC WELDING PROCESS (CADWELD OR EQUIVALENT).
  8. ALL ASSEMBLIES AND COMPONENTS SHALL BE UL APPROVED. INSTALLATION SHALL MEET NEC REQUIREMENTS AND ALL APPROVED STATE AND LOCAL CODES.
  9. WALKWAY AND HANDRAIL IS NOT REQUIRED.

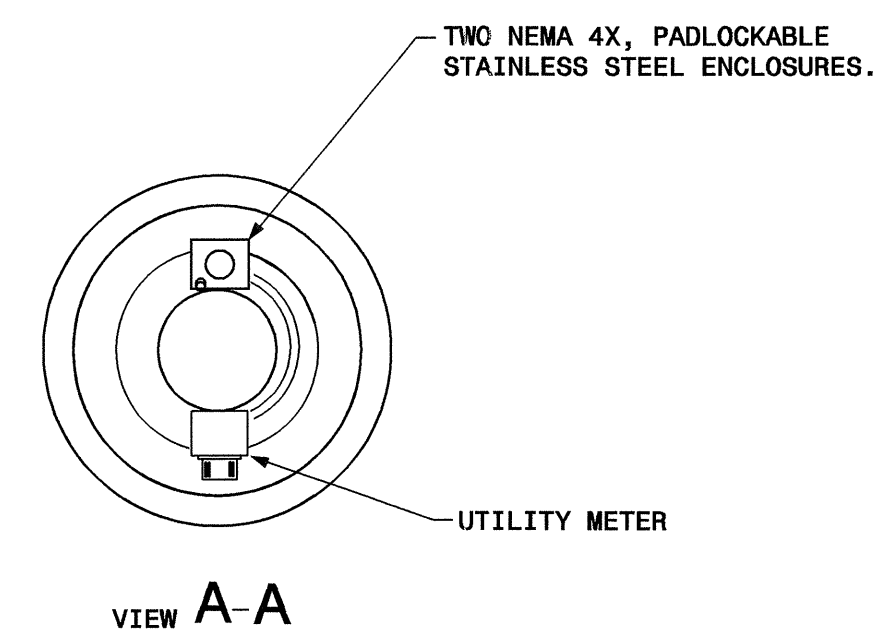

VIEW A-A

LEGEND

- (A) 20 mm STANDARD LB CONDULET.
- (B) 20 mm LIQUID TIGHT FLEXIBLE METALLIC CONDUIT.
- (C) 115 mm X 115 mm X 100 mm RSS JUNCTION CONDULET.
- (D) 20 mm WATERPROOF ADAPTER.
- (E) 20 mm RGC
- (F) STAINLESS STEEL STRAPS.

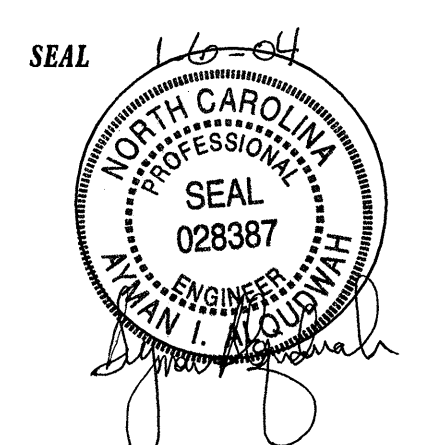

STANDARD LIGHTING SYSTEM FOR OVERHEAD SIGN ASSEMBLIES ( SHEET 1 OF 2 )

SCALE	NONE	N. C. DEPARTMENT OF TRANSPORTATION DIVISION OF HIGHWAYS TRAFFIC ENGINEERING BRANCH	REVISIONS
DATE	01-06-04		
SIGNING TECHNICIAN			
SIGNING ELECTRICAL ENG	M. HOVIOUS		
SIGNING PROJECT ENG	A. ALQUIDWAH		