

PHASING DIAGRAM

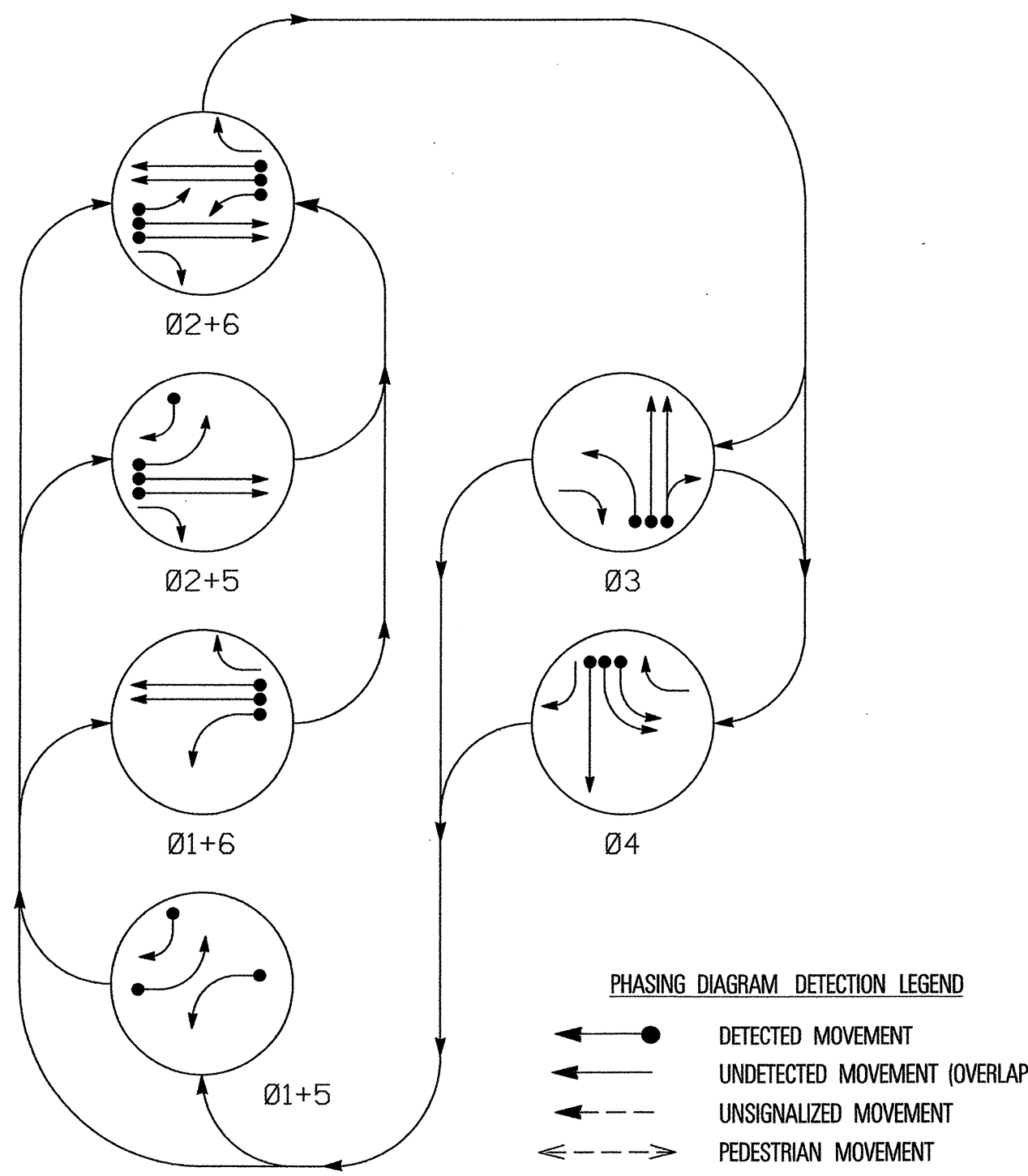
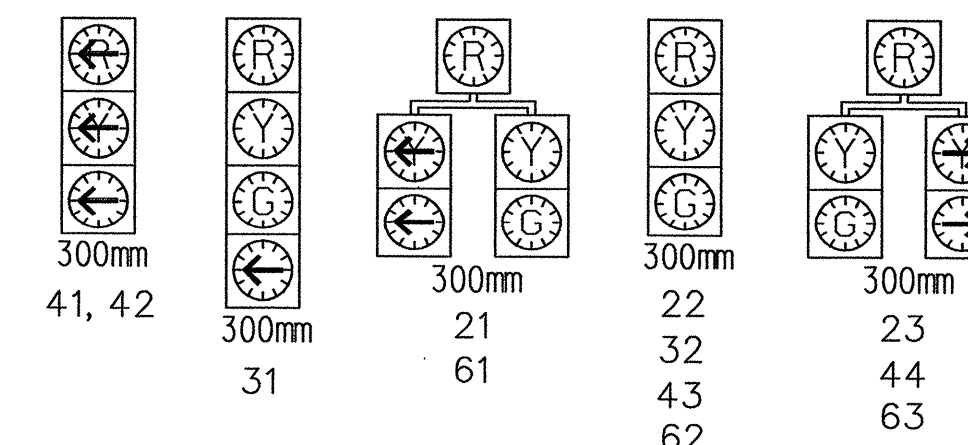

TABLE OF OPERATION

SIGNAL FACE:	PHASE					
	Ø 1 + 5	Ø 2 + 6	Ø 3	Ø 4	Ø 1 + 6	Ø 2 + 5
21	R	R	G	R	R	Y
22	R	R	G	R	R	Y
23	R	R	G	R	R	Y
31	R	R	R	R	G	R
32	R	R	R	R	G	R
41, 42	R	R	R	R	G	R
43	R	R	R	R	G	R
44	R	R	R	R	G	R
61	R	G	R	R	R	Y
62	R	G	R	R	R	Y
63	R	G	R	R	R	Y

SIGNAL FACE I.D.

Denotes L.E.D.



PLAN QUANTITIES

Pay Item	Meters
Signal Cable	270
Messenger Cable	0
Lead-in Cable	1250

6 Phase (Fully Actuated) (Military Cutoff Road Closed Loop System)

NOTES

- Refer to "Roadway Standard Drawings NCDOT" dated January 2002 and "Standard Specifications for Roads and Structures" dated January 2002.
- Pavement markings are existing.
- Omit phase 1 during phase 2 on.
- Omit phase 5 during phase 6 on.
- Program Controller to clear from phase 2+6 to phase 1 and/or 5 by progressing through phase 4 (see Electrical Details).
- Maximum times shown in timing chart are for free-run operation only. Coordinated signal system timing values shall supersede these values.
- During coordination, the order of phase 3 and 4 may be reversed.
- Add Trimble Acutime 2000 (RS-232) GPS Unit for time synchronization until fiber optic cable is installed.
- Remove Trimble Acutime 2000 (RS-232) GPS Unit upon installation of fiber optic cable and actuation of closed loop system.
- Set all detector units to presence mode.
- Closed Loop System Data: Controller Asset #0390.

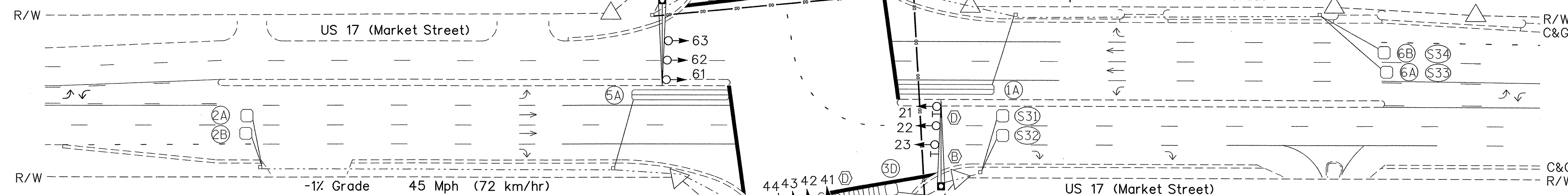

2070L LOOP & DETECTOR INSTALLATION

LOOP	INDUCTIVE LOOPS			DETECTOR PROGRAMMING							NEW CARD
	SIZE (M)	TURNS	DISTANCE FROM STOPBAR (M)	PHASE	CALLING	EXTENSION	FULL TIME DELAY	SYSTEM LOOP	STRETCH TIME	DELAY TIME	
1A	1.8X1.8	2-4-2	0	Y	1	Y	Y	-	-	15	Y
2A	1.8X1.8	5	90	Y	2	Y	Y	-	-	-	Y
2B	1.8X1.8	5	90	Y	2	Y	Y	-	-	-	Y
3A	1.8X1.8	2-4-2	0	Y	3	Y	Y	-	-	-	Y
3B	1.8X1.8	2-4-2	0	Y	3	Y	Y	-	-	-	Y
3C	1.8X1.8	2-4-2	0	Y	3	Y	Y	-	-	10	Y
3D	1.8X1.8	3	0	Y	3	Y	Y	-	-	20	Y
4A	1.8X1.8	2-4-2	0	Y	4	Y	Y	-	-	-	Y
4B	1.8X1.8	2-4-2	0	Y	4	Y	Y	-	-	-	Y
4C	1.8X1.8	2-4-2	0	Y	4	Y	Y	-	-	-	Y
5A	1.8X1.8	2-4-2	0	Y	2	Y	Y	Y	-	3	Y
5B	1.8X1.8	2-4-2	0	Y	5	Y	Y	-	-	15	Y
5C	1.8X1.8	3	0	Y	5	Y	Y	-	-	25	Y
6A-S33	1.8X1.8	5	90	Y	6	Y	Y	Y	-	-	Y
6B-S34	1.8X1.8	5	90	Y	6	Y	Y	Y	-	-	Y
S29	1.8X1.8	4	+50	Y	-	-	-	Y	-	-	Y
S30	1.8X1.8	4	+50	Y	-	-	-	Y	-	-	Y
S31	1.8X1.8	4	+50	Y	-	-	-	Y	-	-	Y
S32	1.8X1.8	4	+50	Y	-	-	-	Y	-	-	Y

2070L TIMING CHART

FEATURE	PHASE					
	1	2	3	4	5	6
Min Green 1*	7	12	7	7	7	12
Extension 1*	1.0	6.0	1.0	1.0	1.0	6.0
Max Green 1*	15	45	25	35	15	45
Yellow Clearance	4.0	4.7	4.0	4.0	4.0	4.7
Red Clearance	2.0	1.5	2.5	3.0	2.0	1.5
Walk 1*	-	-	-	-	-	-
Don't Walk 1	-	-	-	-	-	-
Seconds Per Actuation*	-	1.5	-	-	-	1.5
Max Variable Initial*	-	34	-	-	-	34
Time Before Reduction*	-	15	-	-	-	15
Time To Reduce*	-	30	-	-	-	30
Minimum Gap	-	3.0	-	-	-	3.0
Recall Mode	-	MIN RECALL	-	-	-	MIN RECALL
Vehicle Call Memory	-	YELLOW	-	-	-	YELLOW
Dual Entry	-	-	-	-	-	-
Simultaneous Gap	ON	ON	ON	ON	ON	ON

* These values may be field adjusted. Do not adjust Min Green and Extension times for phases 2 and 6 lower than what is shown. Min Green for all other phases should not be lower than 4 seconds.

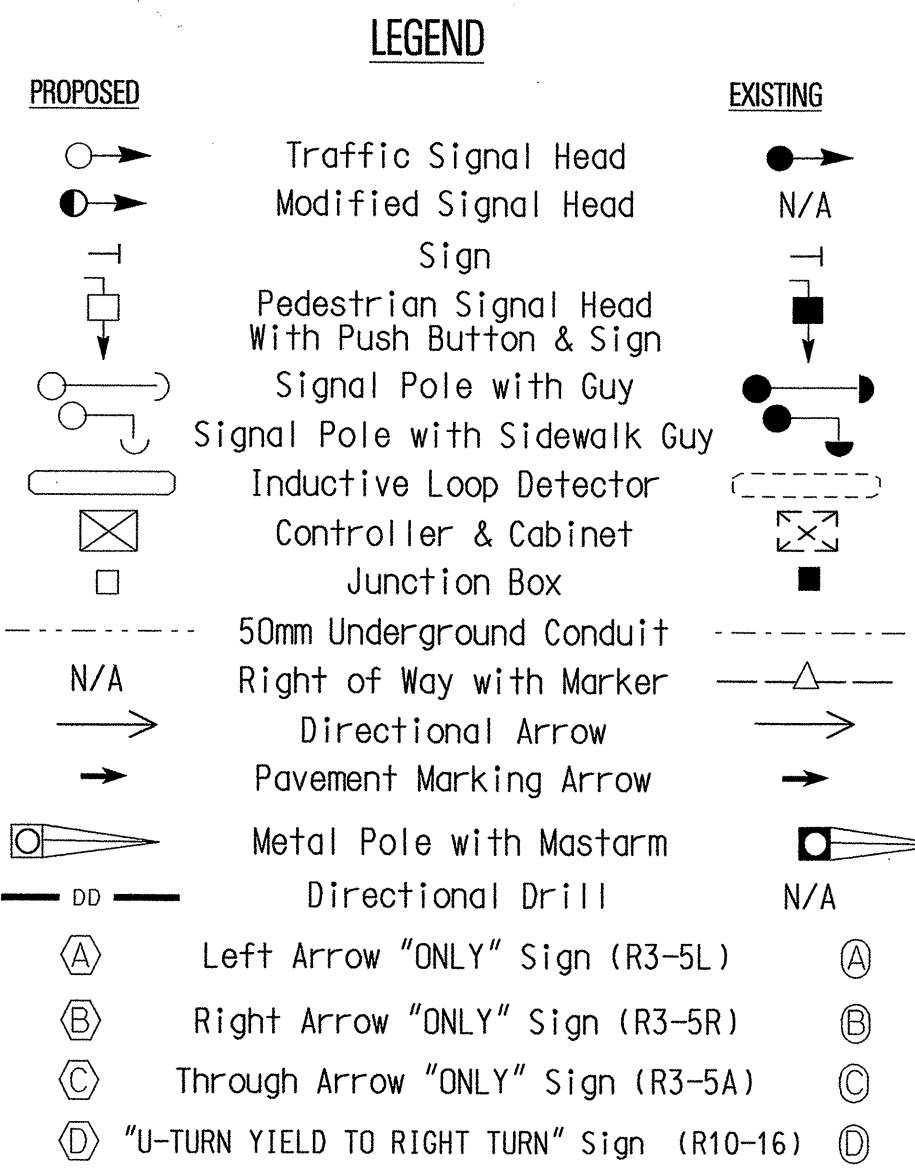

SEPI ENGINEERING GROUP
 2300 Rexwoods Drive
 Suite 370
 Raleigh, NC 27607
 Tel:919-789-9977 Fax:789-9591

Signal Upgrade

Prepared for: Public Works and Safety Services, City of Wilmington, North Carolina

US 17 (Market Street) at SR 2048 (Gordon Road)

Division 3 New Hanover County Wilmington

PLAN DATE: Sept. 2003 REVIEWED BY: L. M. Eddins

PREPARED BY: H. M. Surti REVIEWED BY: S. S. Asefina

REVISIONS: INIT. DATE

SCALE: 1:500

SIGNATURE: [Signature] DATE: 12/11/03

SIG. INVENTORY NO. 03-0390

8448845YSTIME:8448845
 8448845YSTIME:8448845
 8448845YSTIME:8448845