

UTILITIES BY OTHERS

NOTE:
ALL PROPOSED UTILITY WORK
SHOWN ON THIS SHEET WILL
BE DONE BY OTHERS

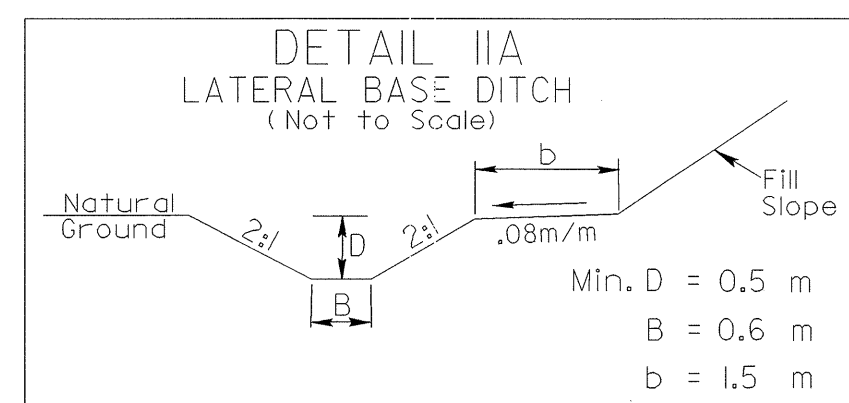

STA. 33+60 -L- TO STA. 33+99 -L- RT

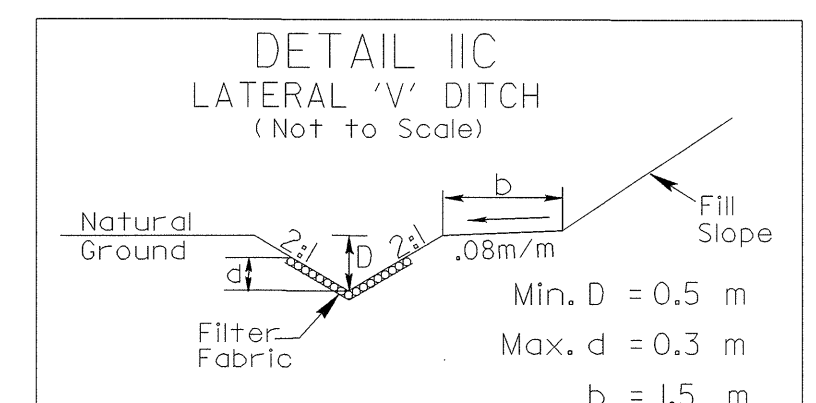

Type of Liner = CL. "B" RIP RAP
STA. 35+84 -L- TO STA. 36+33 -L- LT

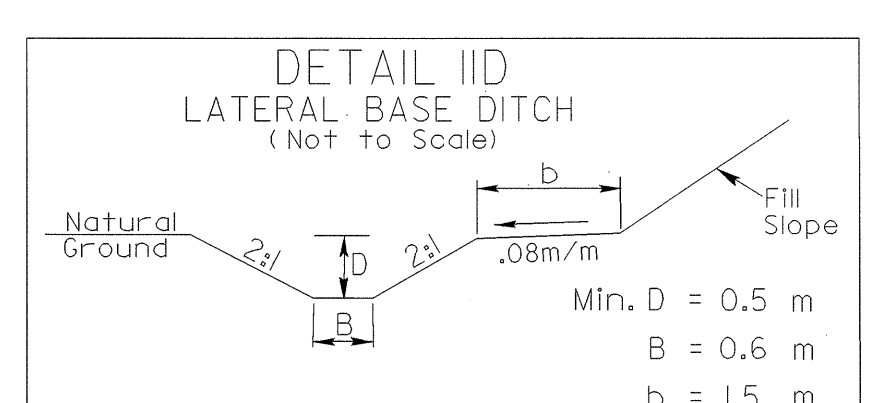

STA. 36+33 -L- TO STA. 37+32 -L- LT

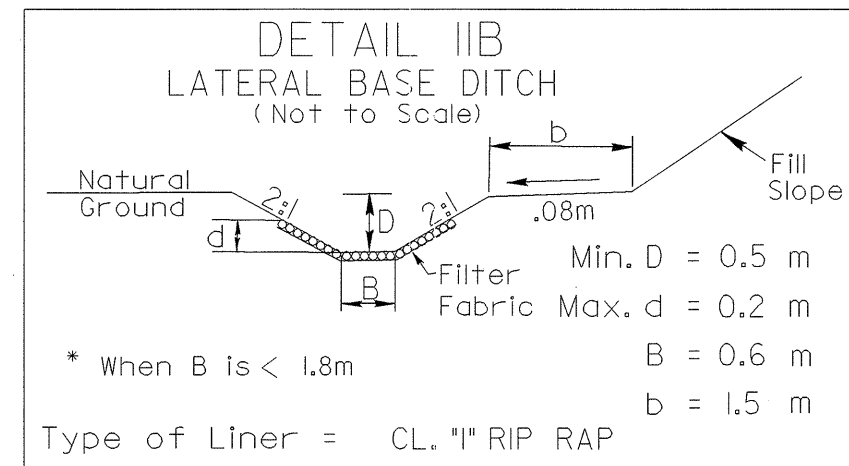

* When B is < 1.8m
Type of Liner = CL. "I" RIP RAP
STA. 33+99 -L- TO STA. 34+34 -L- RT

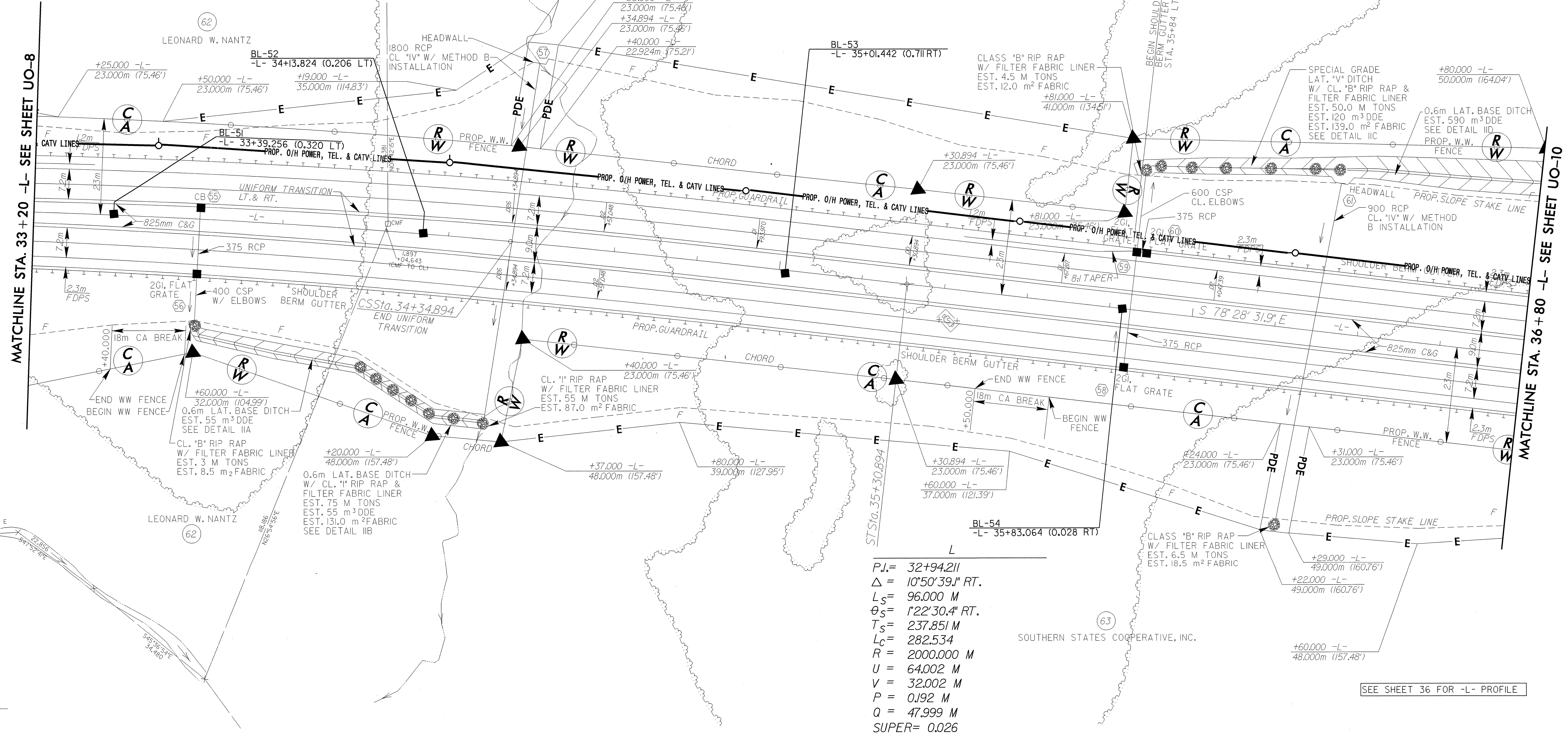

MATCHLINE STA. 33+20 -L- SEE SHEET UO-8

MATCHLINE STA. 36+80 -L- SEE SHEET UO-10

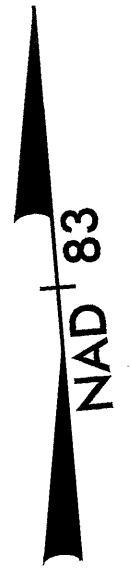

$PJ = 32+94.211$
 $\Delta = 10^{\circ}50'39.1'' \text{ RT.}$
 $L_s = 96.000 \text{ M}$
 $\theta_s = 122^{\circ}30.4'' \text{ RT.}$
 $T_s = 237.851 \text{ M}$
 $L_c = 282.534$
 $R = 2000.000 \text{ M}$
 $U = 64.002 \text{ M}$
 $V = 32.002 \text{ M}$
 $P = 0.192 \text{ M}$
 $Q = 47.999 \text{ M}$
 $\text{SUPER} = 0.026$

SEE SHEET 36 FOR -L- PROFILE