

**RAILROAD PREEMPTION WIRING DETAIL**

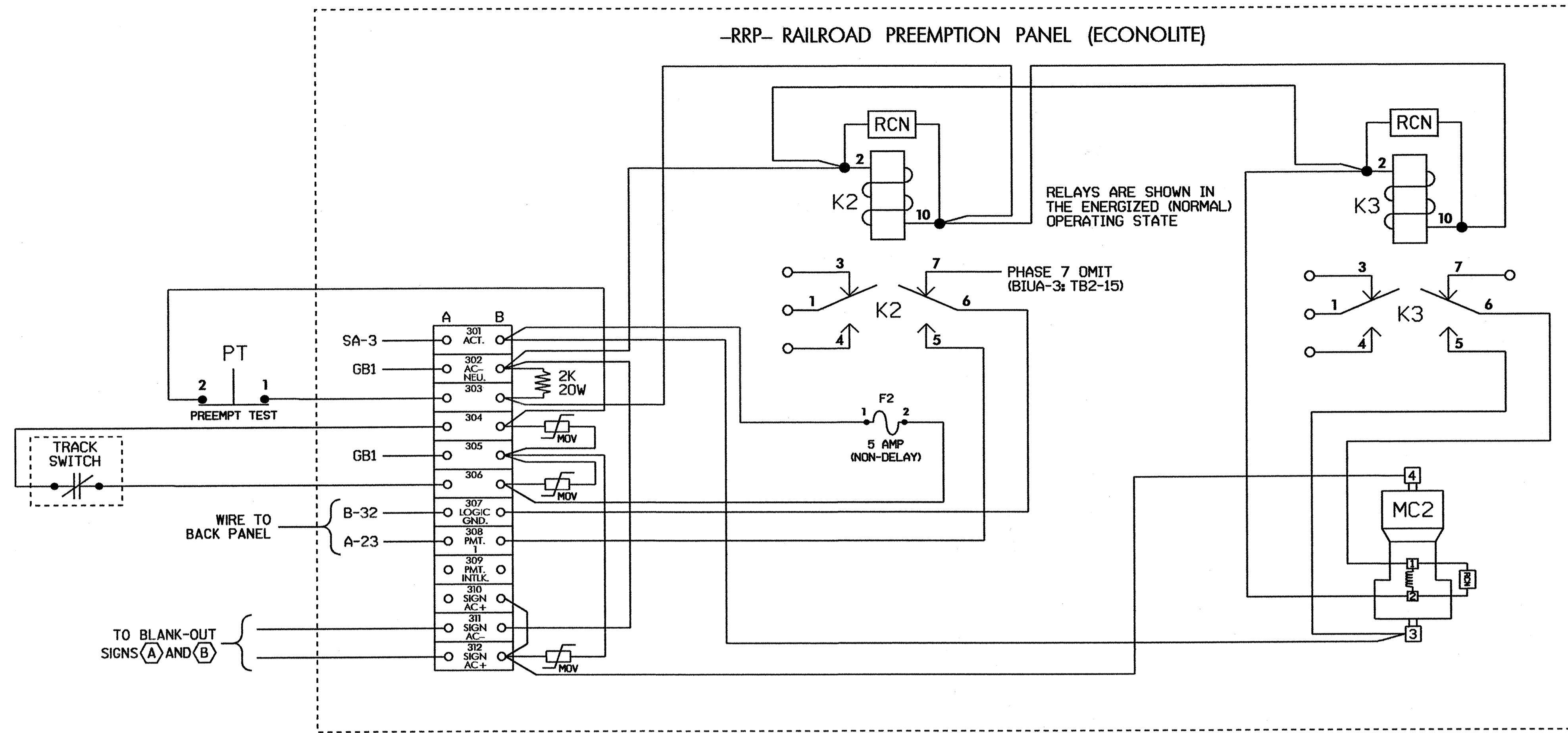

**NOTES**

1. ALL COMPONENTS SHOWN ON 'RRP' PANEL ARE ALREADY IN PLACE, FURNISHED WITH THE PANEL.
2. PREEMPT TEST SWITCH 'PT' IS LOCATED IN AUXILIARY PANEL, FURNISHED WITH THE CABINET.
3. PREEMPT WIRING AND BLANK-OUT SIGN CONTROL WIRING MUST BE AS SHOWN. MODIFY ANY WIRING, IF NECESSARY, TO MATCH WIRING DIAGRAM SHOWN THIS SHEET.



**ECONOLITE ASC2 RAILROAD PREEMPTOR PROGRAMMING DETAIL**  
(program controller as shown below)

PREEMPTOR SUBMENU	
1. PRIORITY PMT 1	5. PRIORITY PMT 5
2. PRIORITY PMT 2	6. PRIORITY PMT 6
3. PRIORITY PMT 3	7. BUS PREEMPTORS
4. PRIORITY PMT 4	

PRIORITY PREEMPTOR 1	
DON'T OVERRIDE FLASH.....	.
FLASH ALL OUTPUTS.....	.
YELLOW-RED GOES GREEN....	.
ENABLE MAX PREEMPT TIME..	.
ACTIVE ONLY DURING HOLD..	.
NO CVM IN FLASH.....	.
FAST FLASH GRN ON HOLD...	.
OUT OF FLASH.....	GREEN
ADDITIONAL PAGE(S)	

PRIORITY PREEMPTOR 1	
PHASE.....	1 2 3 4 5 6 7 8 9 0 1 2
TERM PHASE OVLP .....	
TRK CLR PHASE..	. . . X . . X . . . . .
HOLD PHASES....	. X . . . X . . . . .
EXIT PHASES....	. . . X . . . X . . . . .
EXIT CALLS.....	
TERM OVERLAP... A: . B: . C: . D: .	
ACTIVE.....YES	PED DARK..... NO
PRIORITY.....YES	PED ACTIVE..... NO
DET LOCK.....NO	ZERO PC TIME... NO
HOLD FLASH....NO	PC THRU YELLOW. NO
TERM OVLP ASAP. NO	TERM PHASES.... NO
ADDITIONAL PAGE(S)	

PRIORITY PREEMPTOR 1	
MAX TIME.....	0 DURATION TIME.. 0
MIN HOLD TIME. 12	DELAY TIME..... 0
MIN PED CLEAR. 0	INHIBIT TIME... 0
EXIT MAX.....	0 HLD DELAY TIME. 1
	GRN YEL RED
MINIMUM.....	1 5.4 1.5
TRACK CLEAR... 12	5.4 1.5
HOLD.....	4.7 1.5
END OF SUBMENU	

THIS ELECTRICAL DETAIL IS FOR THE TEMPORARY SIGNAL DESIGN: 12-1137T  
 DESIGNED: AUGUST 2002\*  
 SEALED: 1-27-03\*  
 REVISED: N/A

\*BY ARCADIS G & M OF NORTH CAROLINA, INC.  
 801 CORPORATE CENTER DRIVE, SUITE 300  
 RALEIGH, NC 27607-5073  
 TEL: 919/854-1282 FAX: 919/854-5448

TS-2 TYPE 1 CABINET

TEMPORARY DESIGN

**ELECTRICAL DETAIL - SHEET 2 of 2**

ELECTRICAL AND PROGRAMMING DETAILS FOR: Prepared in the Office of:  STATE OF TRANSPORTATION Signal Management Section 222 N. McDowell St., Raleigh, NC 27603	US 70 at SR 2318 (SHILOH CHURCH/FANJOY ROAD)	SEAL NORTH CAROLINA PROFESSIONAL ENGINEER SEAL 022013 GEORGE C. BROWN
	DIVISION 12 IREDELL COUNTY E. of STATESVILLE PLAN DATE: JANUARY 2003 REVIEWED BY: T.J.P. PREPARED BY: F.E. RUSS REVIEWED BY:	REVISIONS INIT. DATE SIGNATURE DATE SIG. INVENTORY NO. 12-1137T