

**EDI MODEL MMU-16E  
MALFUNCTION MANAGEMENT UNIT  
PROGRAMMING DETAIL**  
(program card and set switches as shown below)

NOTE:  
ADD JUMPER AT 1-6 FOR FINAL DESIGN.

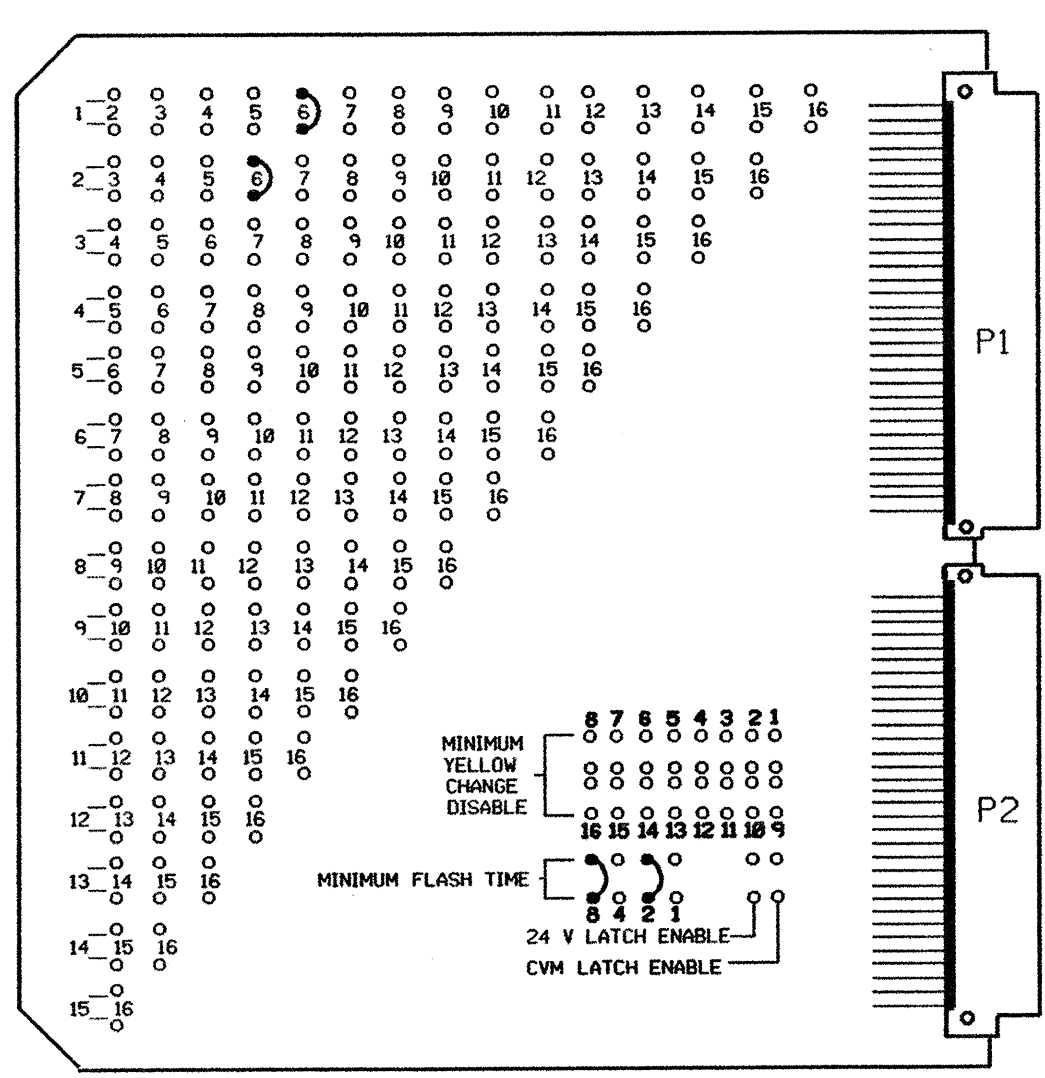

MMU PROGRAMMING CARD

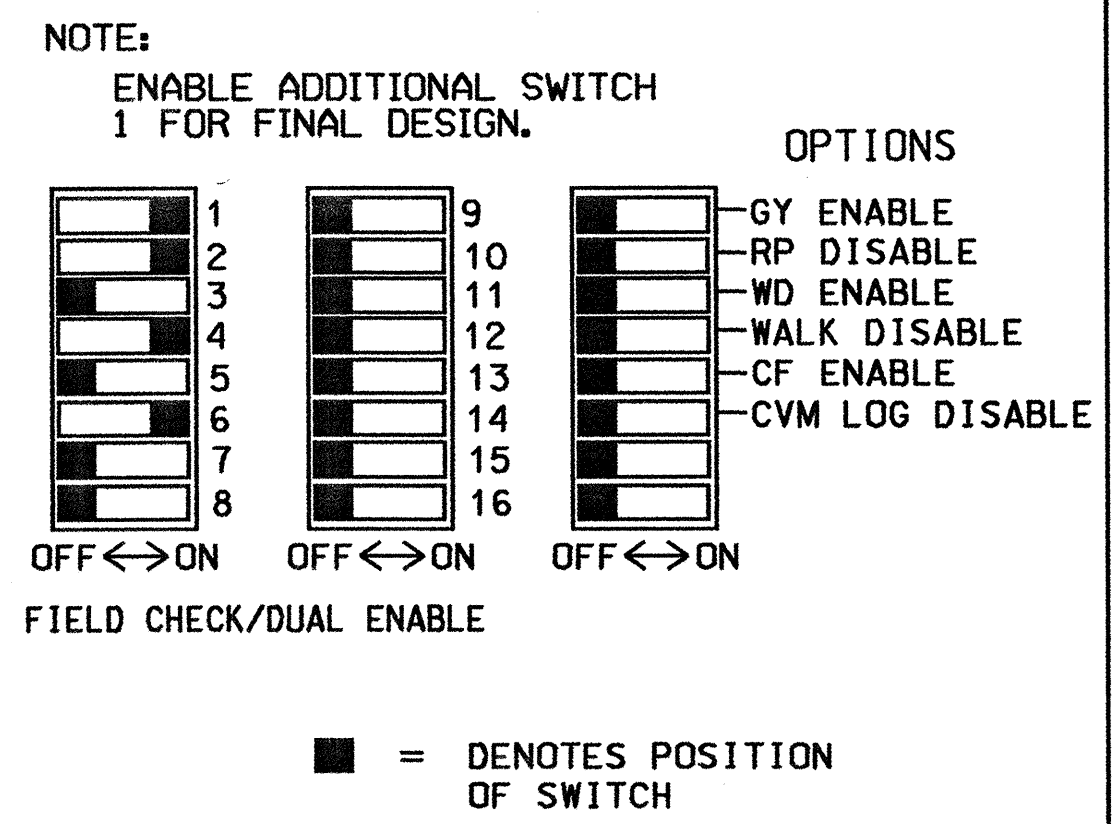

**NOTES**

1. TO PREVENT "FLASH-CONFLICT" PROBLEMS, WIRE ALL UNUSED LOAD SWITCHES TO FLASH RED. VERIFY THAT SIGNAL HEADS FLASH IN ACCORDANCE WITH THE SIGNAL PLANS.
2. TO PREVENT RED FAILURES ON UNUSED MONITOR CHANNELS, TIE UNUSED LOAD SWITCH RED OUTPUTS: 3, 5, 7, 8, 9, 10, 11, & 12 TO LOAD SWITCH AC+ BY INSERTING A JUMPER PLUG IN THE UNUSED LOAD SWITCH SOCKET FROM PIN 1 (LS AC+) TO PIN 3 (RED OUT). MAKE SURE ALL FLASH TRANSFER RELAYS ARE IN PLACE.
3. PROGRAM THE CONTROLLER TO START UP IN PHASES 2 AND 6 GREEN.
4. SET POWER-UP FLASH TIME TO 10 SECONDS AND IMPLEMENT ON THE MALFUNCTION MANAGEMENT UNIT. SET CONTROLLER POWER-UP FLASH TIME TO 0 SECONDS.
5. ENABLE SIMULTANEOUS GAP-OUT FEATURE, ON CONTROLLER UNIT, FOR ALL PHASES.
6. SET ALL DETECTOR CARD UNITS TO 'PRESENCE' MODE.
7. PROGRAM DETECTOR CALL DELAY AND EXTENSION TIMING ON THE CONTROLLER UNLESS OTHERWISE SPECIFIED.
8. THIS CONTROLLER AND CABINET IS TO BE PROGRAMMED AND WIRED AS PART OF AN EXISTING CLOSED LOOP SYSTEM ON US 70. THIS CONTRACTOR IS RESPONSIBLE FOR THE PROPER INTERCONNECTING AND OPERATION OF THIS SIGNAL WITHIN THE SYSTEM.

NOTE:  
ADD NEW LOAD SWITCH IN LOAD BAY POSITION 1 FOR FINAL DESIGN.

**FIELD CONNECTION HOOK-UP CHART**

PHASE	1	2	3	4	5	6	7	8	2 PED	4 PED	6 PED	8 PED
SIGNAL HEAD NO.	42,61	21,22	NU	41,42	NU	61,62	NU	NU	NU	NU	NU	NU
GREEN		2G		4G		6G						
YELLOW		2Y		4Y		6Y						
RED	*	2R		4R		6R						
RED ARROW												
YELLOW ARROW	1Y											
GREEN ARROW	1G											

NU = NOT USED

\*INSTALL LOAD RESISTOR ON LOAD SWITCH 1 RED FIELD TERMINAL. REFER TO LOAD RESISTOR INSTALLATION DETAIL THIS SHEET.

**DETECTOR RACK SET-UP DETAIL**

INSERT DETECTOR CARDS IN RACK ACCORDING TO THE DETAIL SHOWN BELOW. PARTICULAR DETECTOR CHANNELS WILL CALL PHASES INDICATED.

BIU	CH1	CH1	CH1	CH1	CH1	CH1	CH1	CH1	CH1	CH1	CH1	CH1
	L3	L1	L7	L5	SLOT	L9	SLOT	L13	SLOT	SLOT	SLOT	SLOT
	∅2	∅1	∅4	∅2	*	∅6		SYS. DET.				
	CH2	CH2	CH2	CH2	EMPTY	CH2	EMPTY	CH2	EMPTY	EMPTY	EMPTY	EMPTY
	L4	L2	L8	L6		L10		L14				
	∅2	∅6	∅4	NOT USED		∅6		SYS. DET.				

WIRE LOOPS TO TERMINALS ON LOOP PANEL AS SHOWN IN THE CHART BELOW

LOOP NO.	LOOP PANEL TERMINALS
1A	L1A, L1B
	L2A, L2B
2A,2B	L3A, L3B
2C,2D	L4A, L4B
2E	L5A, L5B
	L6A, L6B
4A	L7A, L7B
4B	L8A, L8B
6A,6B	L9A, L9B
6C,6D	L10A, L10B
	L11A, L11B
	L12A, L12B
S22	L13A, L13B
S23	L14A, L14B
	L15A, L15B
	L16A, L16B

**NOTE**  
BE SURE TO PROGRAM DETECTOR TYPES AND TIMERS (EXTEND AND DELAY) AS SHOWN ON THE SIGNAL PLANS.

ASSIGN CONTROLLER SYSTEM DETECTORS TO LOCAL CONT. DET. NUMBERS AS SHOWN IN CHART BELOW

CONTROLLER SYS. DET. NO.	LOCAL CONT. DETECTOR NO.
1	13
2	14
3	
4	
5	
6	
7	
8	

PROGRAM CONTROLLER DETECTORS ACCORDING TO THE SCHEDULE SHOWN IN THE CHART BELOW

CONTROLLER DETECTOR NO.	FUNCTION	TIMING	
		FEATURE	TIME (SEC)
1	∅ 1	DELAY	15
2 *	∅ 6	DELAY	3
3	∅ 2	EXTEND	2.3
4	∅ 2		
5 *	∅ 2	DELAY	3
6			
7	∅ 4	DELAY	3
8	∅ 4	DELAY	15
9	∅ 6	EXTEND	2.3
10	∅ 6		
11			
12			
13	SYSTEM		
14	SYSTEM		
15			
16			

\* THIS DETECTOR IS EQUIPPED WITH DELAY AND EXTEND TIMER. PROGRAM THE TIMING REQUIRED FOR THIS DETECTOR CHANNEL ON THE DETECTOR UNIT, NOT THE CONTROLLER.

**SPECIAL BACK-UP PROTECTION NOTES**

1. PROGRAM CONTROLLER TO OMIT PHASE 1 DURING PHASE 2 ON.
2. TO ACCOMPLISH BACK-UP FEATURE DESCRIBED IN NOTE 1, ENABLE 'BACK-UP PROTECTION GROUP 1' UNDER CONTROLLER SUBMENU 9: 'OPTION DATA'.

**EQUIPMENT INFORMATION**

- \* CONTROLLER.....CONTRACTOR SUPPLIED ECONOLITE ASC/2
- \* CABINET .....CONTRACTOR SUPPLIED ECONOLITE NC-3
- CABINET MOUNT.....BASE
- LOADBAY POSITIONS.....12
- LOAD SWITCHES USED.....1, 2, 4, 6
- PHASES USED.....1, 2, 4, 6
- OL/A.....NOT USED
- OL/B.....NOT USED
- OL/C.....NOT USED
- OL/D.....NOT USED

EXISTING FROM TEMPORARY DESIGN \*

**LOAD RESISTOR INSTALLATION DETAIL**

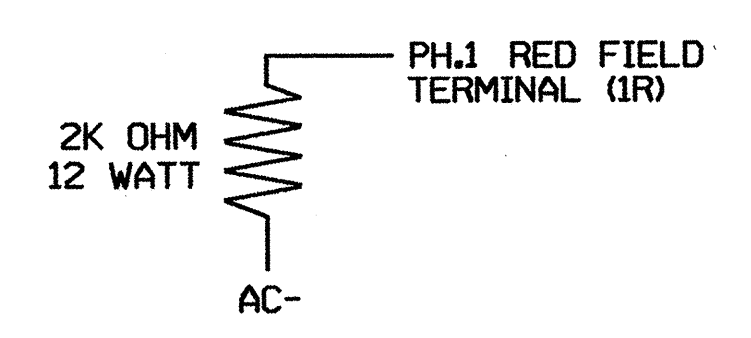

NOTE: THE PURPOSE OF THIS RESISTOR IS TO LOAD THE CHANNEL RED MONITOR INPUT IN ORDER FOR THE MALFUNCTION MANAGEMENT UNIT TO USE THE FULL SIGNAL SEQUENCE MONITORING CAPABILITY ON THIS CHANNEL, WHICH DOES NOT USE THE RED DISPLAY IN THE FIELD.

**LOAD SWITCH ASSIGNMENT DETAIL**  
(program controller according to schedule in chart below)

LOAD SWITCH NUMBER	FUNCTION
1	∅ 1
2	∅ 2
3	∅ 3
4	∅ 4
5	∅ 5
6	∅ 6
7	∅ 7
8	∅ 8
9	∅ 2 PED
10	∅ 4 PED
11	∅ 6 PED
12	∅ 8 PED

THIS ELECTRICAL DETAIL IS FOR THE SIGNAL DESIGN: 12-1692  
DESIGNED: AUGUST 2002\*  
SEALED: 1-27-03\*  
REVISED: N/A

\* BY ARCADIS G & M OF NORTH CAROLINA, INC.  
801 CORPORATE CENTER DRIVE, SUITE 300  
RALEIGH, NC 27607-5073  
TEL: 919/854-1282 FAX: 919/854-5448

TS-2 TYPE 1 CABINET

CLOSED LOOP DATA :

INTERSECTION NUMBER	10
LOCAL TELEMETRY ADDRESS	10
CHANNEL NUMBER	2

**FINAL DESIGN**

ELECTRICAL AND PROGRAMMING DETAILS FOR:

US 70  
at  
SR 2359 (BETHESDA RD.)

DIVISION 12 IREDELL COUNTY E. of STATESVILLE

PLAN DATE: JANUARY 2003 REVIEWED BY: T. J. J. J.

PREPARED BY: F. E. RUSS REVIEWED BY:

REVISIONS	INIT.	DATE

SEAL

STATE OF NORTH CAROLINA

PROFESSIONAL ENGINEER

022013

GEORGE C. BROWN

DATE: 1/27/03

SIG. INVENTORY NO. 12-1692