

**PLAN (STAGE 1)**

(FOR CLARITY, SHEET PILES NOT SHOWN)

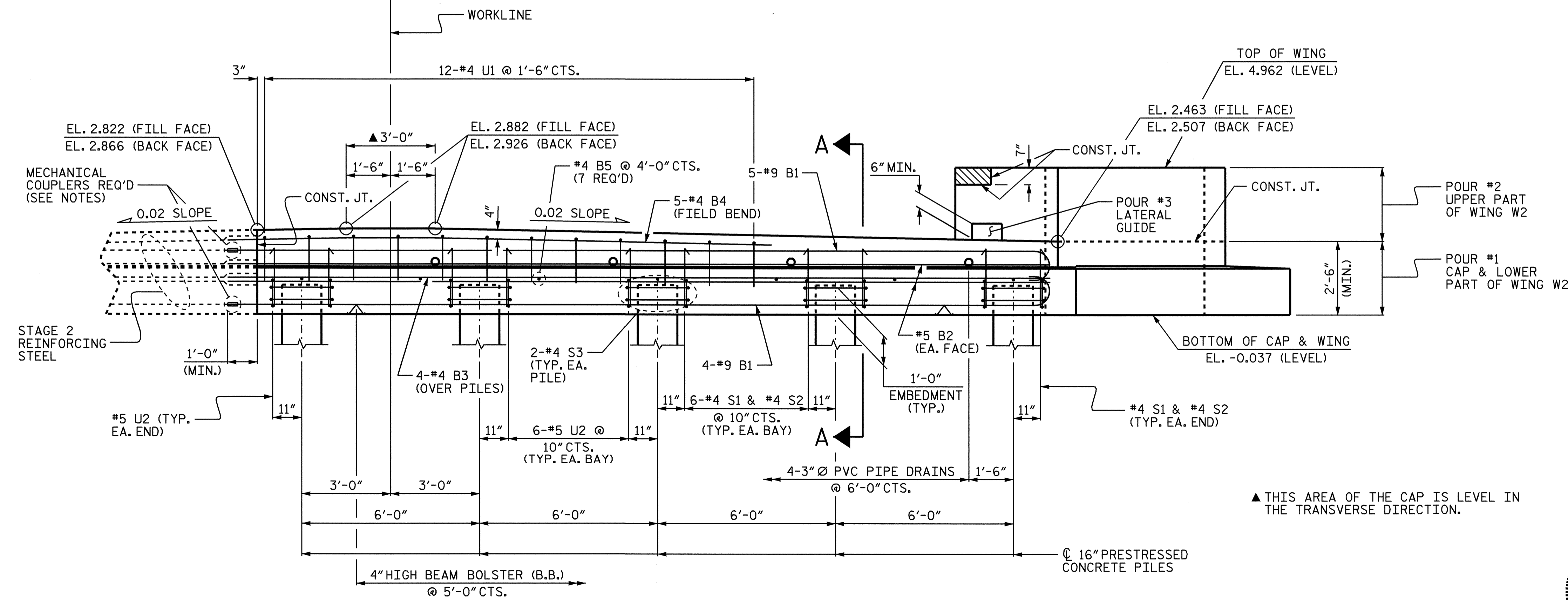

**ELEVATION (STAGE 1)**

(FOR CLARITY, SHEET PILES NOT SHOWN)

**NOTES:**

STIRRUPS AND U1 BARS IN CAP MAY BE SHIFTED AS NECESSARY TO CLEAR DOWELS.

ALL REINFORCING STEEL AND BAR SUPPORTS SHALL BE EPOXY COATED ACCORDING TO THE STANDARD SPECIFICATIONS.

PIPE DRAINS MAY BE SHIFTED SLIGHTLY AS NECESSARY TO CLEAR REINFORCING STEEL AND DOWELS.

CLASS AA CONCRETE SHALL BE USED IN THE END BENT CAP.

THE CONCRETE IN THE SHADED AREA OF THE WINGS SHALL BE POURED AFTER THE PARAPET AND END POST ARE CAST IF SLIP FORMING IS USED.

THE LATERAL GUIDE AT EACH END OF THE CAP IS NOT TO BE POURED UNTIL AFTER THE CORED SLAB UNITS IN THAT STAGE ARE IN PLACE.

THE CONTRACTOR SHALL PROVIDE FOR INSTALLATION OF THE 4" DIAMETER DRAIN PIPE THROUGH THE WING WALL AS REQUIRED FOR REINFORCED BRIDGE APPROACH FILLS, SEE THE ROADWAY PLANS. REINFORCING STEEL IN THE WING WALL MAY BE SHIFTED AS NECESSARY TO CLEAR THE DRAIN PIPE.

THE CONTRACTOR'S ATTENTION IS CALLED TO THE FACT THAT THE LENGTHS OF THE #9 "B" BARS AT THE STAGED CONSTRUCTION JOINT MAY NEED TO BE ADJUSTED DUE TO THE TYPE OF MECHANICAL BUTT SPLICE CHOSEN BY THE CONTRACTOR. NO ADDITIONAL PAYMENT WILL BE MADE FOR ANY ADJUSTMENTS REQUIRED.

MECHANICAL COUPLERS SHALL BE USED TO JOIN THE #9 B1 BARS IN STAGE 1 WITH THE #9 B8 BARS IN STAGE 2. THE LOCATION OF THE COUPLERS SHALL BE STAGGERED ON ALTERNATING BARS BY 1 FOOT AND THE #9 B1 AND B8 BARS SHALL BE CUT ACCORDINGLY TO ALLOW A MINIMUM OF 1'-0" AND A MAXIMUM OF 2'-0" EXTENSION INTO STAGE 2 CONSTRUCTION.

FOR MECHANICAL BUTT SPLICES FOR REINFORCING STEEL, SEE SPECIAL PROVISIONS.

CONCRETE DISPLACED BY THE 16" PRESTRESSED CONCRETE PILES HAS BEEN DEDUCTED FROM THE CONCRETE QUANTITY.

ALL STEEL SHEET PILES SHALL BE ASTM A690 MARINE GRADE STEEL.

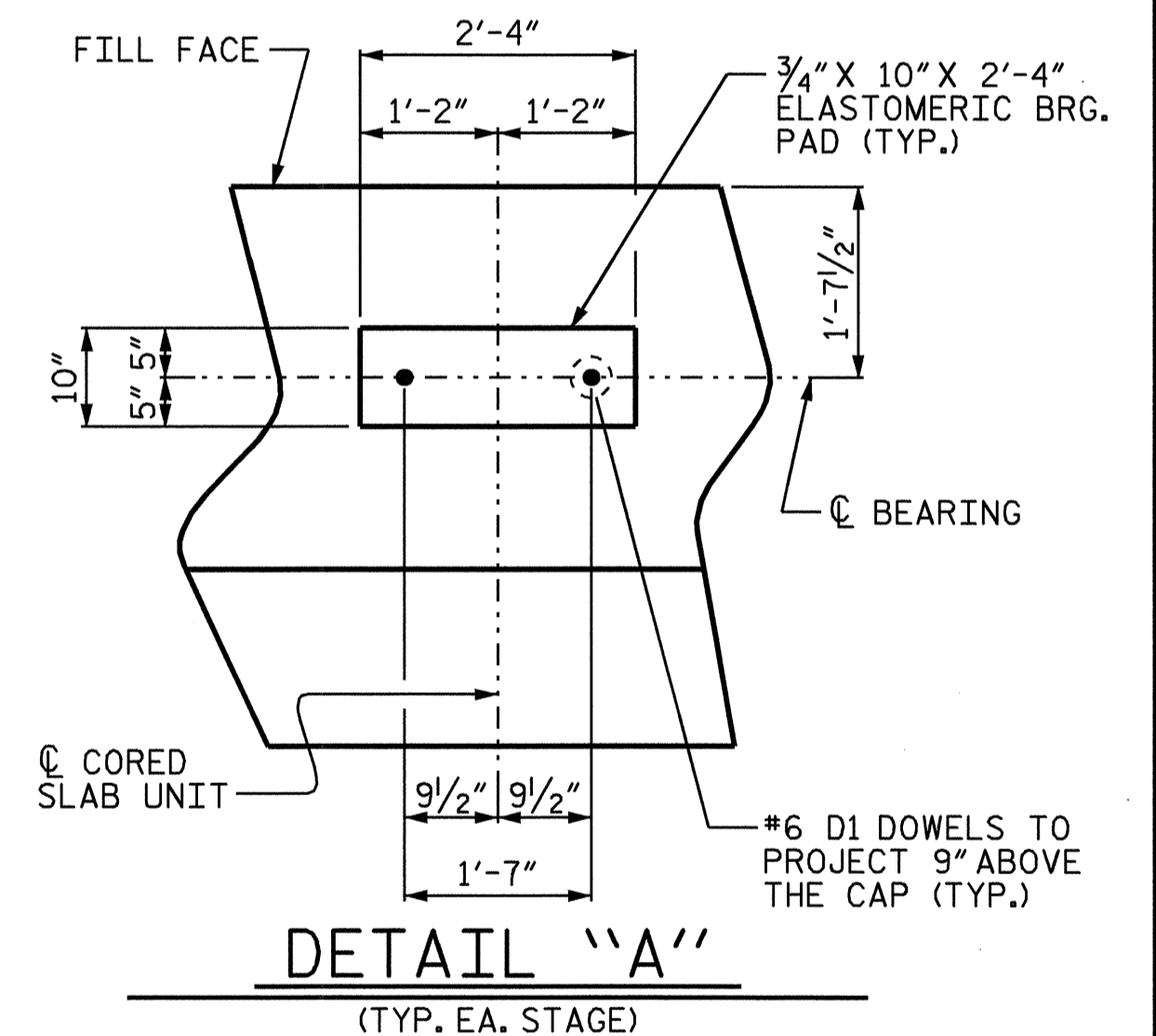

PROJECT NO. **B-3348**  
 COUNTY **HYDE**  
 STATION: **18+34.00 -L-**

SHEET 2 OF 6

STATE OF NORTH CAROLINA  
 DEPARTMENT OF TRANSPORTATION  
 RALEIGH

**SUBSTRUCTURE  
 END BENT No. 2  
 STAGE 1**

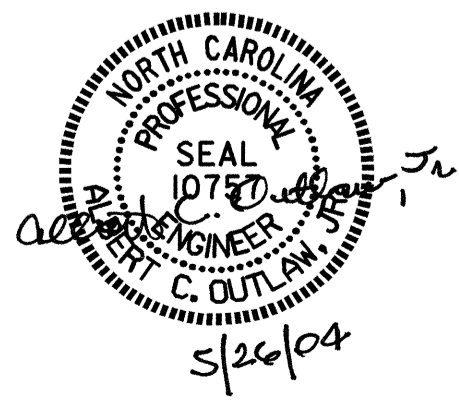

DRAWN BY: **P.C. BREWER** DATE: **3/2/04**  
 CHECKED BY: **C.H. STIMPSON** DATE: **4/5/04**

REVISIONS						SHEET NO.	
NO.	BY:	DATE:	NO.	BY:	DATE:	S-24	
1			3			TOTAL SHEETS	
2			4			76	