

@ END BENT 1

PLAN

@ END BENT 2

\* RADIAL DIMENSIONS

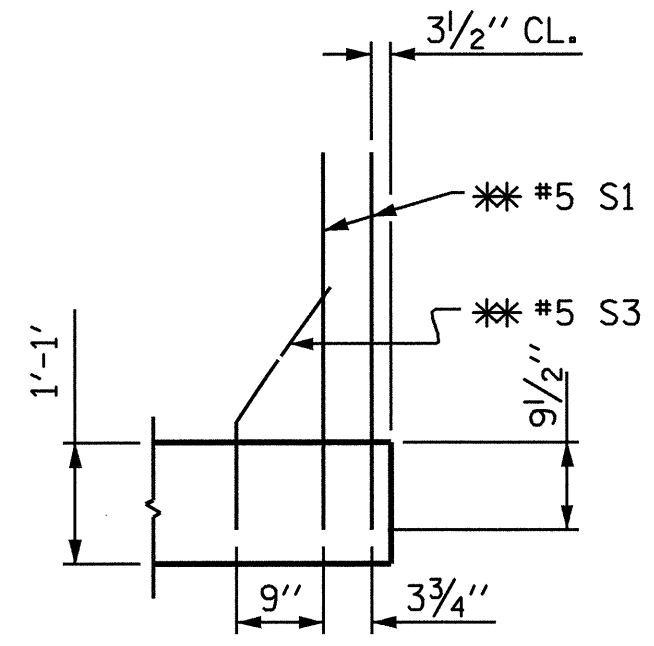

SECTION K-K  
\*\* ADHESIVELY ANCHORED

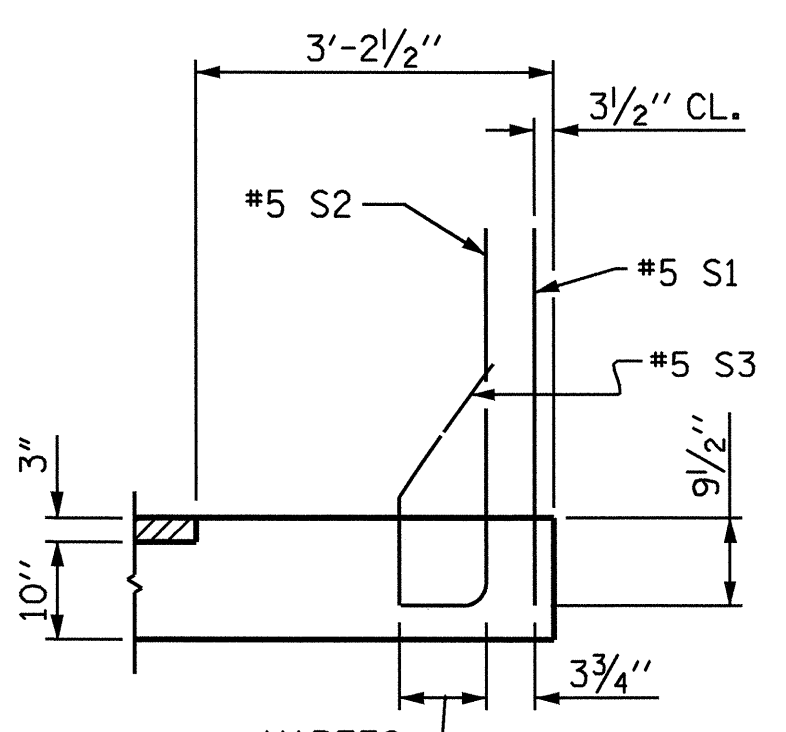

SECTION L-L  
VARIES

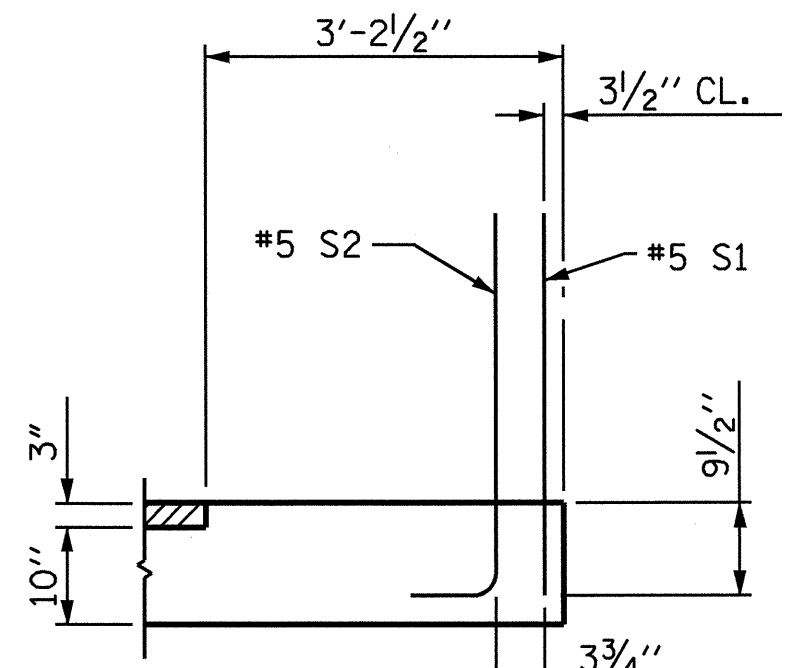

SECTION M-M

PROJECT NO. B-3649  
GUILFORD COUNTY  
 STATION: 17+39.20 -L-

SHEET 1 OF 4

STATE OF NORTH CAROLINA  
 DEPARTMENT OF TRANSPORTATION  
 RALEIGH  
 STANDARD  
 BRIDGE APPROACH SLAB  
 FOR FLEXIBLE PAVEMENT  
 WITH BARRIER RAIL

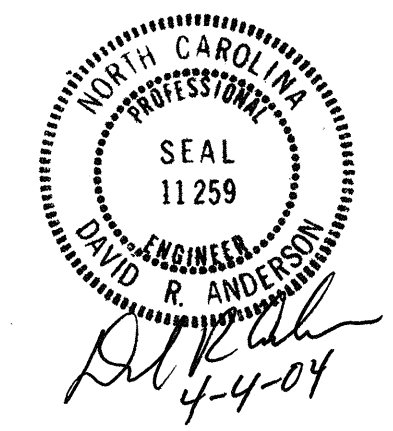

| REVISIONS |     |       |     |     |       | SHEET NO.    |
|-----------|-----|-------|-----|-----|-------|--------------|
| NO.       | BY: | DATE: | NO. | BY: | DATE: | 5-29         |
| 1         |     |       | 3   |     |       | TOTAL SHEETS |
| 2         |     |       | 4   |     |       | 32           |

DRAWN BY: M.A. ALLEN DATE: 2-04  
 CHECKED BY: W.K. FISCHER DATE: 2-25-04