

DETAIL NO. 1

MAP NO. 10, BRIDGE NO. 82  
 SEE CHART ON BELOW FOR EXISTING  
 BRIDGE PAVING INSTRUCTIONS

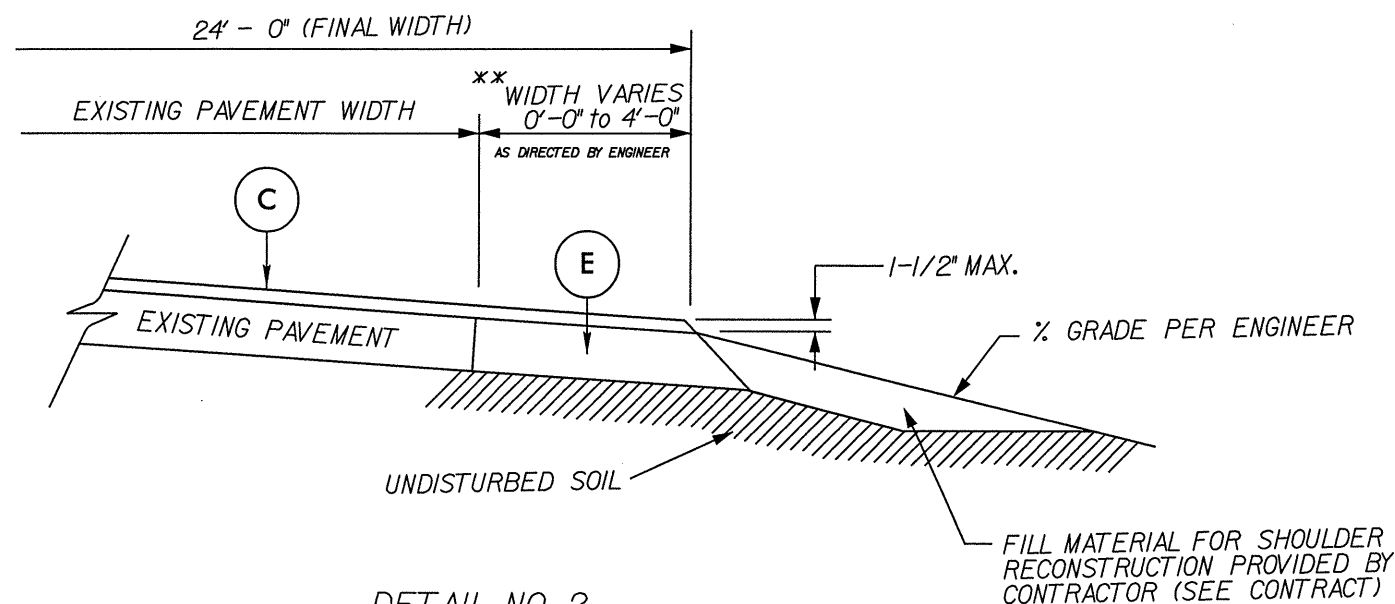

DETAIL NO. 2

WIDENING AND SHOULDER RECONSTRUCTION  
 (MAP 2 ONLY)

NOTE TO CONTRACTOR:

IT IS STRONGLY RECOMMENDED THAT ONE FOOT WIDENING NOT BE USED AS IT IS VERY DIFFICULT TO ACHIEVE PROPER COMPACTION IN SUCH A SMALL AREA.

AS DIRECTED BY THE ENGINEER, THE CONTRACTOR MAY BE REQUIRED TO DISTRIBUTE THE WIDENING ON A MAP TO MATCH THE FIELD CONDITIONS. FOR INSTANCE, A MAP WITH 2 TO 3 FT. WIDENING MAY HAVE 0 FT WIDENING ON ONE SIDE OF THE ROADWAY AND 2 OR 3 FT WIDENING ON THE OTHER SIDE. LIKEWISE, ON A MAP WITH 4 FT WIDENING, THERE MAY BE 0 FT WIDENING ON ONE SIDE AND 4 FT WIDENING ON THE OTHER SIDE, OR IT MAY BE DIVIDED UP EQUALLY HAVING 2 FT WIDENING ON BOTH SIDES OF THE ROADWAY. AS STATED, THIS WILL DEPEND ON FIELD CONDITIONS AND WILL BE AT THE DISCRETION OF THE ENGINEER.