

* THE ENGINEER SHALL VERIFY THAT THE LOCATION OF THE CONCRETE FLUME DOES NOT CONFLICT WITH THE PLACEMENT OF THE GUARDRAIL POST.
 * @ MODIFIED CONCRETE FLUME (ROADWAY DETAIL & PAY ITEM) (SEE SHEET 4 OF 4 FOR DETAILS)

NOTE: REINFORCING STEEL SHOULD BE FIELD CUT TO MAINTAIN A 50mm MINIMUM CLEARANCE TO THE DROP INLET. SEE ROADWAY PLANS.

PROJECT NO. R-2514A
 ONSLOW COUNTY
 STATION: 182+87.400-L-MED

SHEET 2 OF 4
 STATE OF NORTH CAROLINA
 DEPARTMENT OF TRANSPORTATION
 RALEIGH
 BRIDGE APPROACH SLAB FOR PRESTRESSED CONCRETE CORED SLAB WITH BARRIER RAIL (RIGHT LANE)

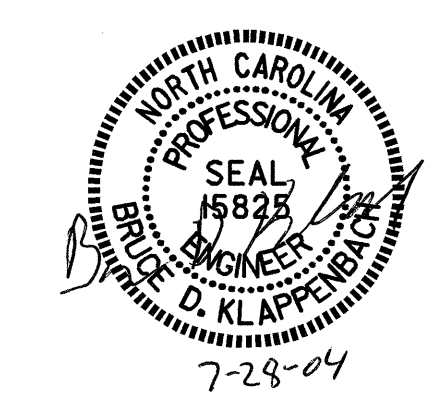

REVISIONS						SHEET NO.	
NO.	BY:	DATE:	NO.	BY:	DATE:	TOTAL SHEETS	
1			3			5-44	46
2			4				

DRAWN BY: J.B. WILSON DATE: 4/04
 CHECKED BY: G.M. PATTERSON DATE: 4/04

27-JUL-2004 11:18
 w:\squad\R2514a\Strland2\jwilson\Microstation\R-2514a.sd..AS..02.dgn
 bklappenbach

STR. #2

PLAN

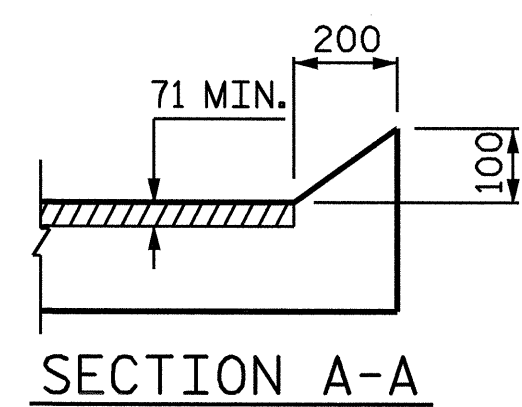

AT END BENT #1

AT END BENT #2