



PROJ. REFERENCE NO.	SHEET NO.
R-2514A	PM-3

115+00

116+00

117+00

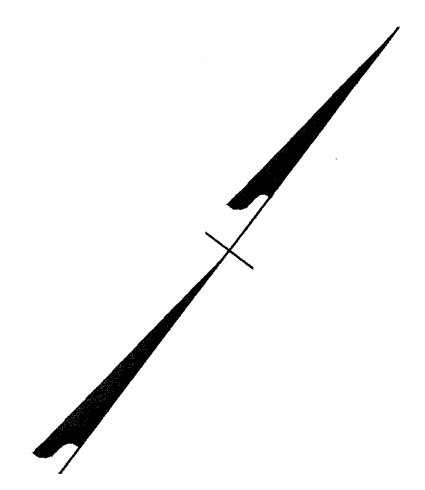

BREAK LINE SEE SHEET PM-2

BREAK LINE SEE SHEET PM-4

PROP. US 17 SB -L MED-

PROP. US 17 NB -L MED-

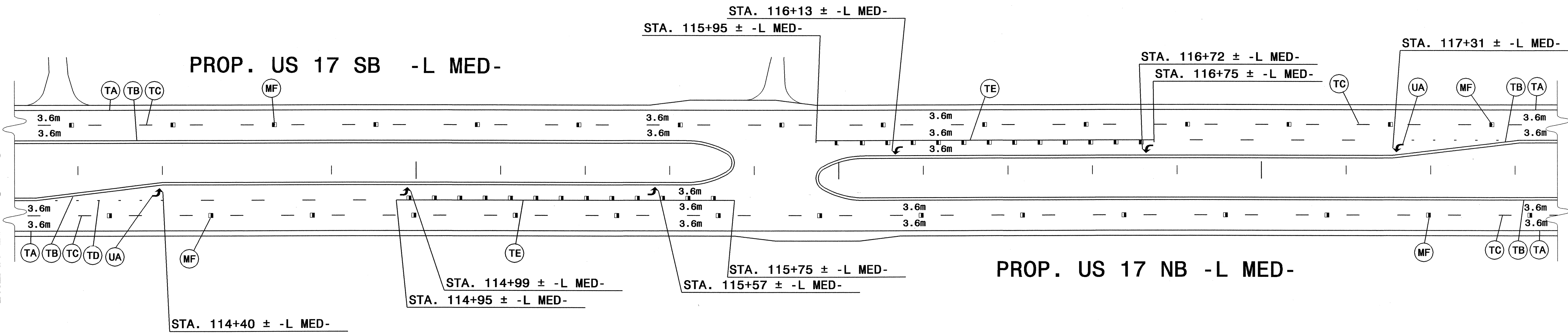

23-NOV-2003 2:04:17  
G:\CAD\2003\0001 R-2514A\Traffic\TrafficControl\TCP\R-2514A\_TC\_PM03.dgn  
Dunn AT DUNN

APPROVED: _____	DATE: _____	<b>FINAL PAVEMENT MARKING PLAN</b>									
				SCALE: NONE	<table border="1"> <tr><th colspan="2">REVISIONS</th></tr> <tr><td> </td><td> </td></tr> <tr><td> </td><td> </td></tr> <tr><td> </td><td> </td></tr> </table>	REVISIONS					
		REVISIONS									
		DATE: 11/18/03	<table border="1"> <tr><td>CADD FILE</td><td>R-2514A TC PM03.DGN</td></tr> </table>	CADD FILE	R-2514A TC PM03.DGN						
		CADD FILE		R-2514A TC PM03.DGN							
DESIGN BY: KWD	REVIEWED BY: JHJ										