

PROJ. REFERENCE NO.	SHEET NO.
U-3328	TCP-04

- NOTES:
- SPACE DRUMS NO MORE THAN 40 FT APART.
 - SPACE DRUMS 10 FT APART IN RADII.
 - SPACE DRUMS 10 FT APART @ DRIVEWAY ENTRANCES.
 - AFTER WEDGING OF -L- REPLACE MARKINGS IN EXISTING PATTERN.
 - MARKINGS SHOWN ARE APPROXIMATE.

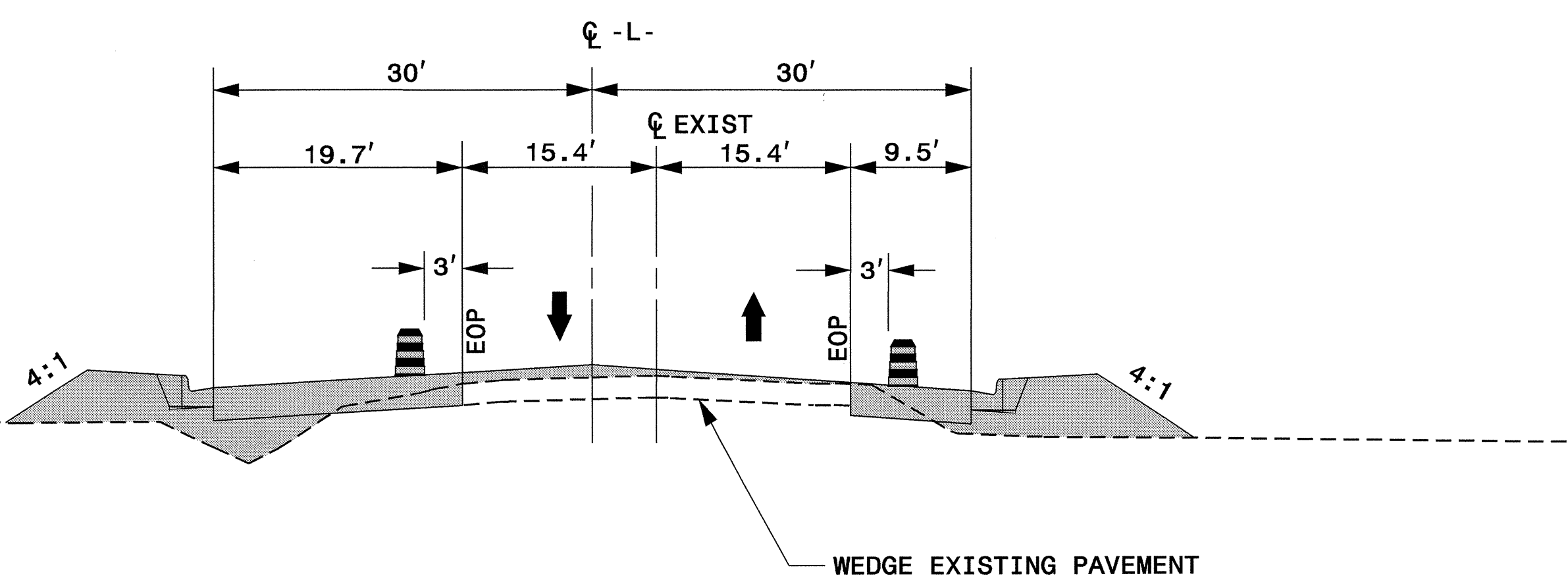
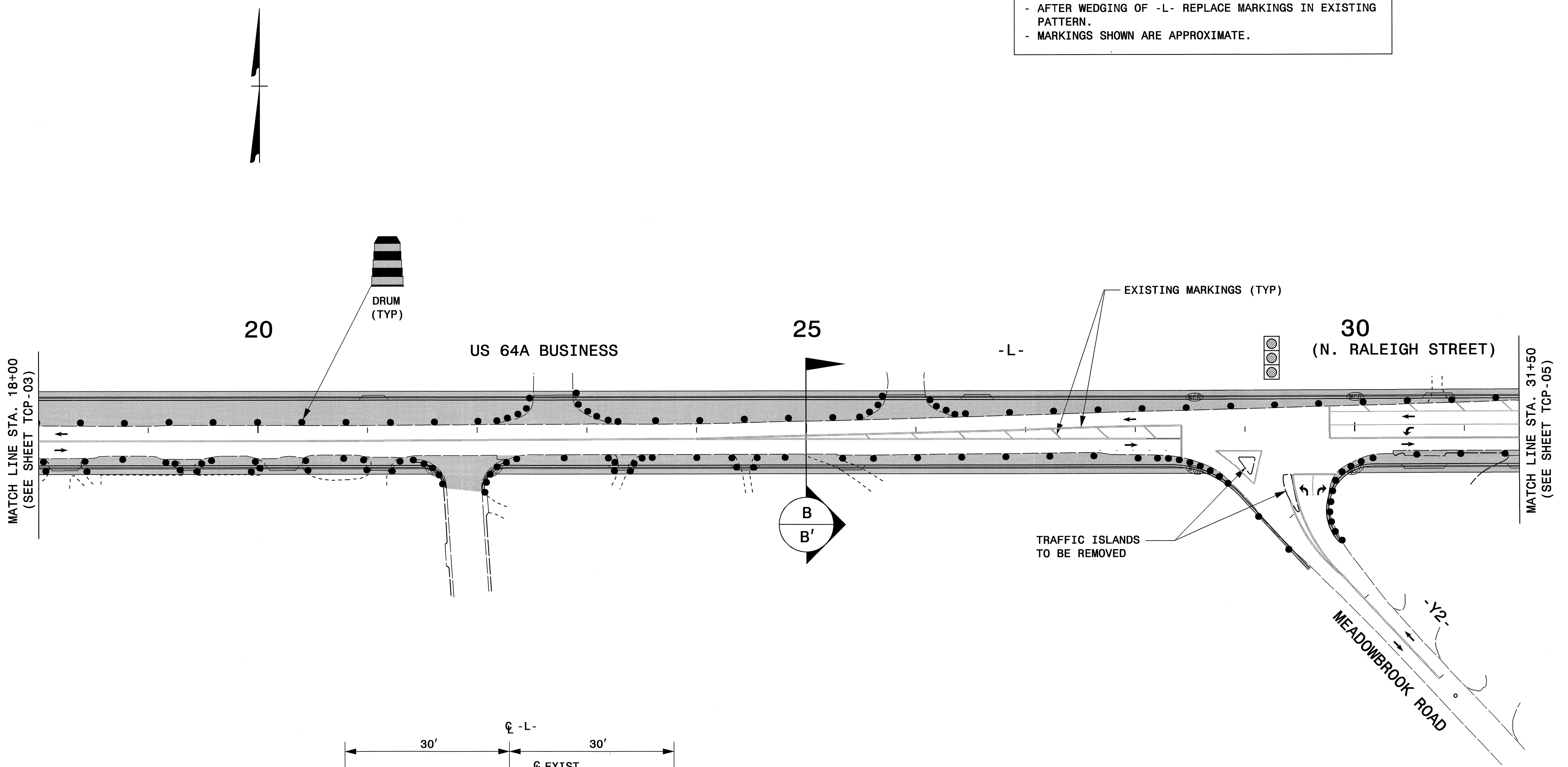

APPROVED: *[Signature]* DATE: 9/21/04

SEAL: NORTH CAROLINA PROFESSIONAL ENGINEER SEAL 022104 JOHN S. KITE, P.E.

PHASE I / II

SCALE: NONE	REVISIONS
DATE: 07/04	
DWG. BY: RMG	
DESIGN BY: RMG	
REVIEWED BY: JDK	

CADD FILE

I7-SEP-2004 09:35
 \\ets-cctfs01\3328\TCP\U3328_TC_TCP04.dgn
 rmgarrett AT TETC06372