

20 APR 2004 11:01 AM \\sers\server\d\stds\02\stds to Special Details\english\86202\0862d02.dgn  
 erl\ward  
 4/29/04

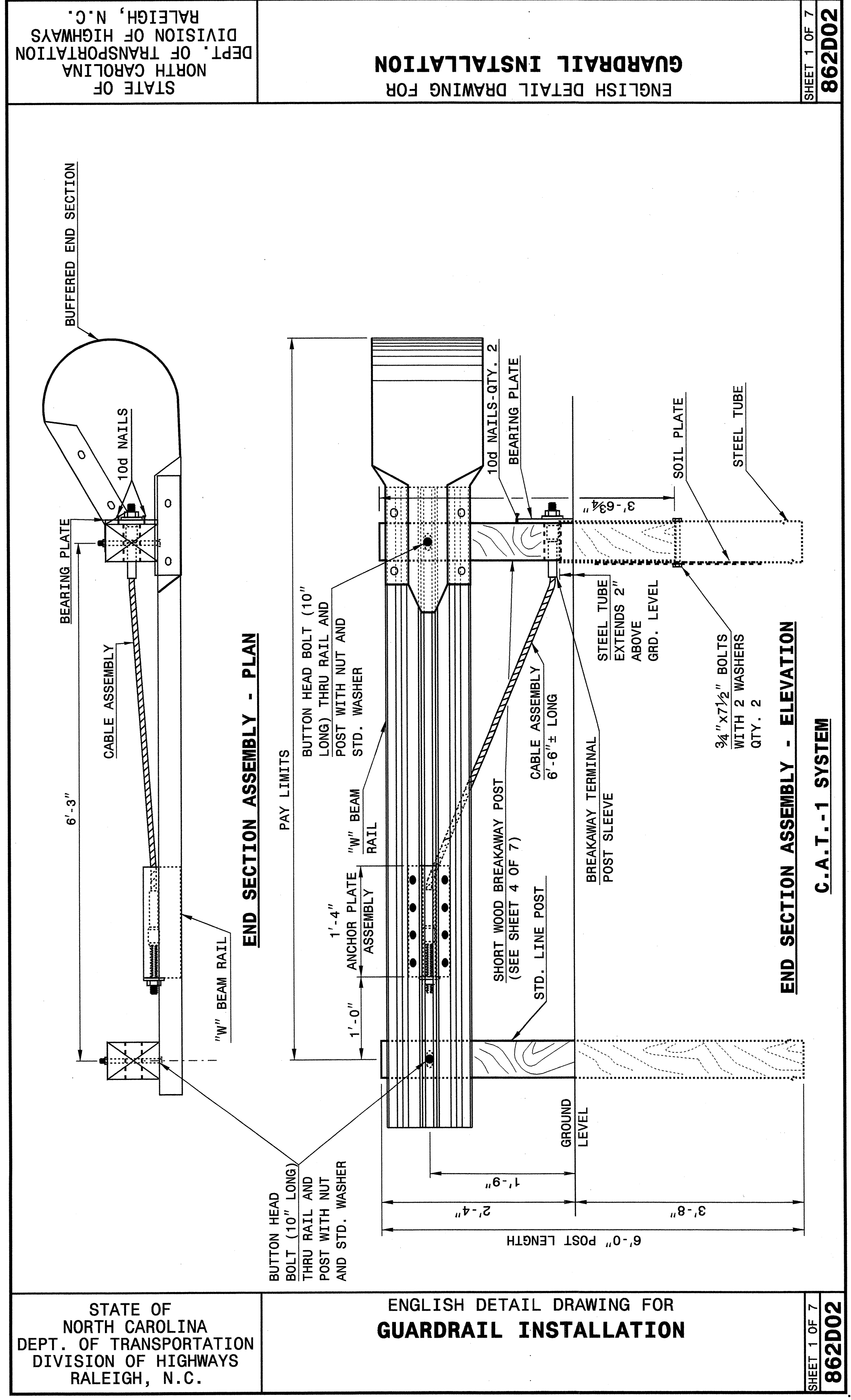

STATE OF NORTH CAROLINA  
DEPT. OF TRANSPORTATION  
DIVISION OF HIGHWAYS  
RALEIGH, N.C.

ENGLISH DETAIL DRAWING FOR  
**GUARDRAIL INSTALLATION**

SHEET 1 OF 7  
**862D02**

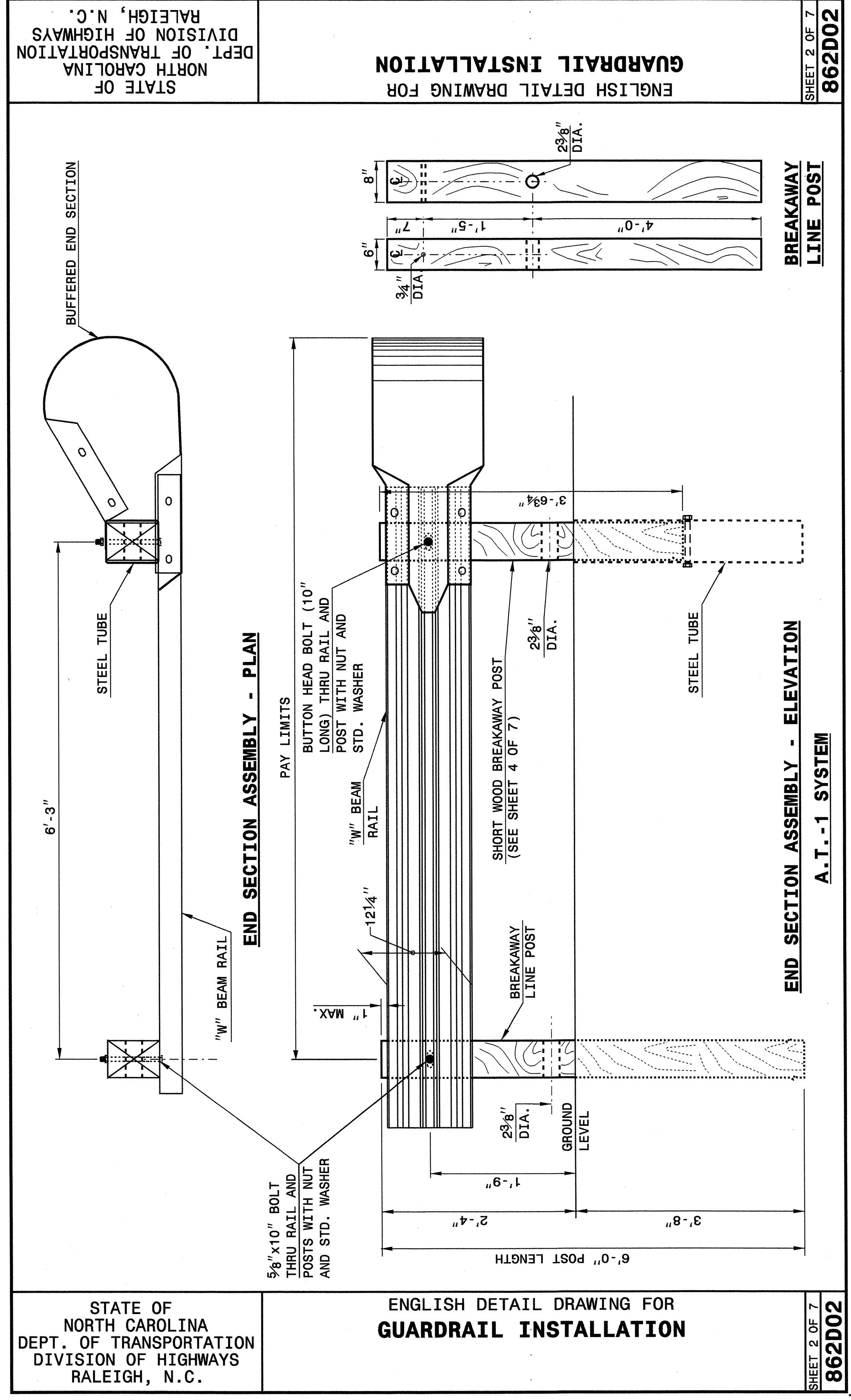

STATE OF NORTH CAROLINA  
DEPT. OF TRANSPORTATION  
DIVISION OF HIGHWAYS  
RALEIGH, N.C.

ENGLISH DETAIL DRAWING FOR  
**GUARDRAIL INSTALLATION**

SHEET 2 OF 7  
**862D02**

**DESIGN SERVICES UNIT  
STANDARDS AND SPECIAL DESIGN**  
Office 919-250-4128 FAX 919-250-4119

**SEE PLATE FOR TITLE**

ORIGINAL BY: 2002 STD.862.02 DATE: \_\_\_\_\_  
 MODIFIED BY: E.E. WARD DATE: 02-09-03  
 CHECKED BY: *Joel S. Howerton* DATE: 4-29-04  
 FILE SPEC.: \\sfs\stds\02\stdetail\english\86202\862d02.dgn

