

| INDEX (BRIDGES) | | | |
|-----------------|----------------|--|------------------|
| | STATION | DESCRIPTION | SHEET NUMBER |
| A | 18+64.065 -L- | BRIDGE ON US 74 BUS. OVER US-74 BYPASS | S-1 THRU S-38 |
| B | 68+75.743 -L- | BRIDGE ON SR 1166 OVER US-74 BYPASS | S-39 THRU S-68 |
| C | 113+73.429 -L- | BRIDGE ON US-74 BYPASS (LEFT LANE) OVER NC 710 | S-69 THRU S-94 |
| D | 113+73.429 -L- | BRIDGE ON US-74 BYPASS (RT. LANE) OVER NC 710 | S-95 THRU S-120 |
| E | 138+30.800 -L- | BRIDGE ON US-74 BYPASS (LEFT LANE) OVER CSX R.R. | S-121 THRU S-146 |
| F | 138+30.800 -L- | BRIDGE ON US-74 BYPASS (RT. LANE) OVER CSX R.R. | S-147 THRU S-172 |

R-513 A

R-513 BA

| INDEX (CULVERTS) | | | |
|------------------|-----------------|-------------------------|----------------|
| | STATION | DESCRIPTION | SHEET NUMBER |
| G | 12+42.500 -Y2- | DOUBLE 2.4m X 2.1m RCBC | C-1 THRU C-4 |
| H | 14+19.671 -RPB- | DOUBLE 2.4m x 1.8m RCBC | C-5 THRU C-9 |
| I | 14+40.000 -Y1- | DOUBLE 2.4m x 1.8m RCBC | C-10 THRU C-14 |
| J | 12+86.500 -SR1- | DOUBLE 2.4m x 1.8m RCBC | C-15 THRU C-19 |
| K | 120+86.500 -L- | TRIPLE 3.0m x 2.7m RCBC | C-20 THRU C-24 |

R-513 A

R-513 BA

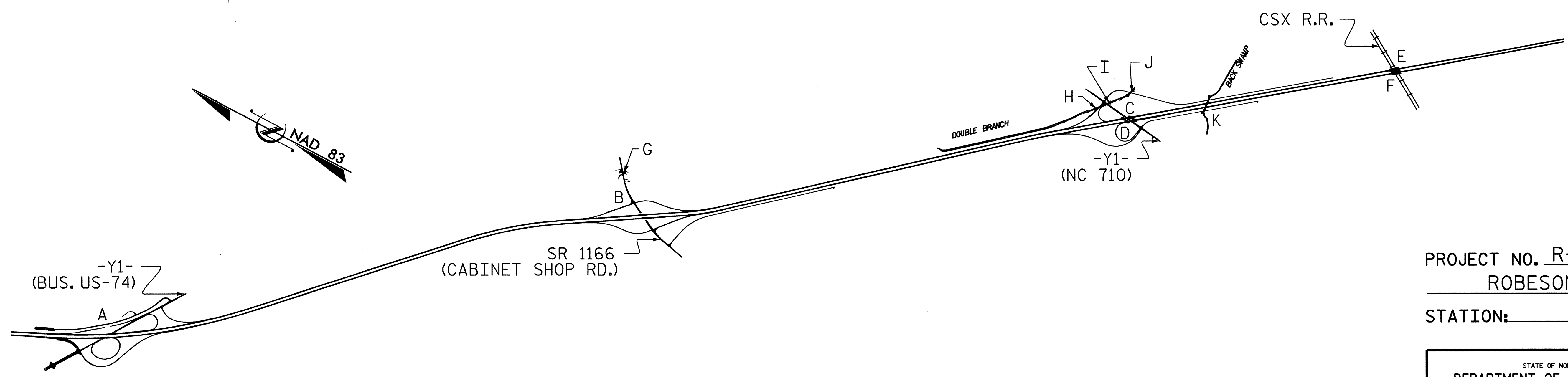

PROJECT NO. R-513A & BA
ROBESON COUNTY
 STATION: _____

STATE OF NORTH CAROLINA
 DEPARTMENT OF TRANSPORTATION
 RALEIGH

INDEX OF BRIDGES
 & CULVERTS

| REVISIONS | | | | | | SHEET NO. |
|-----------|-----|-------|-----|-----|-------|--------------|
| NO. | BY: | DATE: | NO. | BY: | DATE: | TOTAL SHEETS |
| 1 | | | 3 | | | |
| 2 | | | 4 | | | |