

**NOTES**

STIRRUPS IN CAP MAY BE SHIFTED AS NECESSARY TO CLEAR ANCHOR BOLTS.

FOR EPOXY PROTECTIVE COATING, SEE SPECIAL PROVISIONS.

PIPE DRAINS MAY BE SHIFTED SLIGHTLY AS NECESSARY TO CLEAR REINFORCING STEEL AND ANCHOR BOLTS.

BACKWALL SHALL BE PLACED BEFORE APPLYING THE EPOXY PROTECTIVE COATING.

THE TOP SURFACE AREAS OF THE END BENT CAPS SHALL BE CURED IN ACCORDANCE WITH THE STANDARD SPECIFICATIONS EXCEPT THAT THE MEMBRANE CURING COMPOUND METHOD SHALL NOT BE USED.

THE TOP SURFACE OF THE CAP EXCEPT THE BRIDGE SEAT BUILDUPS SHALL BE SLOPED TRANSVERSELY FROM THE FILL FACE TO THE BACK FACE AT THE RATE OF 2%.

THE CONTRACTOR SHALL PROVIDE FOR INSTALLATION OF THE 102mm DIAMETER DRAIN PIPE THROUGH THE WING WALL AS REQUIRED FOR REINFORCED BRIDGE APPROACH FILLS, SEE THE ROADWAY PLANS. REINFORCING STEEL IN THE WING WALL MAY BE SHIFTED AS NECESSARY TO CLEAR THE DRAIN PIPE.

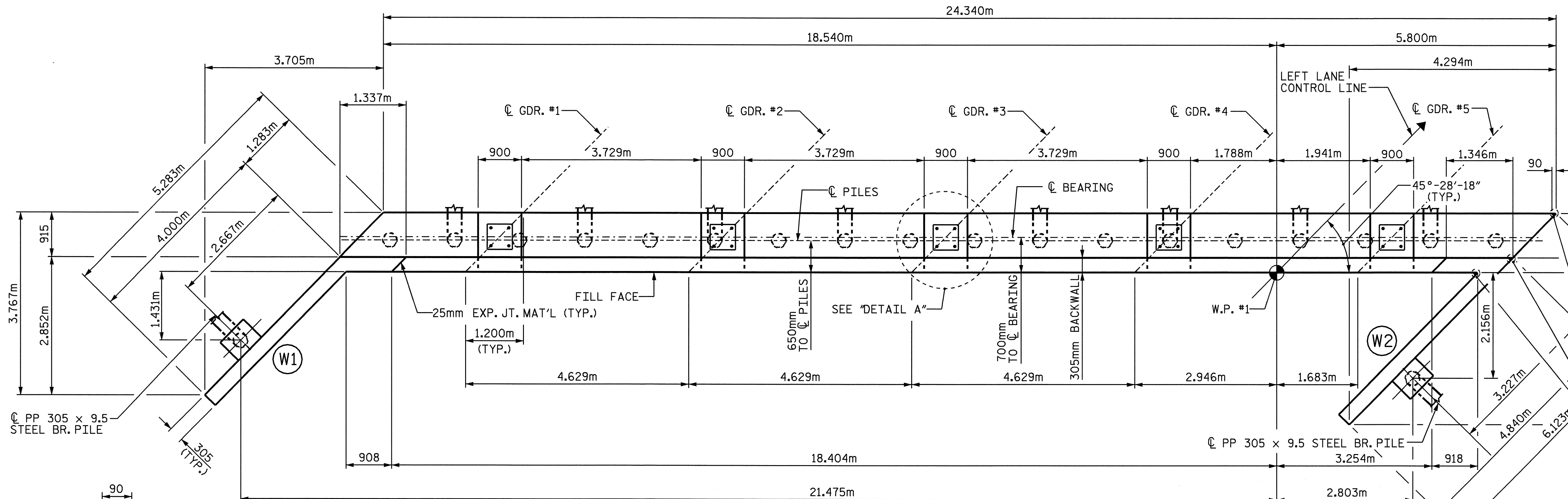

**PLAN**

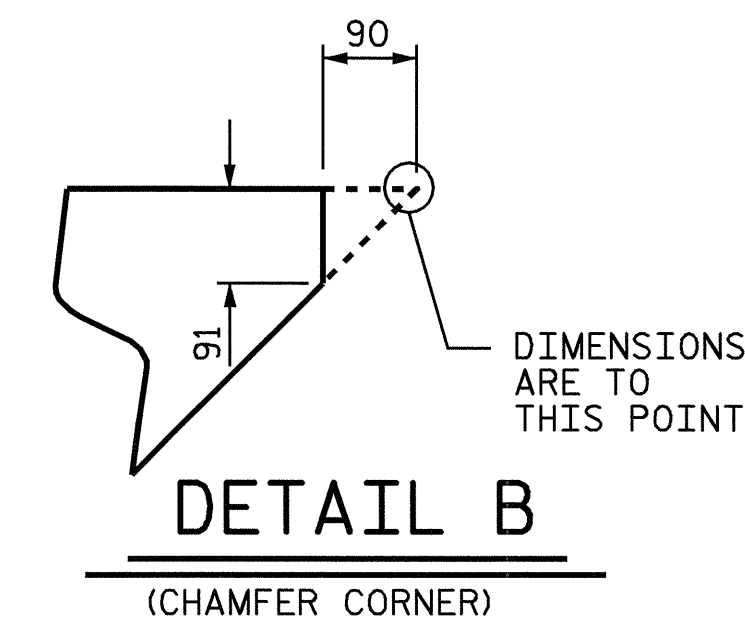

**DETAIL B**  
(CHAMFER CORNER)

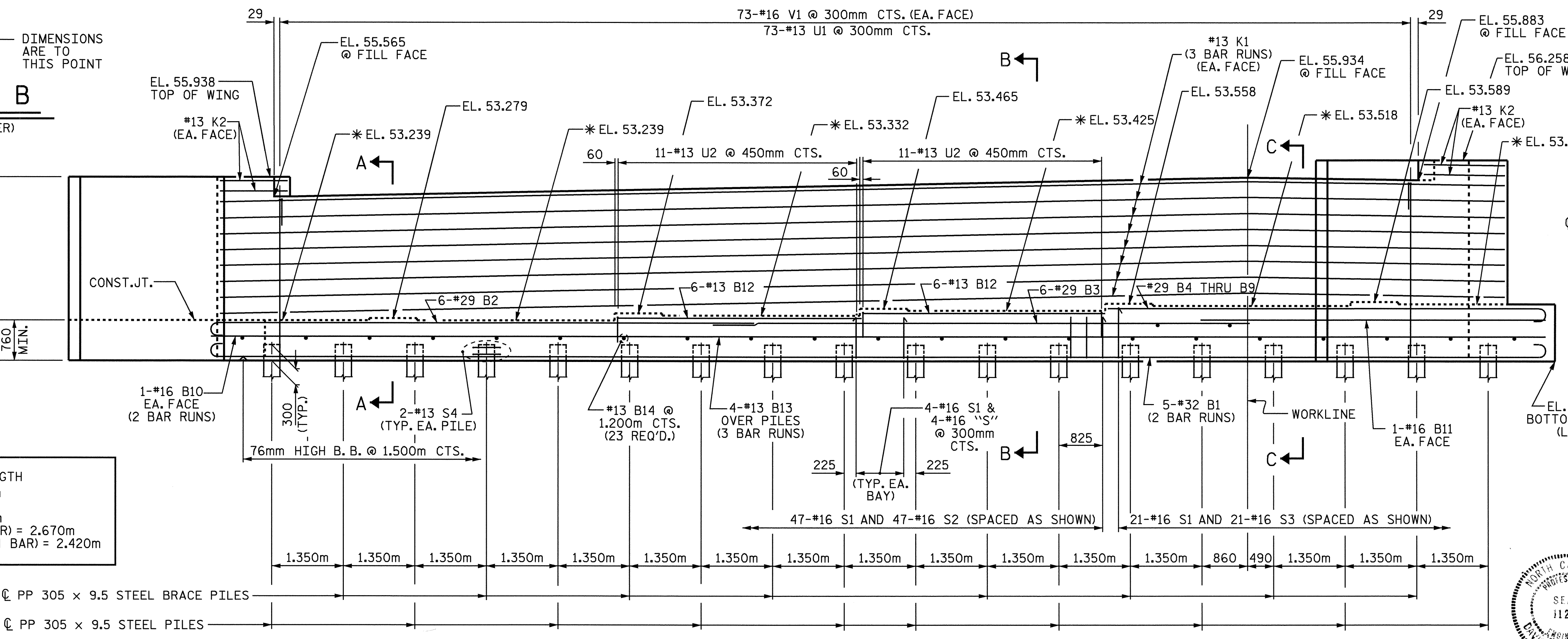

**ELEVATION**

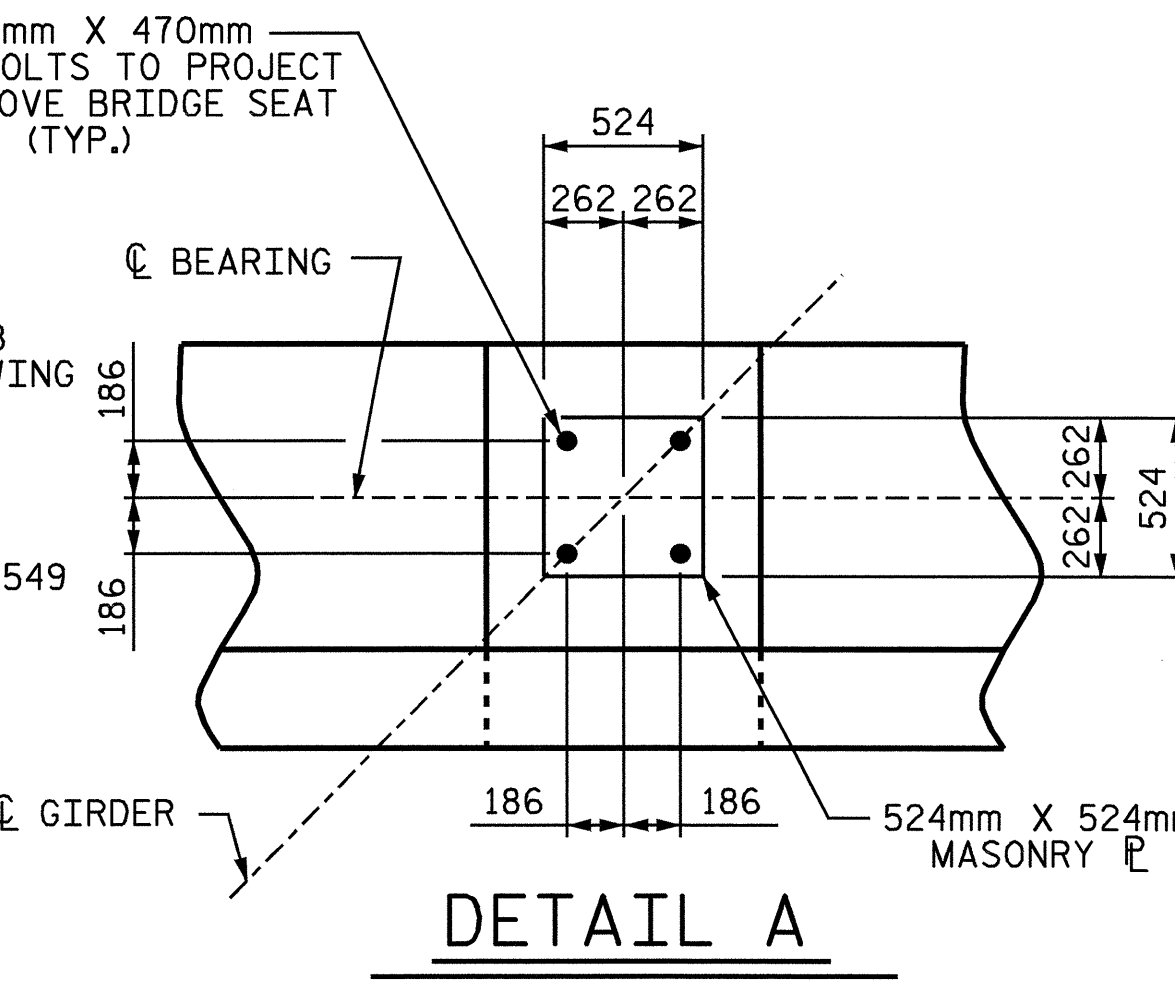

**DETAIL A**

**SPLICE LENGTH**

- #13 "B" = 740mm
- #13 "K" = 740mm
- #16 "B" = 920mm
- #29 "B" (TOP BAR) = 2.670m
- #32 "B" (BOTTOM BAR) = 2.420m

\* FOR LOCATION OF ELEVATION BETWEEN BRIDGE SEAT BUILDUPS, SEE SECTIONS A-A, B-B & C-C SHEET 3 OF 3

PROJECT NO. R-513BA  
ROBESON COUNTY  
STATION: 113+73.429 -L-

SHEET 1 OF 3

STATE OF NORTH CAROLINA  
DEPARTMENT OF TRANSPORTATION  
RALEIGH

SUBSTRUCTURE  
END BENT 1  
(LEFT LANE)

REVISIONS						SHEET NO.	
NO.	BY:	DATE:	NO.	BY:	DATE:	TOTAL SHEETS	
1			3			5-83	
2			4			172	

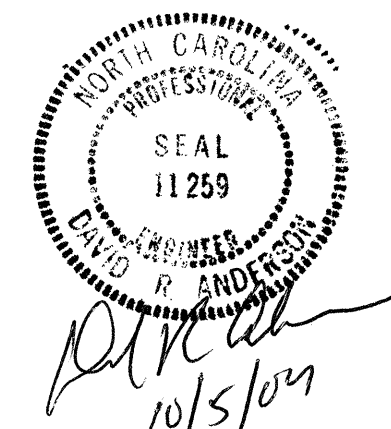

DRAWN BY : S. M. RASHIDI DATE : 01/06/03  
CHECKED BY : M. A. ALLEN DATE : 03-04

04-OCT-2004 10:03  
\\Squagm\0513ba\str\srashidi\Microstation\R-0513BA.sd.E\*.0L.dgn  
srashidi

STR. #1