

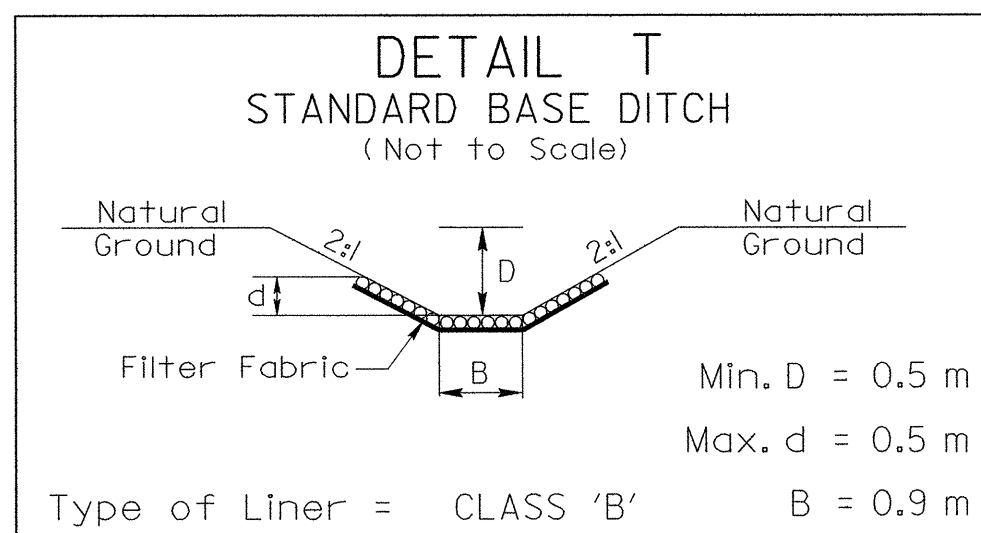

CONST. REV.

R/W REV.

PROJECT REFERENCE NO. R-2206B		SHEET NO. 2-C	
R/W SHEET NO.			
ROADWAY DESIGN ENGINEER		HYDRAULICS ENGINEER	
WILBUR SMITH ASSOCIATES P.O. BOX 2478 RALEIGH, N. C. 27602-2478		TRANSITE CONSULTING 1300 PARKWOOD DRIVE, SUITE 4-10 RALEIGH, N. C. 27609	



USE ON:
-L- 125+65 TO 126+00 RT.
-L- 126+15 LT. EST. DDE = 79 CM

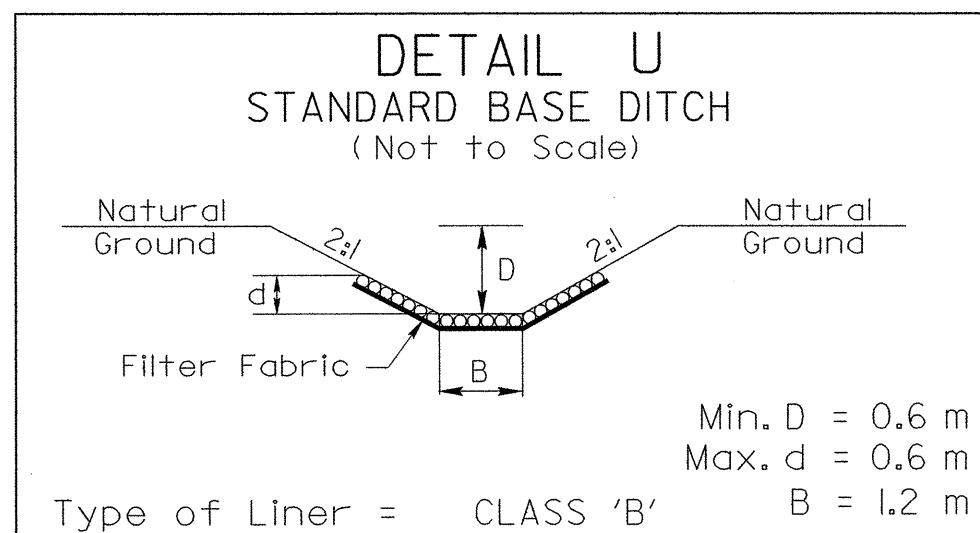

USE ON:
-L- 178+48 RT. EST. DDE = 20 CM

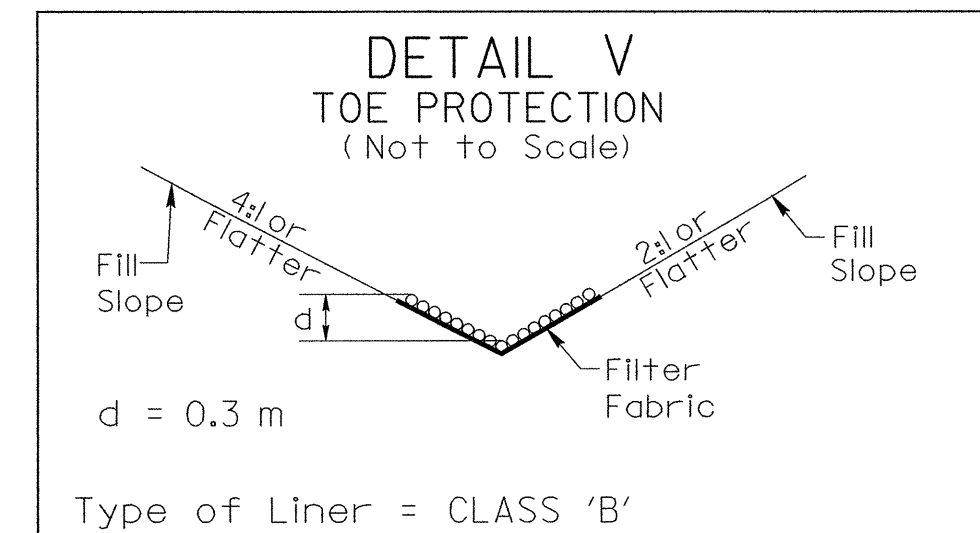

USE ON:
-Y12- 15+86.503 TO 16+46.503 RT.

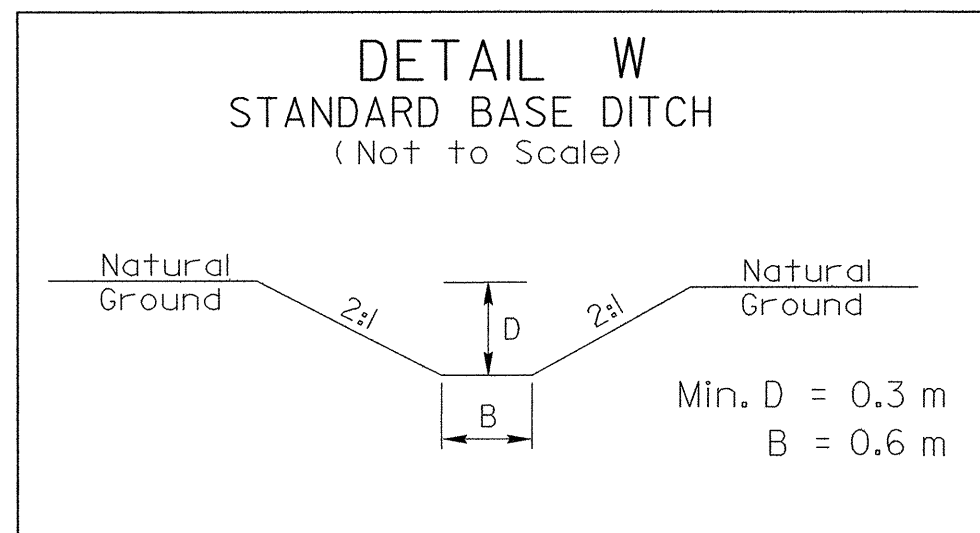

USE ON:
-L- 119+20 TO 119+40 LT. EST. DDE = 24 CM

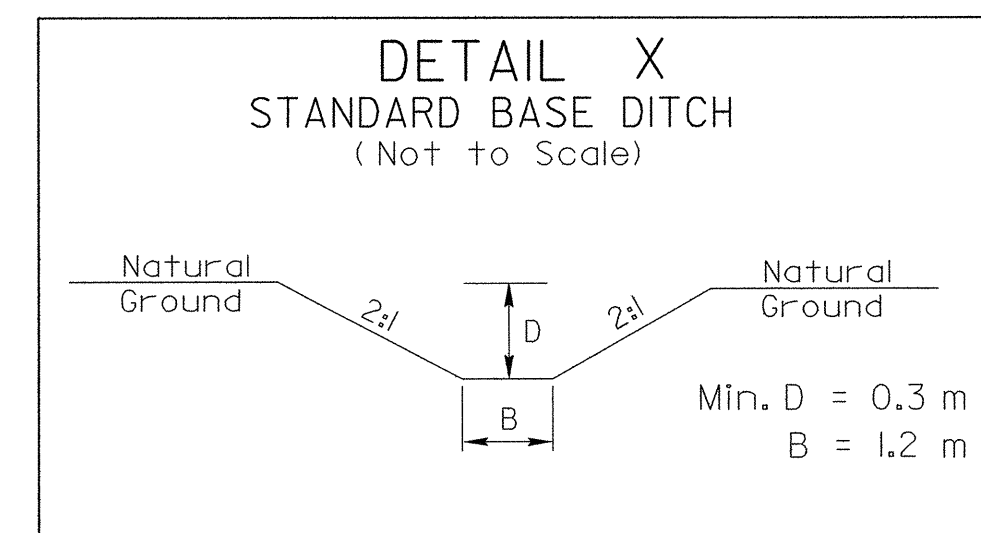

USE ON:
-L- 177+70 RT.

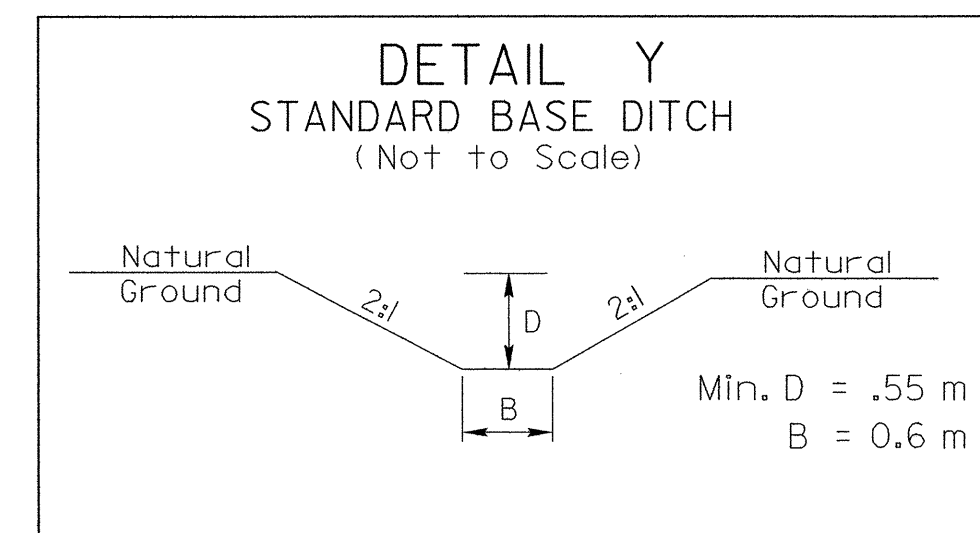

USE ON:
-L- 132+97 TO 133+12 LT. EST. DDE = 68 CM

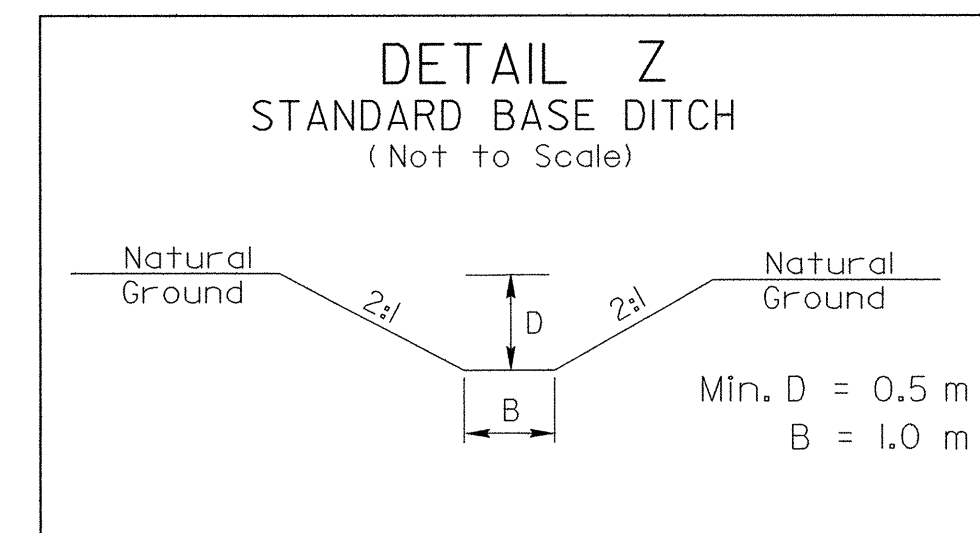

USE ON:
-L- 169+90 LT. EST. DDE = 8 CM
-L- 170+00 RT. EST. DDE = 8 CM

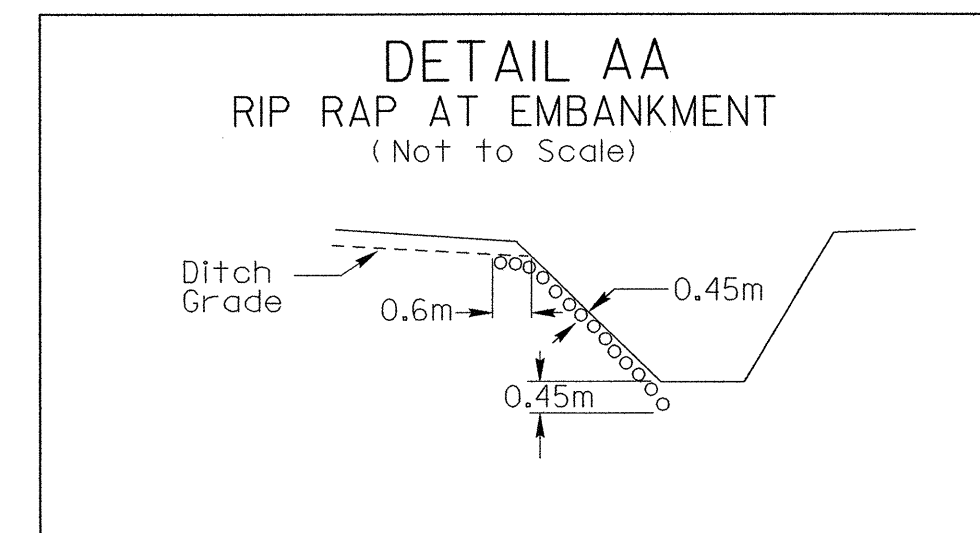

USE ON:
-L- 114+69 TO 114+76 LT. EST. 10 m TONS CLASS '1' RIP RAP
-L- 172+58 LT. EST. 6 m TONS CLASS '1' RIP RAP
-L- 173+30 RT. EST. 12 m TONS CLASS '1' RIP RAP
-L- 178+60 RT. EST. 16 m TONS CLASS '1' RIP RAP
-Y9- 18+43 RT. EST. 15 m TONS CLASS '1' RIP RAP
-Y9- 18+55 LT. EST. 4 m TONS CLASS '1' RIP RAP

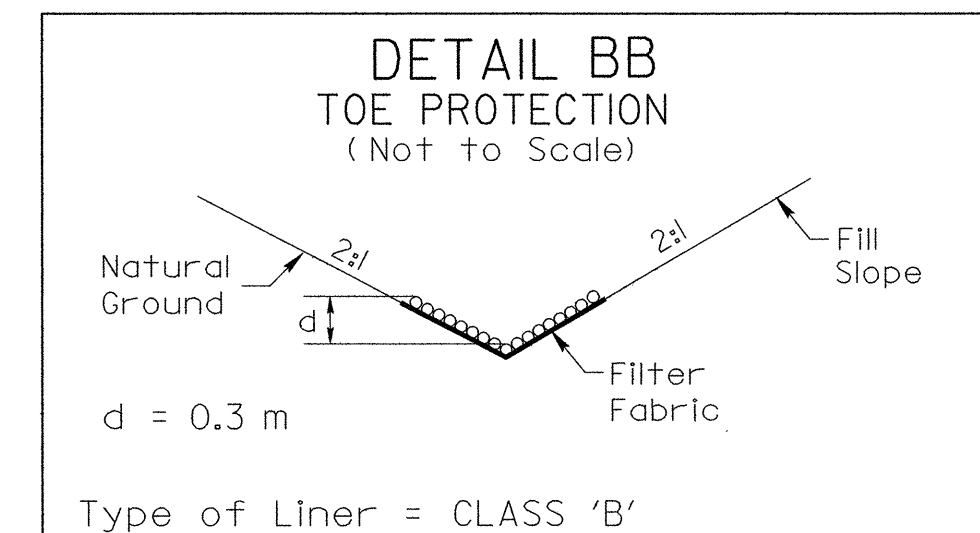

USE ON:
-L- 131+64 TO 132+20 LT. -L- 169+20 TO 169+89 LT.
-L- 134+83 TO 134+94 LT. -L- 171+00 TO 171+80 RT.
-L- 145+85 TO 146+10 LT. -L- 172+95 TO 173+80 LT.
-L- 150+40 TO 151+52 LT.

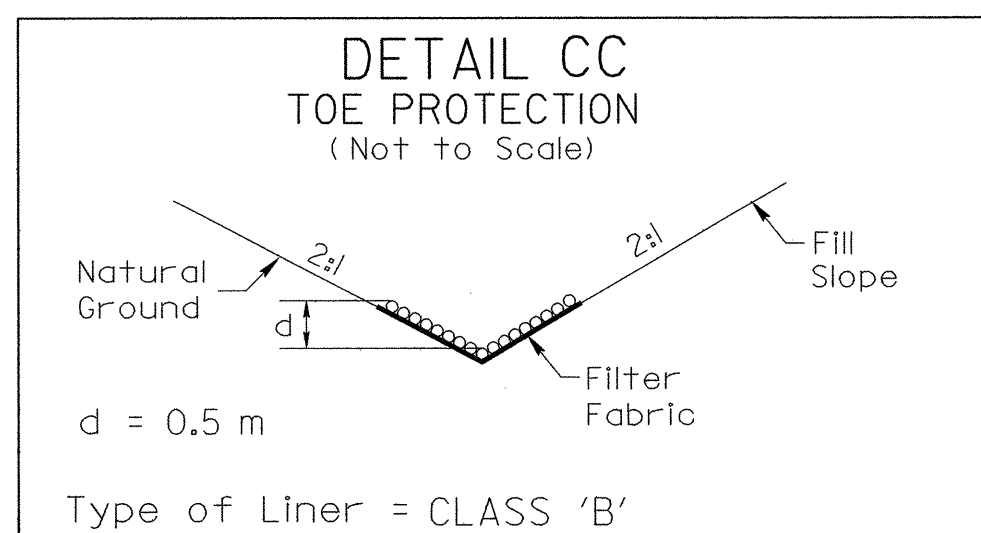

USE ON:
-Y9- 17+35 TO 17+67 LT.

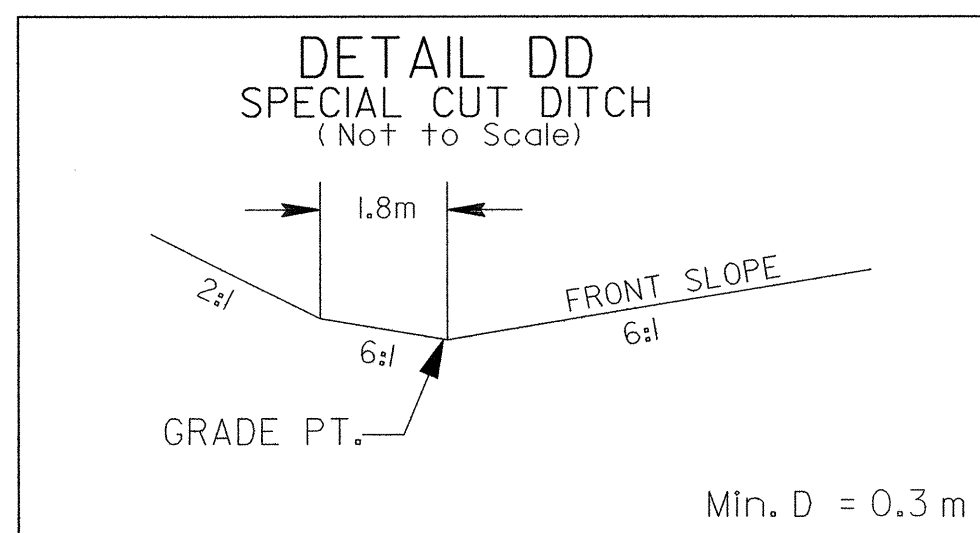

USE ON:
-L- 117+20 TO 117+60 RT.
-L- 120+60 TO 121+00 RT.

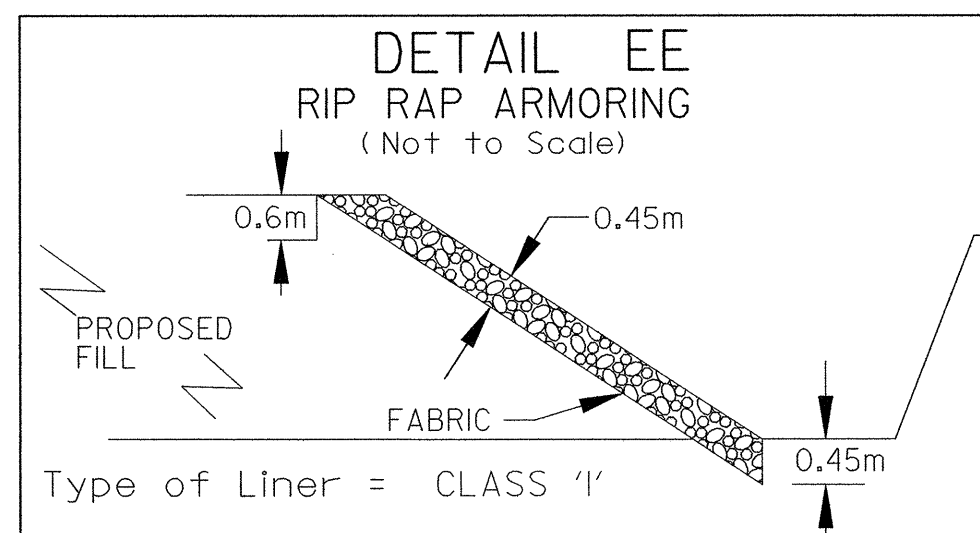

USE ON:
-L- 133+12 LT. EST. 10 TONS

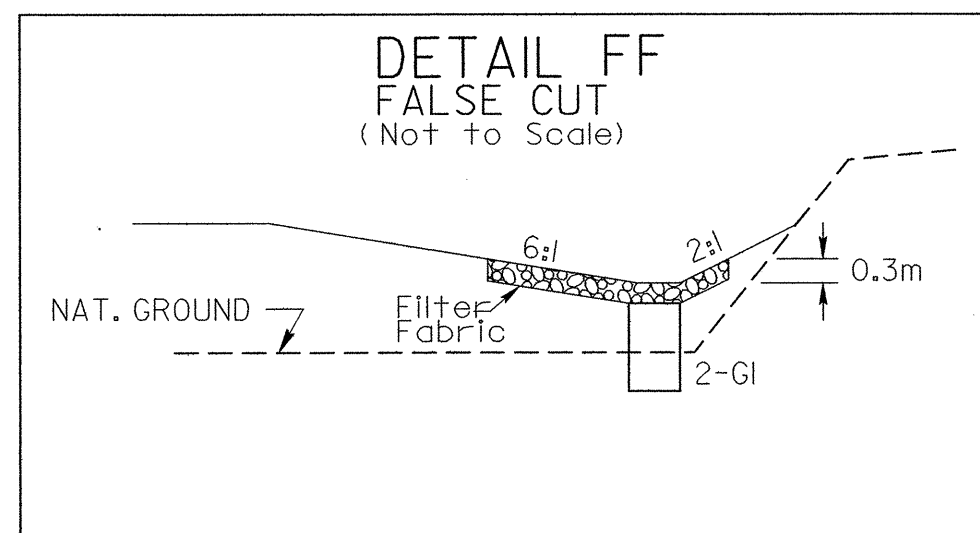

USE ON:
-L- 135+60 TO 135+80 RT.

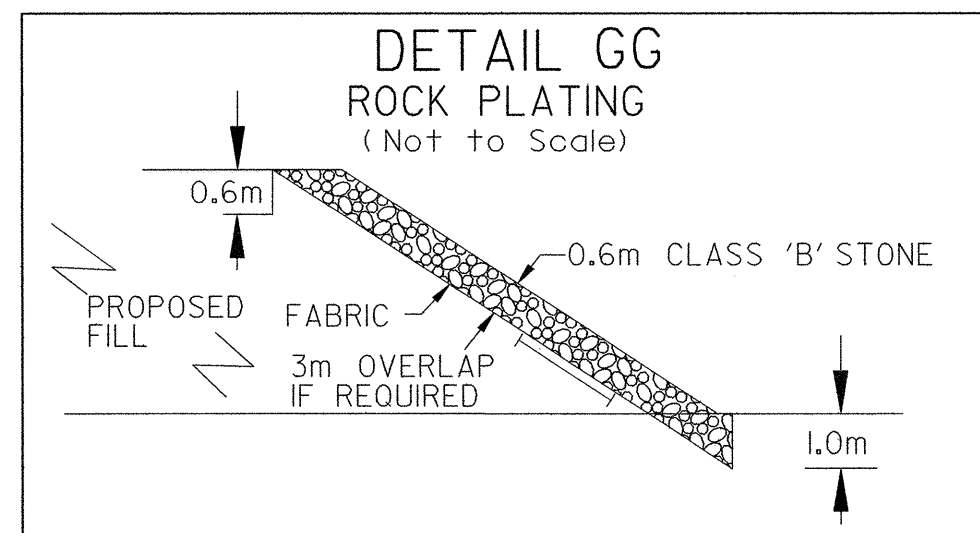

USE ON:
-L- 121+80 TO 122+50 LT.

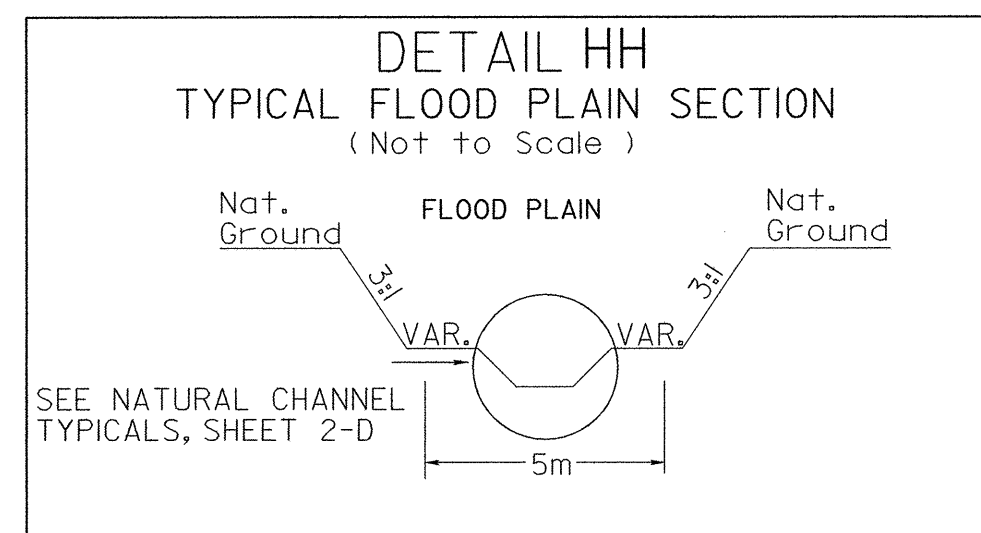

USE ON:
-L- 157+95 TO 158+54 RT. EST. DDE = 770 CM (RT)
-L- 159+36 TO 160+35 LT. EST. DDE = 1420 CM (LT.)

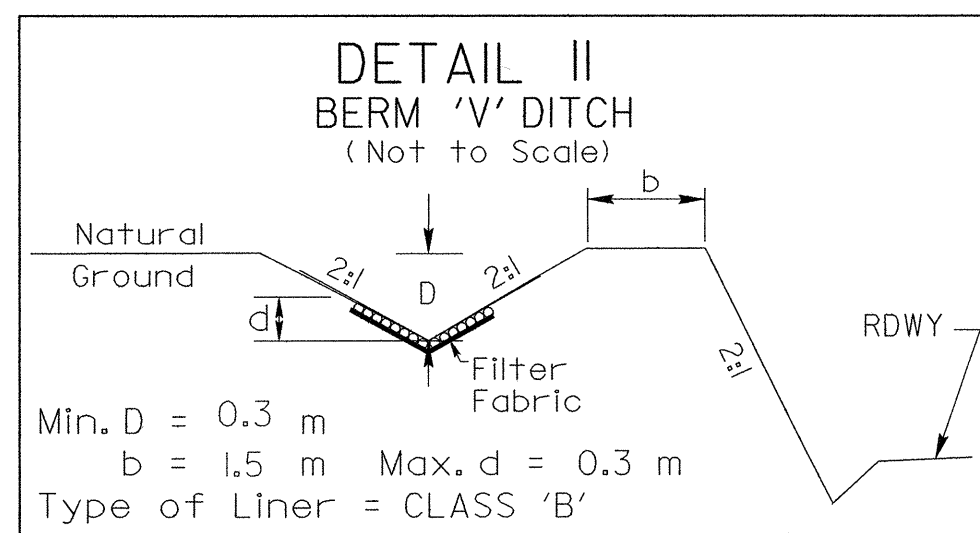

USE ON:
-L- 152+95 TO 153+03 LT. EST. DDE = 29 CM

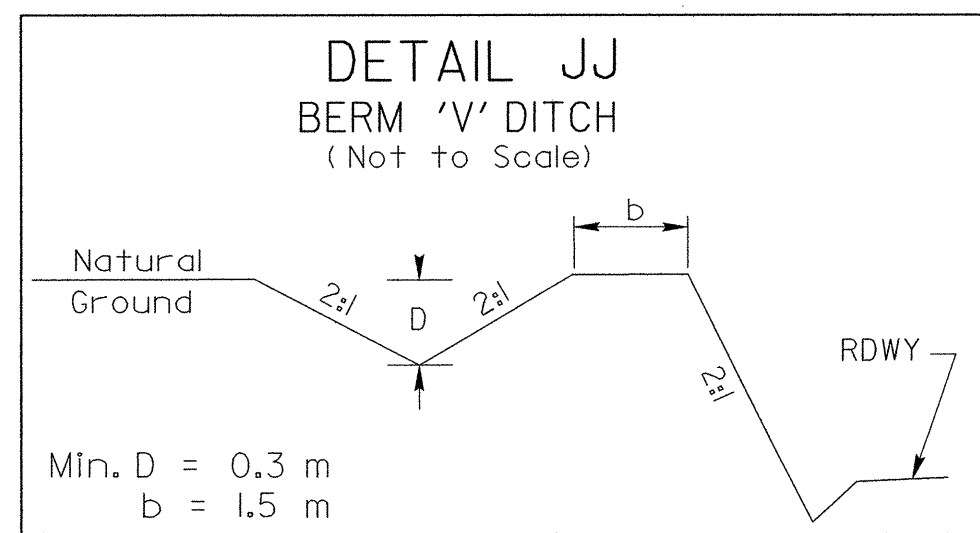

USE ON:
-L- 152+74 TO 152+95 LT. EST. DDE = 144 CM

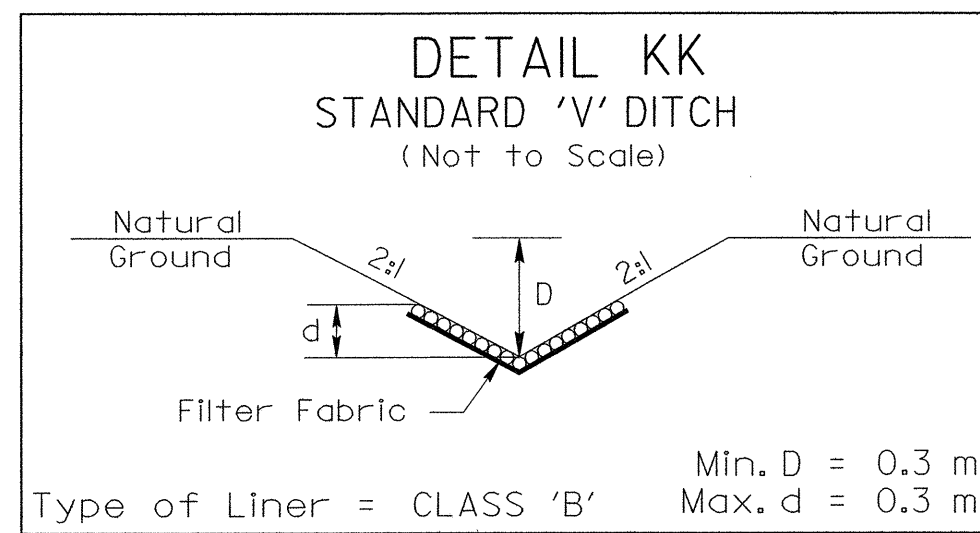

USE ON:
-L- 109+34 TO 109+40 LT. EST. DDE = 14 CM

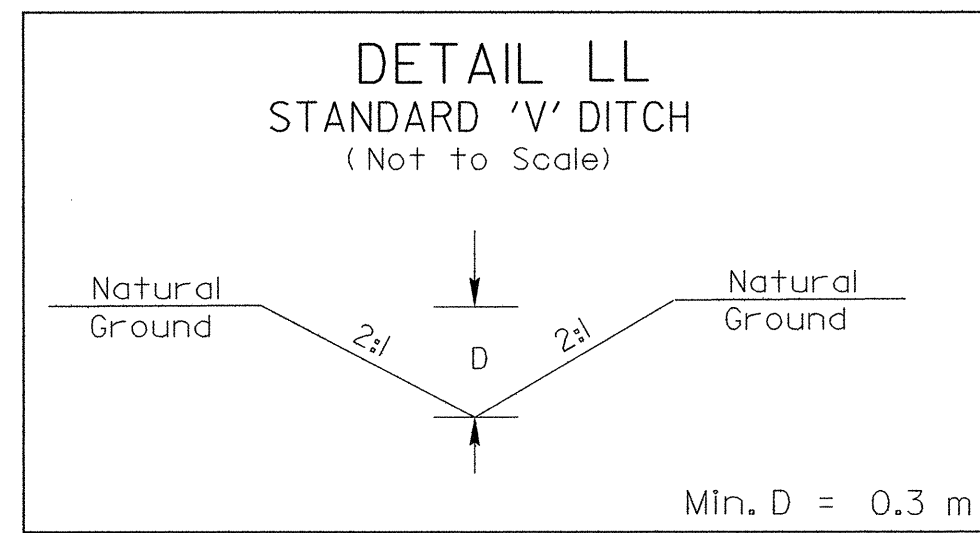

USE ON:
-L- 109+19 TO 109+30 RT. EST. DDE = 5 CM
-L- 175+93 LT. EST. DDE = 3 CM

DATE: 8/27/04
TIME: 4:21:52 PM
r:\mcd\1-2206b\sheet02.csh